

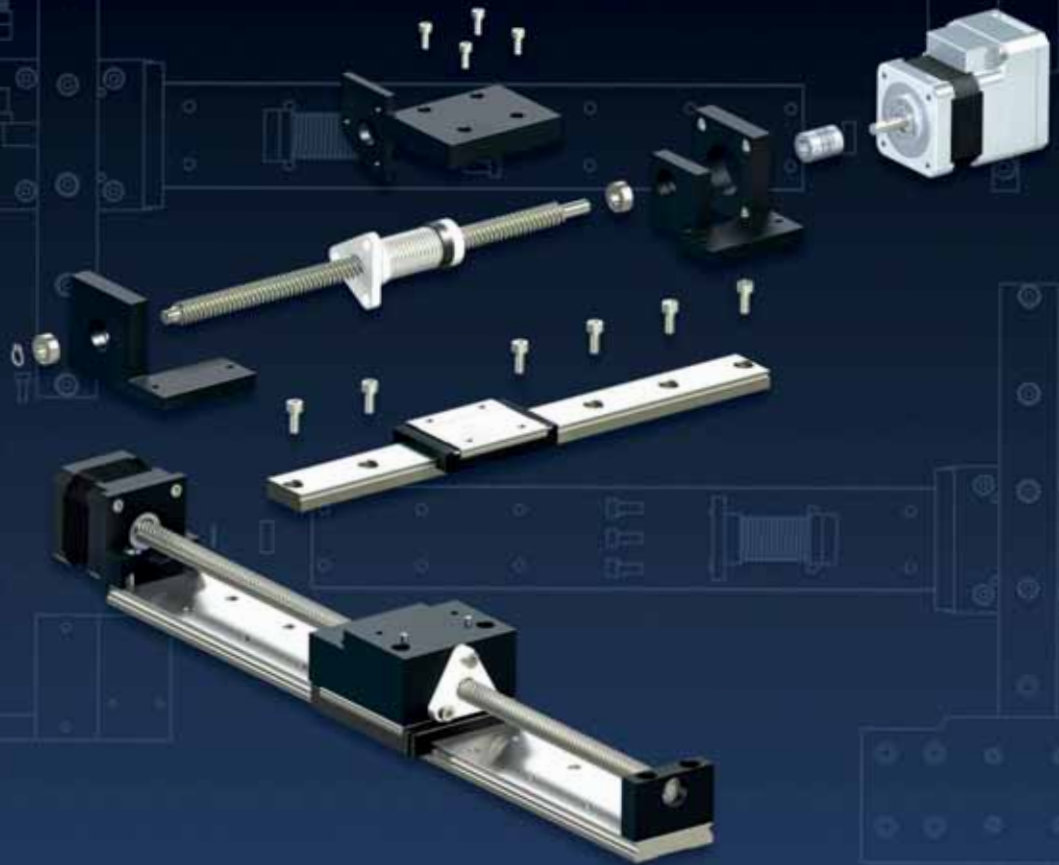

# Reliance<sup>®</sup>

Precision Limited



**Precise Motion Control Solutions**

|   |   |           |
|---|---|-----------|
|   | <i>Introduction to Reliance</i>                       | <i>i</i>  |
|   | <i>Systems Overview</i>                               | <i>1</i>  |
|    | <b>Intelligent Motors and Motorised Actuators</b>     | <b>2</b>  |
|    | <b>Planetary and Right Angle Gearboxes</b>            | <b>3</b>  |
|    | <b>Brass, Ground and Precision Spur Gears</b>         | <b>4</b>  |
|    | <b>Worms and Wheels, Bevels and Internal Gears</b>    | <b>5</b>  |
|    | <b>Round and Rectangular Racks and Pinions</b>        | <b>6</b>  |
|    | <b>Leadscrews and Leadscrew Assemblies</b>            | <b>7</b>  |
|    | <b>Flexible Shaft Couplings, Clutches and Collars</b> | <b>8</b>  |
|    | <b>Linear Guides and Slides</b>                       | <b>9</b>  |
|   | <b>Belts and Pulleys</b>                              | <b>10</b> |
|  | <b>Gear Clamps and Accessories</b>                    | <b>11</b> |
|  | <b>Bearings and Spacers</b>                           | <b>12</b> |
|  | <b>Machine Screws, Dowel Pins and Hardware</b>        | <b>13</b> |
|   | <i>Technical Information</i>                          | <i>14</i> |
|   | <i>Appendices and Index</i>                           | <i>15</i> |



---

## Reliance in the United Kingdom

Rowley Mills, Penistone Road  
Lepton, Huddersfield  
HD8 0LE,  
England.

Sales and technical enquiries:

 +44 (0) 1484 601002  
 [sales@reliance.co.uk](mailto:sales@reliance.co.uk)





---

## Reliance in the Netherlands

Florijnstraat 20  
4879 AH Etten-Leur,  
The Netherlands.

Sales and technical enquiries:

 +31 (0) 76 5040790  
 [sales@reliance.co.uk](mailto:sales@reliance.co.uk)



---

## Reliance World-wide

For international sales representatives,  
please see appendices page A-6



---

## Reliance On-line

[www.reliance.co.uk](http://www.reliance.co.uk)  
[www.relianceprecision.fr](http://www.relianceprecision.fr)  
[www.relianceprecision.nl](http://www.relianceprecision.nl)  
[www.relianceprecision.de](http://www.relianceprecision.de)

---

Component data and information included in this RG36 catalogue supersedes that stated in all previous publications. Reliance Precision Limited is committed where possible to supply products listed in previous catalogues; please contact us if the component or part number is not listed in RG36.

Reliance would like to acknowledge the support of its customers and suppliers who have kindly given permission to show images of their equipment.

Copyright © 2013 Reliance Precision Limited.

The Reliance shield and Reliance are registered trademarks ® of Reliance Precision Limited.



Rowley Mills, Huddersfield  
1980 to present





Union Street, Huddersfield,  
right 1920 to 1955



St Helen's Gate, Huddersfield,  
below 1955 to 1996



Bandon, Ireland  
1969 - present

# Introduction to Reliance





## Reliance - a specialist engineering company

Welcome to Reliance. We are a specialist engineering company, unique in our offering of catalogue products and fully bespoke solutions.

Our product catalogue provides a one-stop-shop for the design engineer – from basic essentials, such as captive screws, to complete sub-assemblies for rotary and linear motion. We offer a carefully selected mix of in-house designed and manufactured products together with products from leading global manufacturers, all of which can be modified to suit individual requirements. We are able to provide design support at the early stages of new product development to create complete prototyping solutions and cost-effective integrated assemblies for full production requirements.

As well as providing catalogue products we have extensive design, development, manufacturing, assembly and test facilities in the UK and Ireland, recently enhanced by a £6million investment programme. From here we offer turnkey technical services for customers requiring bespoke components, assemblies, and systems, not only helping bring new products to market, but also resolving technical problems and extending the life of established products.

Our aim is to provide choice and flexibility for our customers. From standard ex-stock components to custom-designed and manufactured sub-systems or even complete instruments.

Wherever your starting point is with Reliance you should expect technical excellence, high quality solutions and our total commitment to the success of your project.



Managing Director



**Standard Components**



**Modified Components**



**Integrated Solutions**



**Bespoke Assemblies**



Satellite Antenna Pointing Mechanism gear,  
in production for SSTL, and now working in orbit



## Reliance - established in diverse, global markets

We are an accredited supplier to global OEMs and product developers, covering a wide variety of markets and applications.

In Switzerland our tubular round racks provide a space-saving solution for laboratory automation, locating fluid tubes and fibre optic cables inside the rack to give a more compact instrument. In the UK over 5,000 syringe drive mechanisms, using our motors and leadscrews, are in operation in drug dispensing systems. In Asia our precision anti-backlash gears are used in military applications where our innovative, two-piece gear design is ideal for high reliability applications.

Our gears and leadscrews provide motorised actuation for the fingers and thumb of the *bebionic* prosthetic hand. This is a demanding application requiring high efficiency, high gripping force and low noise, to be achieved under tight space and weight constraints in order to give the patient the necessary dexterity, strength and practical wearability.

Our appetite for problem-solving and for providing creative technical solutions, underpinned by a culture of strong teamwork, has led to long-standing relationships built on close technical, operational and commercial co-operation. An enquiry for a standard catalogue gear was the first step in our journey with RSL Steeper, developers of the prosthetic hand. As we began to develop an understanding of the hand at a complete product level a design engineering relationship began which has strengthened year-on-year.



*"We appreciate it's a total team effort to deliver a project, it's a pleasure to work with a company so well co-ordinated who keep us informed all the way through."*

*RSL Steeper*



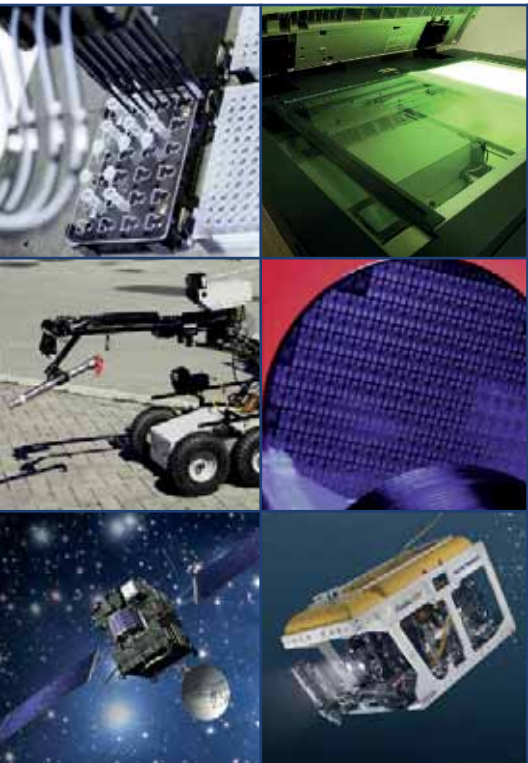

Providing solutions for diverse markets



BS EN ISO 9001



AS9100



BS EN ISO 14001



SC21 Supply Chain



## Reliance – helping you make an informed choice

As an engineering company it is important to us to build a thorough understanding of your wider system design and application in order to recommend the most appropriate product. We consider not only the technical specification, but also the product's suitability to the operational environment and any implications of technical and commercial trade-offs.

Discussion of the technical, operational and commercial requirements are a key part of our product support philosophy. Our aim is to help you make an informed choice about our products before you make a purchasing decision; we want to be confident that what we deliver is going to work for you.

Underpinning our engineering knowledge is a sustained investment in test development facilities, which provide an in-depth understanding of the capabilities of our catalogue products. In discussing their suitability for your application we are able to draw upon our test data and experience of designing and supplying components and assemblies into a diverse range of markets.

As a manufacturer we are able to provide a high level of versatility in our range with extensive modifications available. In our precision gears range we offer, for example, options in materials, gear quality, bore diameters, face widths and an extensive choice of teeth cut to order in short lead-times. Our manufacturing capability also helps provide insight into the fitness-for-purpose of the products, based on an understanding of the manufacturing methods used, quality control, surface finish, accuracies and other key criteria which ultimately impact on the performance of your product.

You can contact us by telephone, email or via our website. Alternatively we are happy to arrange a visit to your premises, which has often proved to be an efficient, effective route to understanding the wider aspects of your design programme and providing the appropriate support.

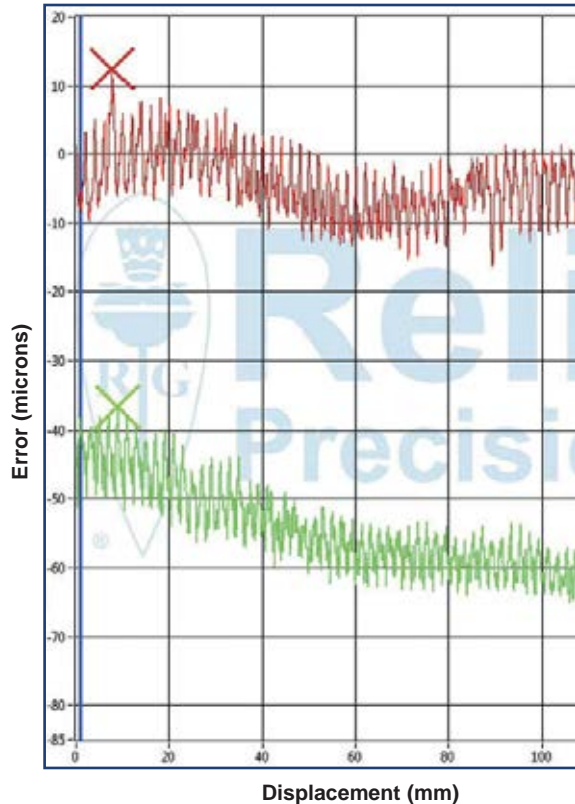



Leadscrew transmission error measurement



Applications Engineering



Test Development



Manufacturing

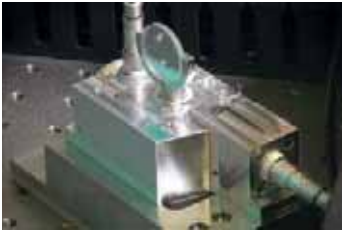

Production Test





# Section Contents

Introduction .....Page 1-2

Rotary Motion .....Page 1-4

Linear Motion .....Page 1-6

Integrated Solutions .....Page 1-8

Bespoke Solutions .....Page 1-12



## Precise motion control solutions

The Reliance catalogue provides a one-stop-shop - from components and assemblies for rotary and linear motion to intelligent control and actuation products. Each product is offered with a refined, considered range of options and associated products, such as circlips and screws, all of which have been engineered to interface correctly.

To help design engineers develop prototypes quickly and effectively, we are able to supply small quantities at stock prices, whilst our manufacturing facilities enable larger quantities to be supplied for full production requirements, available with scheduled delivery, consignment stocking and stock management services.



Our catalogue products can be readily modified to support applications which require a tailored solution. If you are not sure whether we offer the specification you need for any of the products in this catalogue then please contact us and we will endeavour to find a solution.

For design engineers seeking integrated solutions, we are able to combine catalogue products and assemblies to provide cost-effective sub-systems. Should a fully bespoke solution be required, further in-depth design engineering support can also be provided which, together with specialist manufacturing, assembly and test facilities, enables production of a wide range of custom-designed electro-mechanical, opto-mechanical, clean and high-vacuum solutions.

The following pages give an overview of the range of products available in the catalogue, shown in the context of both rotary and linear motion systems. We have also provided case study examples of how the catalogue products, together with engineering, manufacturing, assembly and test support, have been used to provide integrated solutions. Highlights of some of our custom design and manufacturing capabilities are also shown on pages 1-12 to 1-15.



Rotary motion



Linear motion

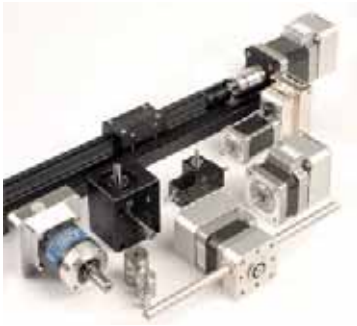

## Intelligent Motion Control

|                                  |           |
|----------------------------------|-----------|
| Reliance Cool Muscle Motors      | Section 2 |
| Reliance Cool Muscle Stage       | Section 2 |
| Rack Actuators                   | Section 2 |
| Linear Rail Actuators            | Section 2 |
| Hybrid Linear Actuators          | Section 2 |
| Motorised Leadscrew Linear Slide | Section 2 |
| Bespoke Motorised Actuators      | Section 2 |
| Planetary Gearboxes              | Section 3 |
| Bevel Gearboxes                  | Section 3 |
| Epicyclic Gearbox Modules        | Section 3 |
| Custom-Designed Gearboxes        | Section 3 |

## Components and Assemblies



|                               |            |
|-------------------------------|------------|
| Anti-Backlash Gears           | Section 4  |
| Spur Gears                    | Section 4  |
| Ground Gears                  | Section 4  |
| Brass Gears                   | Section 4  |
| Custom-Designed Gears         | Section 4  |
| Worms and Wheels              | Section 5  |
| Bevel Gears                   | Section 5  |
| Racks and Pinions             | Section 6  |
| Leadscrews and Nut Assemblies | Section 7  |
| Leadscrew Actuators           | Section 7  |
| Couplings                     | Section 8  |
| Linear Guides and Slides      | Section 9  |
| Belts and Pulleys             | Section 10 |

## Essential Hardware



|                            |            |
|----------------------------|------------|
| Gear Clamps and Collars    | Section 11 |
| Shafts and Accessories     | Section 11 |
| Bearings                   | Section 12 |
| Bearing Pre-loaded Washers | Section 12 |
| Bearing Spacers            | Section 12 |
| Machine Screws             | Section 13 |
| Shoulder Screws            | Section 13 |
| Dowel Pins                 | Section 13 |
| Circlips                   | Section 13 |
| Washers                    | Section 13 |



## Motorised rotary drive system

A motorised rotary system for a medical device, using the Reliance Cool Muscle intelligent servo system together with standard precision gears, which provide very low velocity fluctuation at the final drive, enabling predictable scanning.

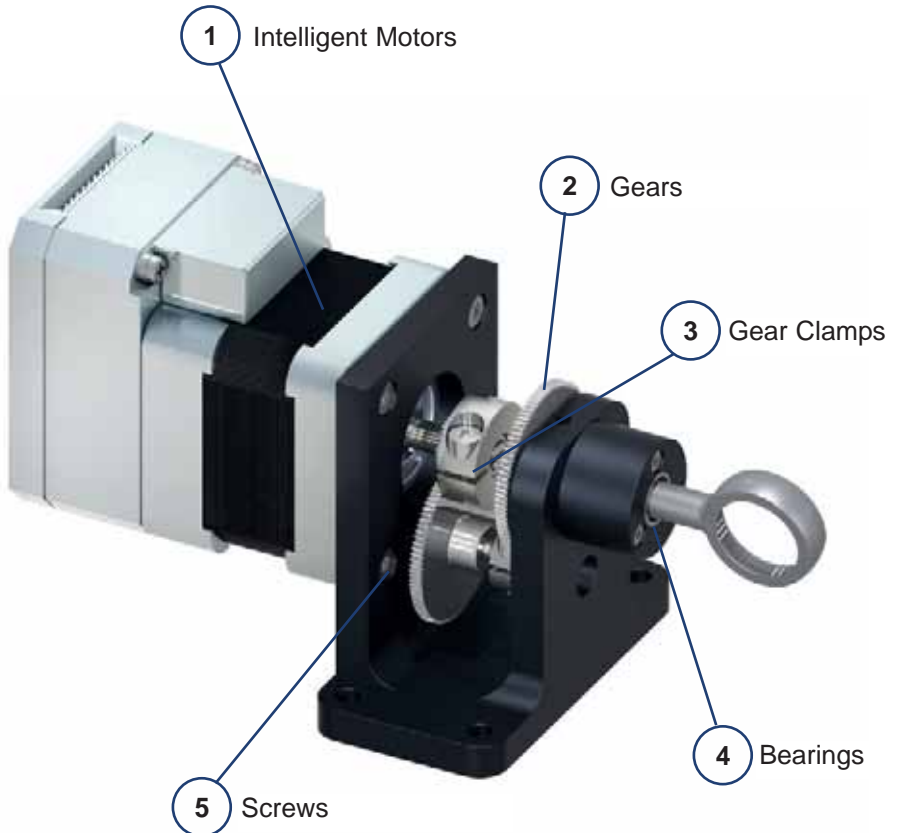





- ① Reliance Cool Muscle  
Intelligent Servo System  
Section 2



- ② Precision Pin Hub and  
Clamp Hub Gears  
Section 4



- ③ Gear Clamps, Shafts  
and Accessories  
Section 11



- ④ Shaft Bearings  
Section 12



- ⑤ Machine Screws, Dowel Pins  
and Circlips  
Section 13



### Motorised linear stage

A motorised linear stage containing high stiffness crossed roller slides, for use in an application requiring vertical motion with a very high moment load.

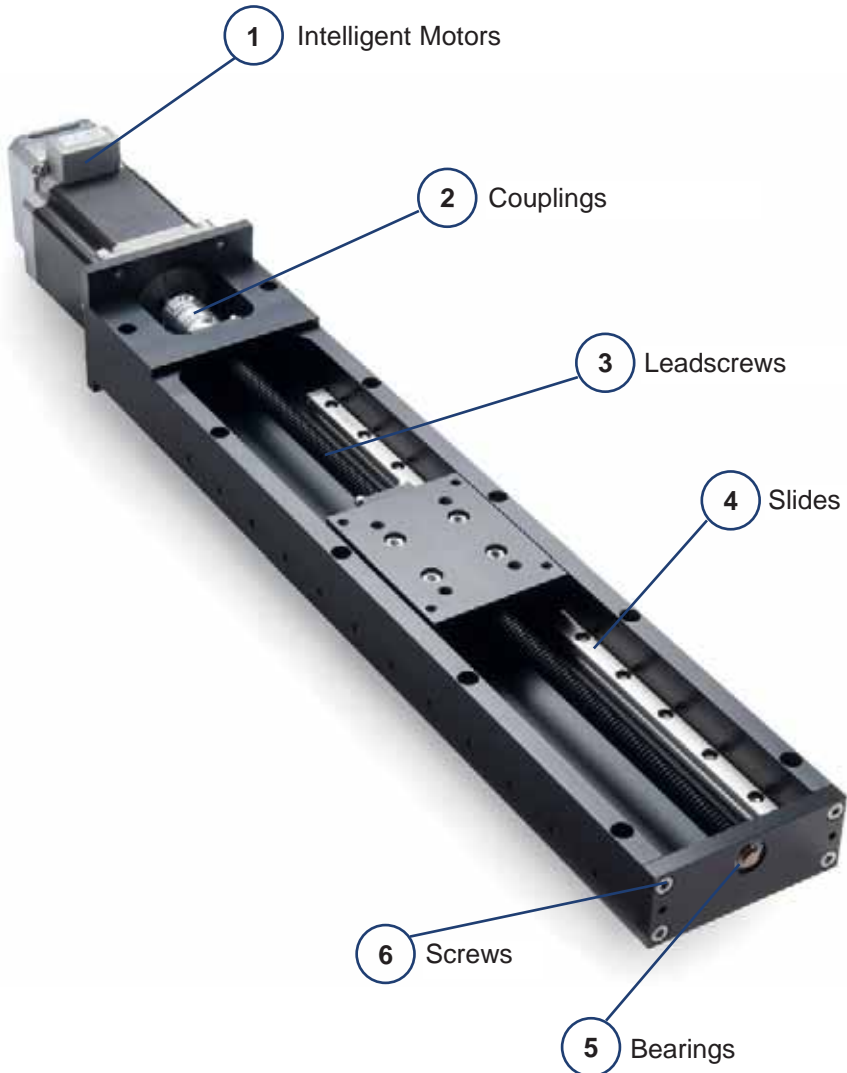



①

Reliance Cool Muscle  
Intelligent Servo System  
Section 2



②

Flexible Shaft Couplings  
Section 8



③

Precision Leadscrews  
Section 7



④

Linear Guides and Slides  
Section 9



⑤

Shaft Bearings  
Section 12



⑥

Machine Screws, Dowel Pins  
and Circlips  
Section 13



## XY positioning stage

A self-contained XY positioning stage utilising extra wide slides to cater for moment loads and internal screw motors for reduced part count, with anti-backlash leadscrews providing accurate positional repeatability.

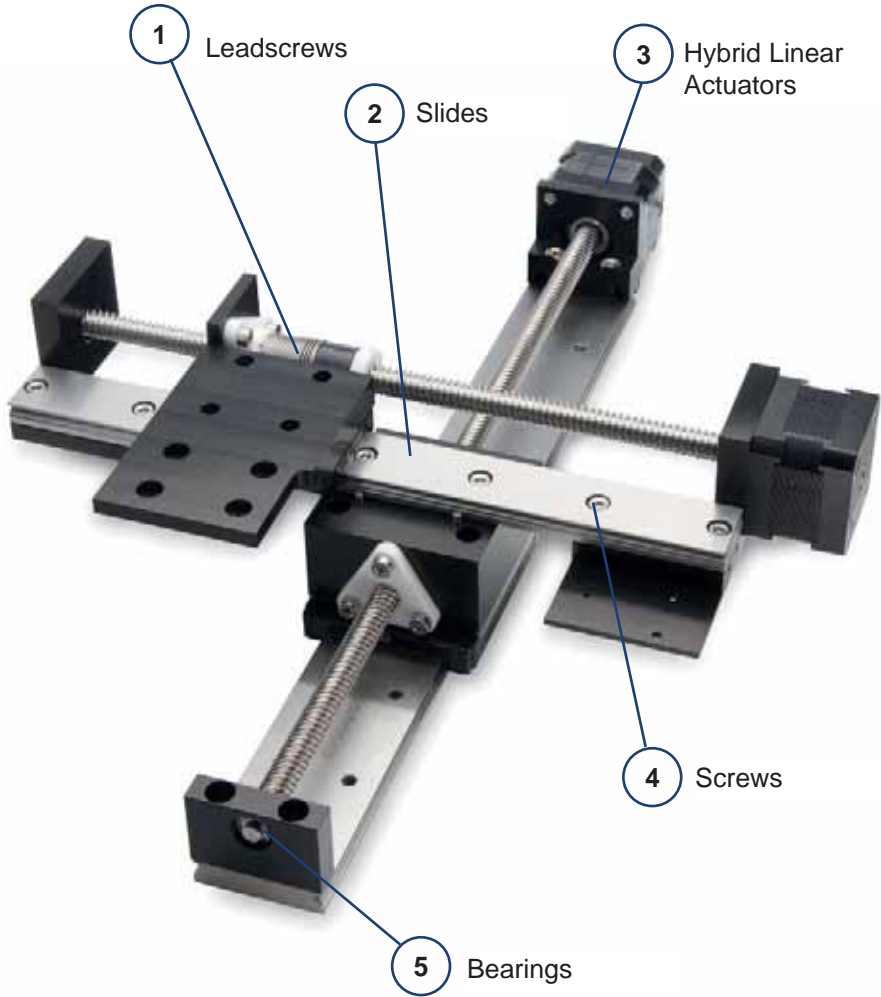





- ① Precision Anti-Backlash Leadscrew and Nut Assemblies  
Section 7



- ② Linear Guides and Slides  
Section 9



- ③ Hybrid Linear Actuators  
Section 2



- ④ Machine Screws, Dowel Pins and Circlips  
Section 13



- ⑤ Shaft Bearings  
Section 12



Applications Engineering

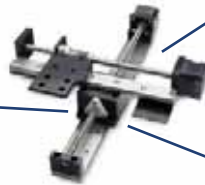

Bracket Manufacture



Assembly and Test



### Leadscrew actuator

A geared leadscrew actuator which provides low backlash and quiet operation, whilst balancing the difficulties of high speed and non-backdrivability.

Systems Overview





- ① Precision Pin Hub and Clamp Hub Gears  
Section 4



- ② Bespoke Leadscrew and Nut Assembly  
Section 7



- ③ Machine Screws, Circlips and Hardware  
Section 13

- ④ Shaft Bearings  
Section 12



Design and Development



Housing Manufacture



Assembly and Test



## Bespoke geared system

A ring gear motion control system containing an actuation motor with integral brake and with separate coarse and fine positional feedback.







System design to specification

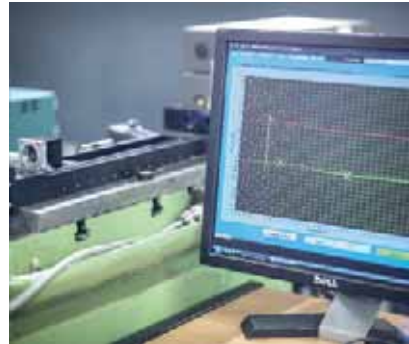

Prototyping and validation testing



Gear manufacture

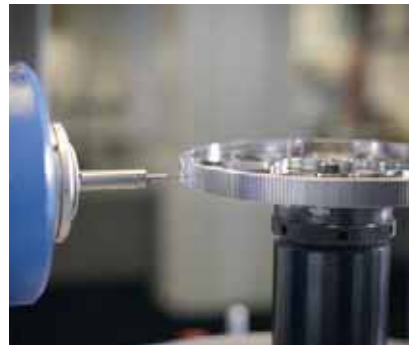

Gear metrology



Housing manufacture



Electro-mechanical assembly



### **Opto-mechanical assembly**

An opto-mechanical switch assembly combining precision motion control with precise optical placement.

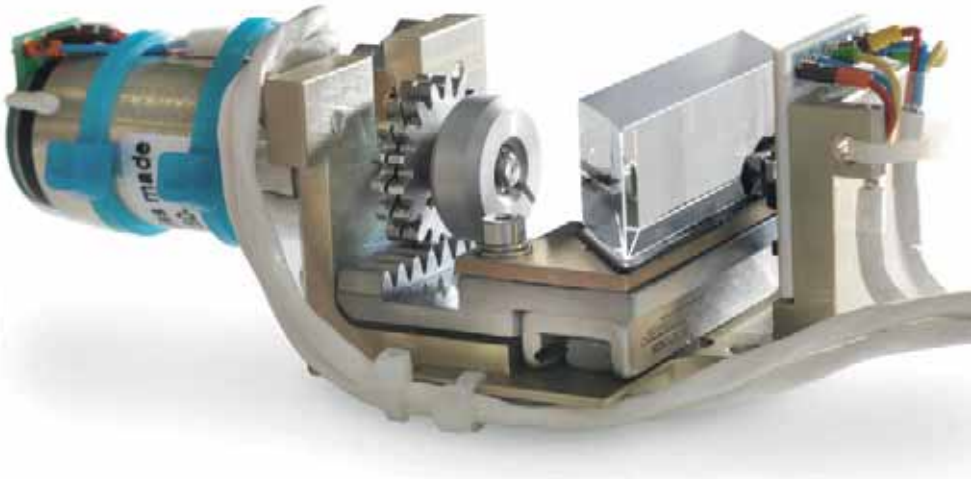



Catalogue gears



Rack and housing manufacture



Optic inspection



Wiring



Opto-mechanical assembly



Recyclable packaging

Systems Overview

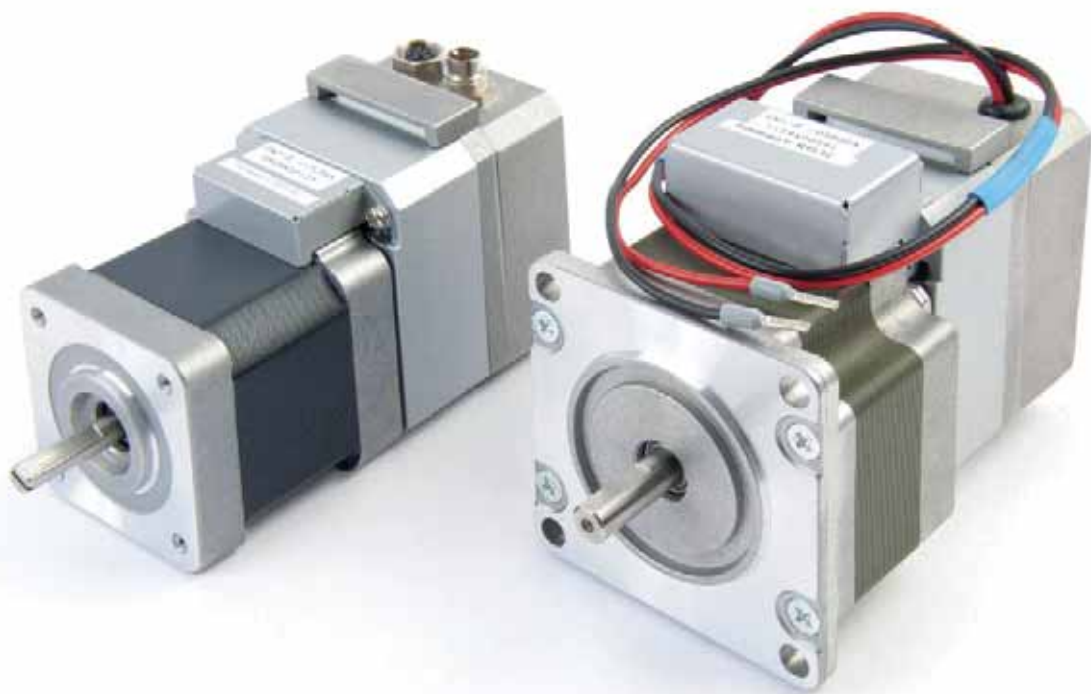

# Section Contents

- Reliance Cool Muscle Motor - Overview .....Page 2-2
  - RCM1 Motor NEMA 11 .....Page 2-4
  - RCM1 Motor NEMA 17 .....Page 2-6
  - RCM1 Motor NEMA 23 .....Page 2-8
  - Specifications and Cables .....Page 2-10
  - Accessories .....Page 2-12
  - Associated Products .....Page 2-13
- Reliance Rack Actuators - Overview .....Page 2-14
  - Tubular Rack Actuators Size 17 .....Page 2-15
  - Solid Rack Actuators Size 17 .....Page 2-16
  - Solid Rack Actuators Size 23 .....Page 2-17
- Bespoke Motorised Actuators.....Page 2-18
- Reliance Cool Muscle Stage - Overview.....Page 2-19
  - Reliance Cool Muscle Stage Size 17 .....Page 2-20
  - Reliance Cool Muscle Stage Size 23 .....Page 2-22
- Linear Actuators - Overview .....Page 2-24
- Linear Rail Actuator - Overview .....Page 2-26
  - Linear Rail Actuator Size 17 .....Page 2-27
- Motorised Leadscrew Linear Slide - Overview .....Page 2-28
- Technical Information.....Page T2-1





## A complete motion control solution

This cost-effective miniature servo system combines a precision stepper motor and high resolution encoder with sophisticated drive and control electronics in a single, compact unit.



- NEMA sizes 11, 17 and 23 each with two frame lengths
- Encoder resolution of 50,000 counts per revolution
- Speeds from 0 to 3,000 RPM
- Continuous torques from 0.027 to 0.87 Nm (1.24 Nm peak)
- H-infinity controller and vector drive for fully closed loop control of position, speed and torque. Tuning not required in most applications.
- Fully programmable for standalone operation
- RS232 and USB communications as standard
- Options for RS485 and Ethernet
- Digital and analogue input and output
- Safe and efficient 24V DC operation

Compared with an equivalent size of stepper motor Cool Muscle works faster, with more available torque, it is more efficient and generates less heat.

Closed loop control means no step loss. In an open loop system it is possible for the motor to fail to move the exact number of steps if it is overloaded. Cool Muscle, being a closed loop control system, is able to identify any potential for step loss and to correct it.

Cool Muscle is available with two types of control interface: Pulse Type (P) and Computer Type (C). The P-Type is applicable for a drive and stepper system with step-pulse control, such as a PLC. Cool Muscle provides an effective drop-in solution to resolve step loss problems and also provides a more integrated solution, having a combined stepper and drive. The C-Type offers a higher level of computer control in a single integrated unit which can remove the need for a separate controller or, in more complex systems, reduce the investment required in additional controllers.

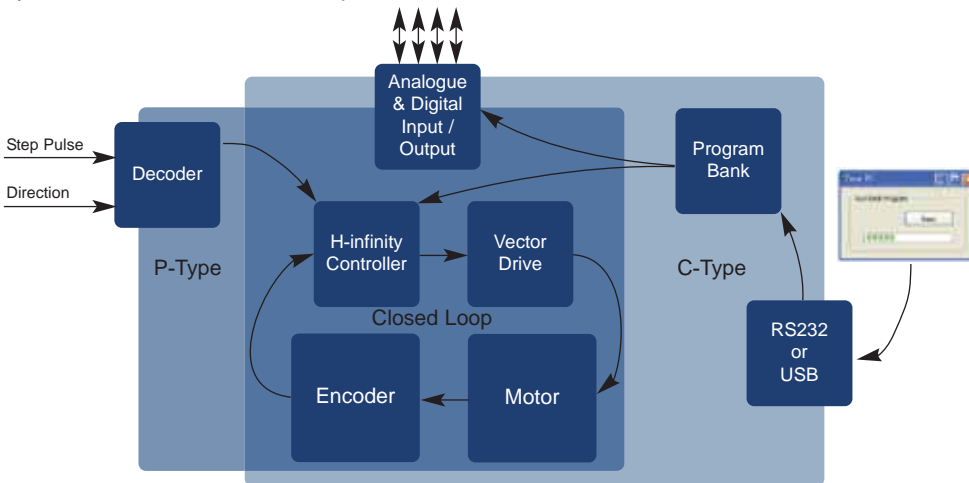



Cool Muscle's unique features include the ability to link up to 15 motors which can operate together in complex sequences without an additional controller. Cool Muscle is able to use a physical limit of travel as its reference position, using torque sensing to safely and accurately find the limits of travel without needing a position sensor (e.g. limit switch).

The high level of integration provided by Cool Muscle reduces cabling, keeps components to a minimum and speeds up system assembly.

Cool Muscle is ideal for laboratory and test equipment or for light industrial automation.



Customised XYZ positioning table



Precision linear stage

Intelligent  
Motors



Medical pipetting systems



Laboratory automation

## Motorised actuators

Reliance supplies pre-built motion stages with integrated Cool Muscle motors, see [page 2-19](#). We also manufacture unique, high-speed precision rack actuators fitted with Cool Muscle, available with solid racks or tubular racks, ideal for pipette systems, see [page 2-14](#).



All dimensions in mm

**Associated Products**

- Couplings: page 8-1
- Leadscrews: page 7-1
- Hardware: page 13-1
- Cables: page 2-11

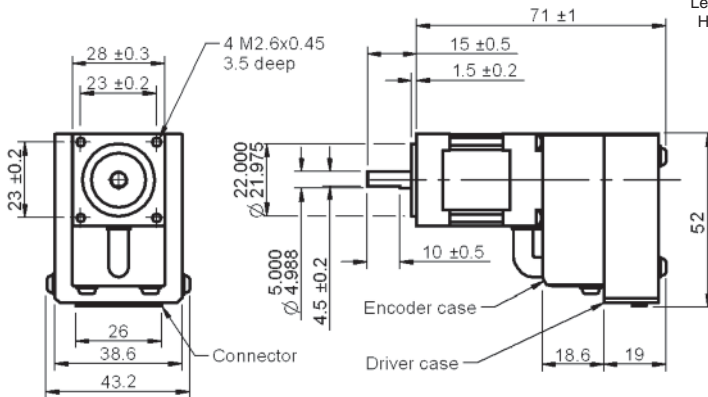

## RCM1 - P - 11 S 30 - RT3

Generation  
Interface  
P = Pulse  
C = Computer  
Speed  
30 = 3000 rpm

### Specification table

|   | <b>RCM1-□-11S30-RT3</b> |
|---|-------------------------|
| Motor output power  | 9 W                     |
| Maximum speed   | 3,000 rpm               |
| Continuous torque   | 0.027 Nm                |
| Peak torque   | 0.039 Nm                |
| Load inertia allowance  | 80 g-cm <sup>2</sup>    |
| Motor inertia   | 8g -cm <sup>2</sup>     |
| Input supply current rated<br>(Continuous torque/rated peak torque) | 0.8 A/1.0 A             |
| Weight  | 246 g                   |

### Torque curve

RCM1-□-11S30-RT3

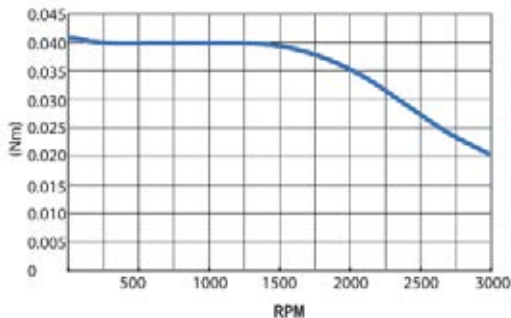

### Technical support

- Product overview - see page 2-2
- Technical information - see page T2-1
- P & C interface - see page T2-2
- Software interface - see page T2-3
- Electrical interface - see page T2-5
- Cables - see page 2-11
- Accessories - see page 2-12



**Associated Products**

Couplings: page 8-1  
Leadscrews: page 7-1  
Hardware: page 13-1  
Cables: page 2-11

All dimensions in mm

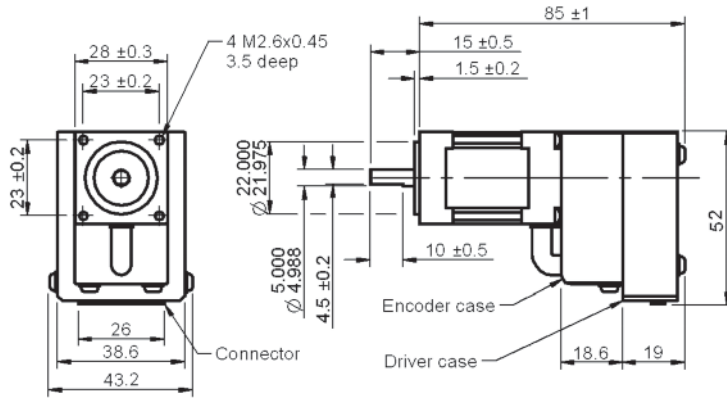

**RCM1 - P - 11 L 30 - RT3**

Generation  
Interface  
P = Pulse  
C = Computer  
Speed  
30 = 3000 rpm

**Specification table**

|   | <b>RCM1-□-11L30-RT3</b> |
|---|-------------------------|
| Motor output power  | 18 W                    |
| Maximum speed   | 3,000 rpm               |
| Continuous torque   | 0.055 Nm                |
| Peak torque   | 0.078 Nm                |
| Load inertia allowance  | 180 g-cm <sup>2</sup>   |
| Motor inertia   | 18 g-cm <sup>2</sup>    |
| Input supply current rated<br>(Continuous torque/rated peak torque) | 1.2 A/1.5 A             |
| Weight  | 300 g                   |

**Torque curve**

RCM1-□-11L30-RT3

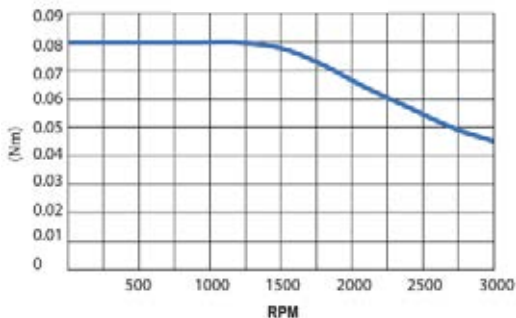

**Technical support**

- Product overview - see page 2-2
- Technical information - see page T2-1
- P & C interface - see page T2-2
- Software interface - see page T2-3
- Electrical interface - see page T2-5
- Cables - see page 2-11
- Accessories - see page 2-12



All dimensions in mm

**Associated Products**

- Planetary Gearboxes: page 3-3
- Couplings: page 8-1
- Leadscrews: page 7-1
- Hardware: page 13-1
- Cables: page 2-11

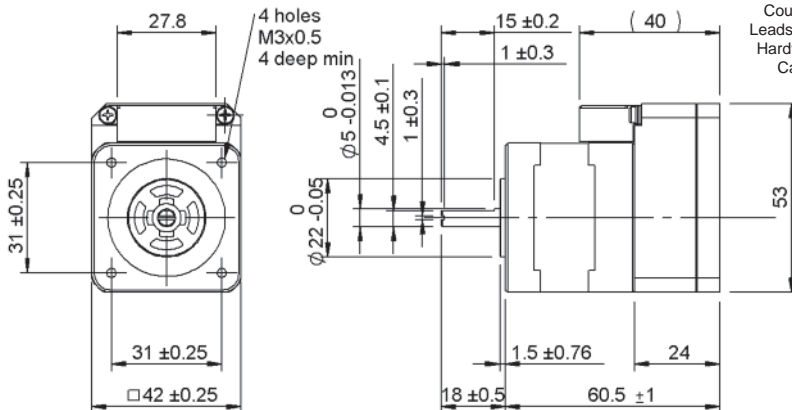

**RCM1 - P - 17 S 30-C - RT3**

Generation ———  
 Interface ——— P = Pulse  
                   C = Computer  
 Speed ——— 30 = 3000 rpm

**Specification table**

|   | <b>RCM1- □ -17S30-C-RT3</b> |
|---|-----------------------------|
| Motor output power  | 18 W                        |
| Maximum speed   | 3,000 rpm                   |
| Continuous torque   | 0.082 Nm                    |
| Peak torque   | 0.117 Nm                    |
| Load inertia allowance  | 380 g-cm <sup>2</sup>       |
| Motor inertia   | 36 g-cm <sup>2</sup>        |
| Input supply current rated<br>(Continuous torque/rated peak torque) | 0.8 A/1.0 A                 |
| Weight  | 325 g                       |

**Torque curve**

**RCM1- □ -17S30-C-RT3**

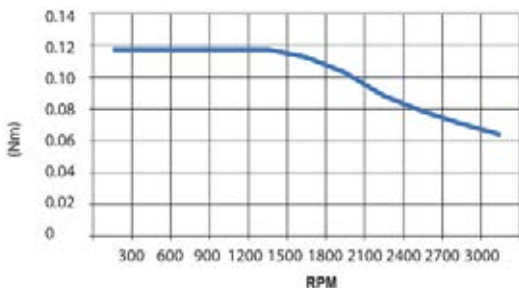

**Technical support**

- Product overview - see page 2-2
- Technical information - see page T2-1
- P & C interface - see page T2-2
- Software interface - see page T2-3
- Electrical interface - see page T2-5
- Cables - see page 2-11
- Accessories - see page 2-12



### Associated Products

- Planetary Gearboxes: page 3-3
- Couplings: page 8-1
- Leadscrews: page 7-1
- Hardware: page 13-1
- Cables: page 2-11

All dimensions in mm

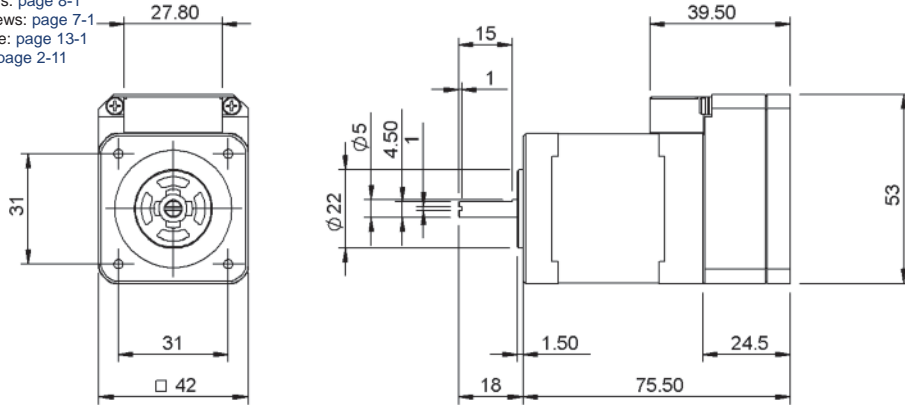

### RCM1 - P - 17 L 30-C - RT3

Generation  
Interface  
P = Pulse  
C = Computer  
Speed  
30 = 3000 rpm

### Specification table

|   | RCM1- □ -17L30-C-RT3  |
|---|-----------------------|
| Motor output power  | 18 W                  |
| Maximum speed   | 3,000 rpm             |
| Continuous torque   | 0.36 Nm               |
| Peak torque   | 0.518 Nm              |
| Load inertia allowance  | 760 g-cm <sup>2</sup> |
| Motor inertia   | 74 g-cm <sup>2</sup>  |
| Input supply current rated<br>(Continuous torque/rated peak torque) | 1.5 A/1.8 A           |
| Weight  | 470 g                 |

### Torque curve

RCM1- □ -17L30-C-RT3

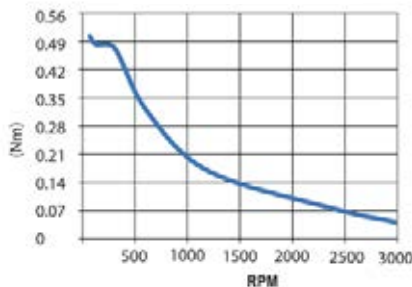

### Technical support

- Product overview - see page 2-2
- Technical information - see page T2-1
- P & C interface - see page T2-2
- Software interface - see page T2-3
- Electrical interface - see page T2-5
- Cables - see page 2-11
- Accessories - see page 2-12





All dimensions in mm

**Associated Products**

- Planetary Gearboxes: page 3-3
- Couplings: page 8-1
- Leadscrews: page 7-1
- Hardware: page 13-1
- Cables: page 2-11

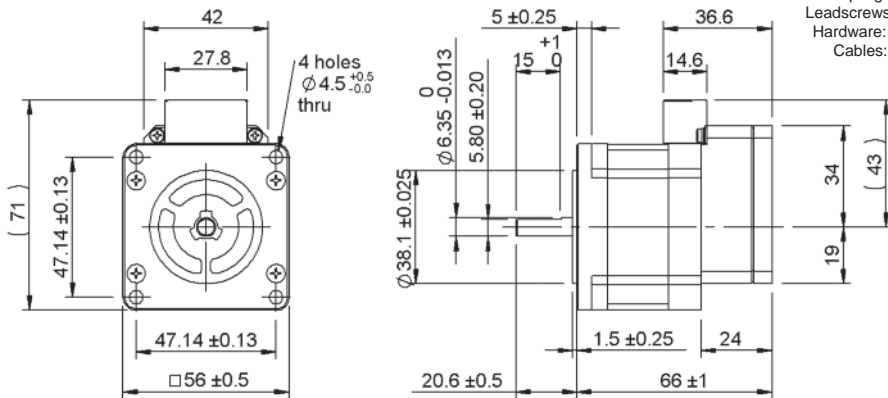

**RCM1 - P - 23 S 30-C - RT3**

Generation  
Interface P = Pulse  
C = Computer  
Speed 30 = 3000 rpm

**Specification table**

|   | RCM1- □ -23S30-C-RT3                  |
|---|---------------------------------------|
| Motor output power  | 45 W                                  |
| Maximum speed   | 3,000 rpm                             |
| Continuous torque   | 0.29 Nm                               |
| Peak torque   | 0.42 Nm                               |
| Load inertia allowance  | 1.0x10 <sup>3</sup> g-cm <sup>2</sup> |
| Motor inertia   | 1.0x10 <sup>2</sup> g-cm <sup>2</sup> |
| Input supply current rated<br>(Continuous torque/rated peak torque) | 3.9 A/5.1 A                           |
| Weight  | 580 g                                 |

**Torque curve**

RCM1- □ -23S30-C-RT3

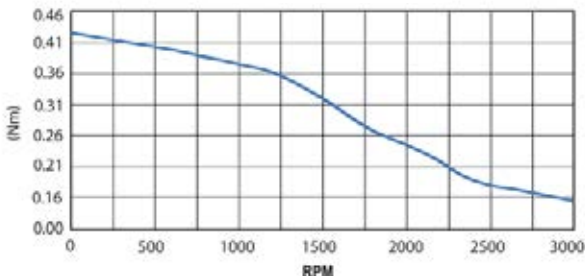

**Technical support**

- Product overview - see page 2-2
- Technical information - see page T2-1
- P & C interface - see page T2-2
- Software interface - see page T2-3
- Electrical interface - see page T2-5
- Cables - see page 2-11
- Accessories - see page 2-12



### Associated Products

Planetary Gearboxes: page 3-3  
Couplings: page 8-1  
Leadscrews: page 7-1  
Hardware: page 13-1  
Cables: page 2-11

All dimensions in mm

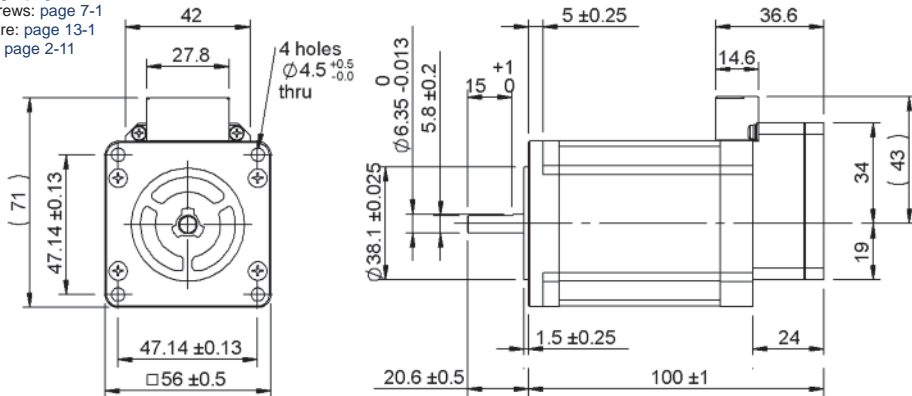

### RCM1 - P - 23 L 20-C - RT3

Generation  
Interface  
P = Pulse  
C = Computer  
Speed  
20 = 2000 rpm

### Specification table

|   | RCM1- □ -23L20-C-RT3                  |
|---|---------------------------------------|
| Motor output power  | 30 W                                  |
| Maximum speed   | 2,000 rpm                             |
| Continuous torque   | 0.87 Nm                               |
| Peak torque   | 1.24 Nm                               |
| Load inertia allowance  | 3.6x10 <sup>3</sup> g-cm <sup>2</sup> |
| Motor inertia   | 3.6x10 <sup>2</sup> g-cm <sup>2</sup> |
| Input supply current rated<br>(Continuous torque/rated peak torque) | 2.6 A/3.4 A                           |
| Weight  | 1100 g                                |

### Torque curve

RCM1- □ -23L20-C-RT3

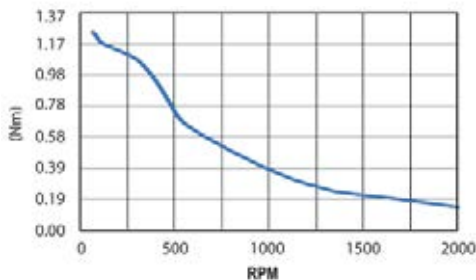

### Technical support

- Product overview - see page 2-2
- Technical information - see page T2-1
- P & C interface - see page T2-2
- Software interface - see page T2-3
- Electrical interface - see page T2-5
- Cables - see page 2-11
- Accessories - see page 2-12



## General and environmental specifications

|   |  |
|---|--|
| Encoder                                       | Incremental magnetic encoder<br>(50,000 pulses per rotation)                             |
| Control Method                                | Closed loop vector control   |
| Input Supply Voltage                          | DC24 V±10%   |
| Resolution Pulse Rotation<br>(Pulse/Rotation) | 200, 400, 500, 1000(default), 2000, 2500,5000,<br>10000, 25000,50000 Select by parameter |
| Ambient Operating Temperature                 | 0°C to 40°C  |
| Storage Temperature                           | -20°C to +60°C   |
| Operating Humidity                            | Less than 90%RH  |
| Shock   | Less than 10 G   |
| Vibration                                     | Less than 1 G  |

## Pin layout

For Reliance Cool Muscle electrical interfacing and connector pin layout see Technical Information page T2-5.

## Input/output signal

| Pulse Interface  | CW/CCW  | Step/Direction  |
|--|---|---|
| <br>Input Signal<br>Pulse Input | CW/CCW Pulse  | Step Pulse  |
|  | Maximum frequency: 500 Kpps<br>Minimum pulse width: 0.8 µsec<br>Voltage level H (with pulse) > +3.0 V<br>(+24 Vmax) 7 mA-1 5mA<br>Voltage level L (no pulse) < +0.8 V | Maximum frequency: 500 Kpps<br>Minimum pulse width: 0.8 µsec<br>Voltage level H (with pulse) > +3.0 V<br>(+24 Vmax) 7 mA-15 mA<br>Voltage level L (no pulse) < +0.8 V |

### Variable Voltage Interface - Now integrated into the C-Type motor

|  |   |
|--|---|
| <br>Input Signal<br>Analogue Input | Speed Ccontrol setting  |
|  | Increase the voltage from 2.6 V to 4.8 VDC to increase speed in the CW direction<br>Decrease the voltage from 2.4 V to 0 VDC, to increase speed in the CCW direction. Use OP AMP for maximum resolution<br>Position control setting<br>Travel distance is proportionate to voltage input (between 0 V and 4.8 VDC)<br>Maximum travel distance is set by a parameter |

### Computer Control Interface

|   |   |
|---|---|
| <br>Input Signal<br>Control<br>Level | Via supplied cabling - motor interface is TTL, please specify RS232 or RS485 interface option |
|   | Voltage level high> 3 V (minimum 7 mA)      Voltage level low< 0.8 V                          |

### RT3 Real Time Interface

|                     |  |
|---------------------|--|
| Co-ordinated Motion | Allows 2 axes to work together to create accurate complex motion                                       |
| Logic Banks         | Embedded PLC up to 200 steps for mathematical calculation of motion                                    |
| Quadrature          | Simulated AB outputs from the magnetic encoder. Maximum frequency 20 kHz                               |
| Shared I/O          | Inputs or outputs are available to be read and accessed by all motors running programs and logic banks |



## Software interface

For programming details for the C-Type Reliance Cool Muscle see Technical Information pages T2-3 to T2-5.

## 'Y' cables



### RCM1C3 - xx

Length of wires to first connector  
(xx-xx if the two lengths are different)

Generic part number

## Standard and customised daisy chain cables

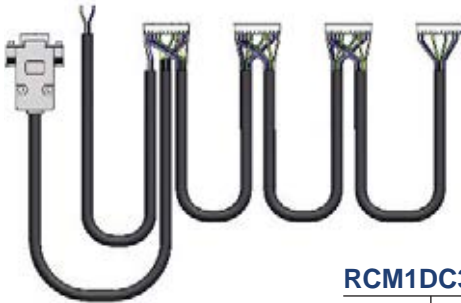

### RCM1DC3A - xx - N - xx - xx - xx

Length of wire between connectors  
(Only one number required if the lengths are all the same)

Number of connectors

Length of wires to first connector  
(xx-xx if the two lengths are different)

Generic part number

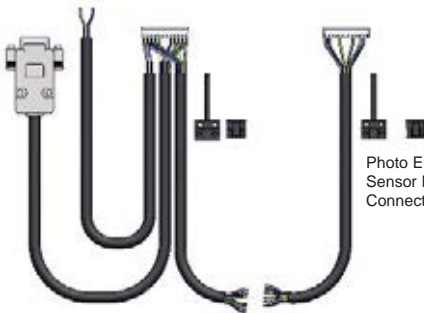

Photo Electric  
Sensor Molex  
Connector 2 way

### **i** Product options

- For further information about customising cables, please contact us
- Customised cables are available with photosensors option



### Communication cards

RS485, PROFIBUS and Ethernet cards are available as options for the Reliance Cool Muscle servo system. Our engineers provide technical support based on extensive experience integrating the Reliance Cool Muscle with third party controllers, HMIs and PLCs.



### Power supply

Designed specifically for the Reliance Cool Muscle, this power supply is built to withstand the current draw spikes which the hard stops or starts often require. Specification of the power supply is 150 W/300 W, 6 A/10 A.



### Cables

A standard motor cable (40 cm) and varistor are supplied with every motor. Longer motor cables are available as an option.

A Y-cable is required to connect the Reliance Cool Muscle to a USB or serial port, see [page 2-11](#)

Multi-motor custom cables can be made to suit your application.



### Control room

Control Room is a free application which provides basic tools for setting parameters and creating motion profiles. A user friendly interface makes it easy to work with the Reliance Cool Muscle.

Control Room replaces the CoolWorks software.

CoolWorks continues to be supported by Reliance.



Intelligent Motors



We provide a range of associated products which compliments the Reliance Cool Muscle and enhance its performance, including couplings, gearboxes and linear motion components.



### Reli-a-Flex® flexible shaft couplings

The Reli-a-Flex® range of one piece slit couplings has been specially designed to provide accurate transfer of motion between two rotating shafts while at the same time catering for parallel and angular misalignment as well as protecting the bearing systems. See page 8-6 for more information on the Reli-a-Flex® range.



### Planetary gearboxes

A range of high quality planetary gearboxes is available to suit your application needs. Combine a low backlash, zero maintenance and high durability gearhead with the Reliance Cool Muscle to maximise performance. Available in NEMA 17 and 23, ratios 3:1 to 512:1. See page 3-3 for more information.



### Intelligent actuator systems

A range of intelligent actuators is available to support your precision motion control needs. These include rack actuators and positioning stages for use with the Reliance Cool Muscle. Please contact us or visit the website for more information; [www.reliance.co.uk/shop](http://www.reliance.co.uk/shop) See pages 2-14 to 2-23 for more information.







## Precise, efficient linear motion

This compact actuation system combines the Reliance Cool Muscle servo system with a rack and pinion drive to give precise linear motion for high speed applications.



Multiple configurations are available developing peak forces up to 150 N and rated speeds of 300 mm per second, with resolutions of better than 1 micron and standby power consumption of less than 1.7 watts. The assembly has a number of different mounting options for ease of mechanical installation.

The Racktuator™ has built-in closed loop control with an integrated 32 bit CPU, magnetic encoder and PLC. This intelligent assembly can be programmed to decide for itself where it should be at any given time and to send out continuous motion data such as speed, position and torque. The unit is fully integrated, saving space and cost, and makes system integration faster and simpler with control at the point of use. The Racktuator™ is fully programmable and can store onboard discrete

positions, speeds, accelerations, timers, torque limits and custom variables, all to be recalled by up to 15 separate motion control programs. It also has built-in maths and S curve functions for advanced motion control.

Multiple Racktuators™ can work in sequence, either to produce circles, ellipses, or complex arc motions, or in a daisy chain network to automate pick-and-place machines. The Racktuator™ can be operated independently or communicate with a PC host via RS232 or USB. It can also be fitted with a traditional stepper motor, being driven by step and direction signals or with CW/CCW pulses to bring the advantages of an AC servo system to any stepper motor application.

The Racktuator™ is available with both solid and tubular racks, suitable for a variety of applications from scientific research to food preparation and packaging.



Laboratory automation



Industrial automation



### Associated Products

Hardware: page 13-1

All dimensions in mm

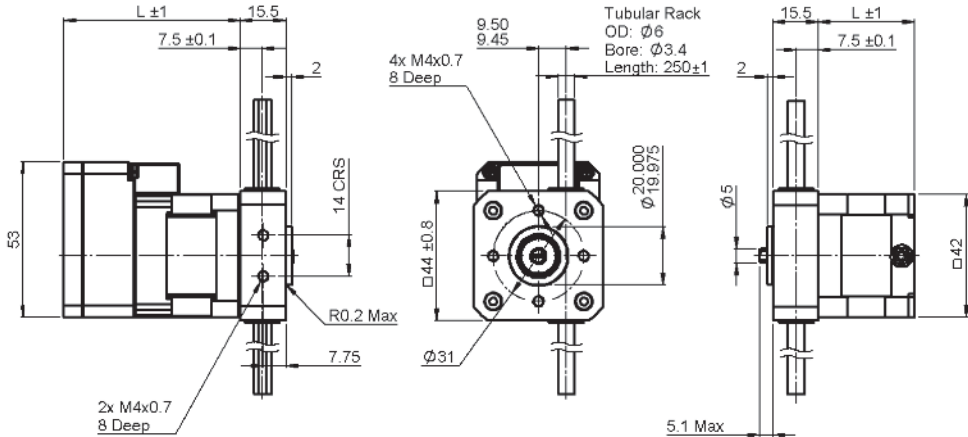

Reliance Cool Muscle Motor Option

Hybrid Stepper Motor Option

## Part number selection table

| Part Number               | Motor                                   | Pinion Material | L    | Axial Load (N) | Momentary Load (N) | Travel Range (mm) |
|---------------------------|---|-----------------|------|----------------|--------------------|-------------------|
| <b>RCMRA17S-6-250-C</b>   | Reliance Cool Muscle Motor <sup>1</sup> | PEEK            | 60.5 | 3              | 12                 | 200               |
| <b>RCMRA17L-6-250-C-S</b> |   | St steel        | 75.3 | 15             | 25                 |                   |
| <b>RRA17-6-250</b>        | Hybrid Stepper Motor <sup>2</sup>       | PEEK            | 33.0 | 3              | 12                 |                   |
| <b>RRA17-6-250-S</b>      |   | St steel        | 33.0 | 15             | 25                 |                   |

<sup>1</sup> Reliance Cool Muscle motor option, see pages 2-6 and 2-7 for motor details (if a pulse interface is required change -C to a -P)

<sup>2</sup> Hybrid stepper motor option, see page T2-10 for motor details

## Technical specification

|                              | RCMRA17<br>Reliance Cool Muscle  | RRA17<br>Hybrid Stepper                           |
|------------------------------|----------------------------------|---|
| Resolution                   | 0.00085 mm with 50,000 steps/rev | 0.21 mm with 200 steps/rev                        |
| Max speed                    | 300 mm/sec                       |   |
| Temperature range            | Between 0°C and 40°C             | Between -20°C and +50°C                           |
| Repeatability                | 0.025 mm                         |   |
| Side wobble (fully extended) | ±0.2 mm                          |   |
| Life time                    | 5 million cycles minimum         |   |
| Wire length                  | N/A                              | 200 mm  |
| Backlash                     | 0.08 mm linear movement          |   |
| Rack material                | 316 grade stainless steel        |   |
| Lubrication                  | St steel                         | PTFE based grease                                 |
|                              | PEEK                             | Lubrication free, provides smooth quiet operation |

## Technical support

- Product overviews see pages 2-2, 2-14 and 6-2
- Technical information see pages T2-9 and T6-1



All dimensions in mm

Associated Products

Hardware: page 13-1

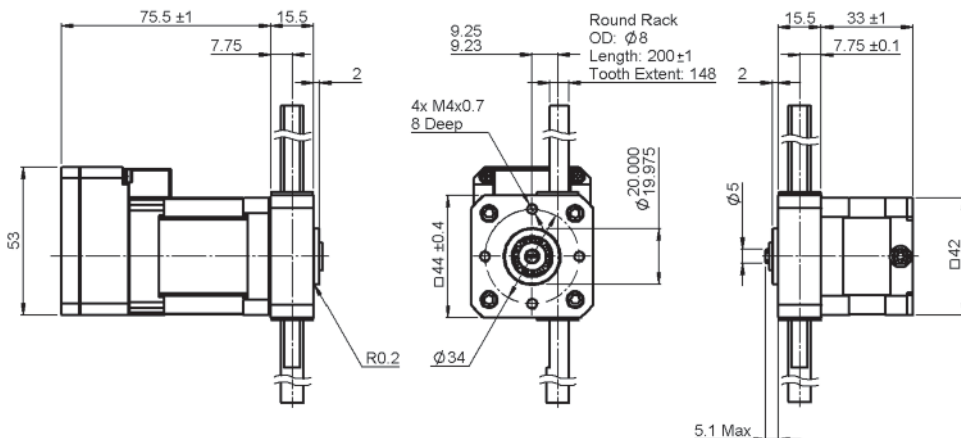

Reliance Cool Muscle Motor Option

Hybrid Stepper Motor Option

## Part number selection table

| Part Number       | Motor                                   | Pinion Material | Axial Load (N) | Momentary Load (N) | Travel Range (mm) |
|-------------------|---|-----------------|----------------|--------------------|-------------------|
| RCMRAK17L-8-200-C | Reliance Cool Muscle Motor <sup>1</sup> | St steel 304    | 25             | 50                 | 100               |
| RRAK17-8-200      | Hybrid Stepper Motor <sup>2</sup>       |                 | 25             | 50                 |                   |

<sup>1</sup> Reliance Cool Muscle motor option, see page 2-7 for motor details (if a pulse interface is required change -C to a -P)

<sup>2</sup> Hybrid stepper motor option, see page T2-5 for motor details

## Technical information

|                              | RCMRAK17<br>Reliance Cool Muscle | RRAK17<br>Hybrid Stepper  |
|------------------------------|----------------------------------|---------------------------|
| Resolution                   | 0.00075 mm with 50,000 steps/rev | 0.19mm with 200 steps/rev |
| Max speed                    | 500 mm/sec                       |                           |
| Temperature range            | Between 0°C and +40°C            | Between -20°C and +50°C   |
| Repeatability                | 0.025 mm                         |                           |
| Side wobble (fully extended) | ±0.29 mm                         |                           |
| Life time                    | 5 million cycles minimum         |                           |
| Wire length                  | N/A                              | 200 mm                    |
| Backlash                     | 0.08 mm linear movement          |                           |
| Rack material                | 304 grade stainless steel        |                           |
| Lubrication                  | PTFE based grease                |                           |

## Technical support

- Product overviews see pages 2-2, 2-14 and 6-2
- Technical information see pages T2-9 and T6-1



### Associated Products

Hardware: page 13-1

All dimensions in mm

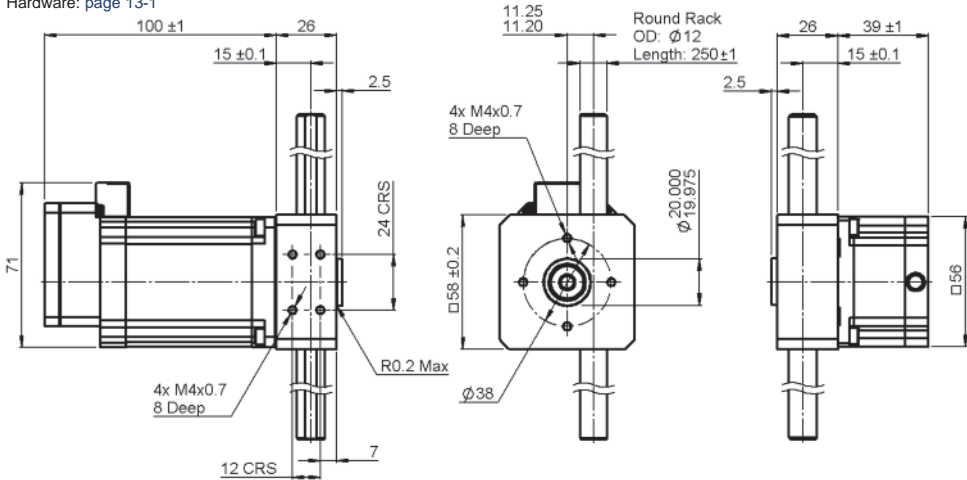

### Reliance Cool Muscle Motor Option

### Part number selection table

| Part Number              | Motor                                   | Pinion Material        | Axial Load (N) | Momentary Load (N) | Travel Range (mm) |
|--------------------------|---|------------------------|----------------|--------------------|-------------------|
| <b>RCMRA23L-12-250-C</b> | Reliance Cool Muscle Motor <sup>1</sup> | St steel 17-4Ph coated | 90             | 150                | 150               |
| <b>RRA23-12-250</b>      | Hybrid Stepper Motor <sup>2</sup>       |                        | 90             | 150                |                   |

<sup>1</sup> Reliance Cool Muscle motor option, see page 2-9 for motor details (if a pulse interface is required change -C to a -P)

<sup>2</sup> Hybrid stepper motor option, see page T2-5 for motor details

### Technical information

|                                 | RCMRA23<br>Reliance Cool Muscle                  | RRA23<br>Hybrid Stepper   |
|---------------------------------|--|---------------------------|
| Resolution                      | 0.0008 mm with 50,000 steps/rev                  | 0.2 mm with 200 steps/rev |
| Max speed                       | 300 mm/sec                                       |                           |
| Temperature range               | Between 0°C and 40°C                             | Between -10°C and +50°C   |
| Repeatability                   | 0.012 mm   |                           |
| Side wobble (50mm from housing) | ±0.2 mm  |                           |
| Life time                       | 5 million cycles minimum (based on 40 mm stroke) |                           |
| Wire length                     | N/A  | 200 mm                    |
| Backlash                        | 0.06 mm linear movement                          |                           |
| Rack material                   | 440B grade stainless steel                       |                           |
| Lubrication                     | PTFE based grease                                |                           |

### Technical support

- Product overviews see pages 2-2, 2-14 and 6-2
- Technical information see pages T2-9 and T6-1



## Providing custom-built solutions

As well as offering a range of standard actuators Reliance is able to develop bespoke solutions to suit individual requirements. Bespoke motorised actuators are based on our range of catalogue components and assemblies, together with housings and fittings manufactured by Reliance in the UK and Ireland.



XYZ theta stage

Working closely with our customers to understand the application and design specification, we are able to offer design engineering support to help develop an appropriate assembly, bringing knowledge and experience from working in a variety of industries and applications.

Typical examples shown below include a miniature motorised leadscrew actuator for a drug dispensing system, a motorised leadscrew driven slide assembly, using multiple Reliance Cool Muscle motors, for an XYZ theta position system, and a 3-axis rotary-linear actuator for a medical scanner.



Actuator for a medical scanner



Modular linear actuator

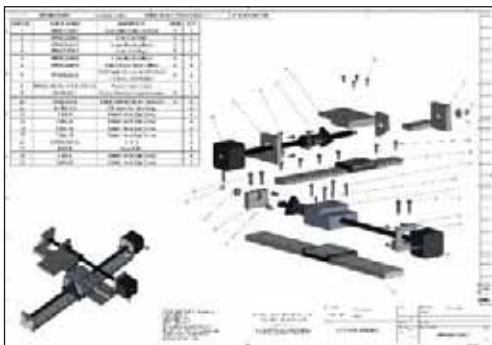

Design engineering support



Manufacturing and assembly



## Motorised leadscrew-driven linear slide

The RCMS series of leadscrew stages combines the high speeds and programmability of Reliance Cool Muscle motors with the accuracy and reliability of a leadscrew-driven linear slide.



The RCMS is available with two different motor sizes and in a wide range of travel lengths and leadscrew and carriage configurations.

The precision slide's aluminium guide and carriage are driven by a rolled stainless steel leadscrew, available with metric and imperial leads. High performance polymers and TFE coating extend the life of the slide's moving parts.

The Reliance Cool Muscle motor, in NEMA sizes 17 and 23, integrates an efficient vector drive and H-infinity controller with a 50,000-count encoder to form a servo positioning system operating at speeds from 0 to 3,000 rpm with minimum power consumption. Cool Muscle's torque sensing and software travel limits give the option of eliminating home and limit switches from your system.

Typical applications for the RCMS include test instrumentation used in industrial automation and university laboratory research equipment used by the energy industry.

Intelligent Motors



Test equipment for solar cell manufacture



Packaging test equipment





All dimensions in mm unless otherwise stated

Associated Products  
Hardware: page 13-1

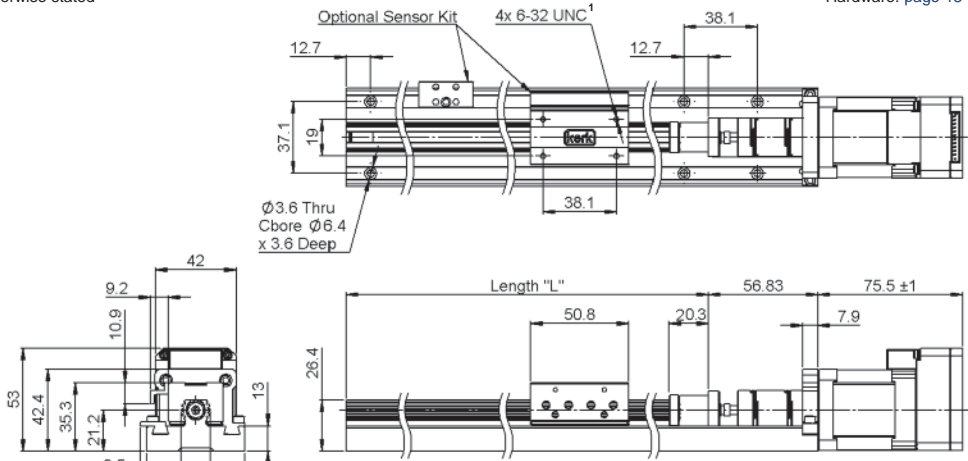

Travel distance = L - Carriage Length - Bearing Support

| Length Tolerances |        |
|-------------------|--------|
| 4 < L ≤ 16        | ± 0.1  |
| 16 < L ≤ 63       | ± 0.15 |
| 63 < L ≤ 250      | ± 0.2  |
|                   | ± 0.3  |

## Part number selection table

| Example Part No. <u>RCMS17L-M04-C-1-18</u> |                      |                                 |                            |                                |                    |                                 |                |
|--|----------------------|---------------------------------|----------------------------|--------------------------------|--------------------|---------------------------------|----------------|
| Basic Part Number                          | Screw Lead mm (Inch) | Motor Interface <sup>2</sup>    | No. Carriages <sup>3</sup> | Linear Resolution (Default) mm | Max Drag Torque Nm | Standard Guide Lengths "L" Inch |                |
| RCMS17L-M02                                | 2.0                  | C<br>(Computer)<br>P<br>(Pulse) | 1                          | 0.002                          | 0.03               | 12 18                           |                |
| RCMS17L-M04                                | 4.0                  |                                 |                            | 0.004                          | 0.04               | 12 18                           |                |
| RCMS17L-M12                                | 12.0                 |                                 |                            | 0.012                          | 0.04               | 12 24                           |                |
| RCMS17L-M25                                | 25.0                 |                                 | 2                          | 0.025                          | 0.05               | 18 24                           |                |
| RCMS17L-0100                               | (0.100)              |                                 |                            | 3                              | 0.00254            | 0.03                            | 10 12 15 18 24 |
| RCMS17L-0200                               | (0.200)              |                                 |                            |                                | 0.00508            | 0.04                            | 10 12 15 18 24 |
| RCMS17L-0500                               | (0.500)              |                                 | 0.0127                     |                                | 0.04               | 12 15 18 24                     |                |
| RCMS17L-1000                               | (1.000)              |                                 |                            | 0.0254                         | 0.05               | 12 18 24 36                     |                |

<sup>1</sup>Metric mounting configuration available, please enquire

<sup>2</sup>For explanation of -C and -P type interfaces, see pages 2-2 and T2-2

<sup>3</sup>Carriage information:

1 = 1 driven carriage

2 = 1 driven and 1 passive carriage

3 = 1 driven and 2 passive carriages



## Technical specification

| Basic Part Number | Life @ ¼ Design Load mm | Torque to Move Carriage Design Load Nm/kg | Carriage Design Load kg | Max Linear Speed mm/sec | Axial Load kg | Screw Inertia kgm <sup>2</sup> /m | Carriage Roll Angle Deg. |
|-------------------|-------------------------|---|-------------------------|-------------------------|---------------|-----------------------------------|--------------------------|
| RCMS17L-M02       | 254x10 <sup>6</sup>     | 0.016                                     | 16                      | 127                     | 5             | 4.2x10 <sup>-6</sup>              | 1                        |
| RCMS17L-M04       |                         | 0.023                                     |                         | 254                     |               |                                   |                          |
| RCMS17L-M12       |                         | 0.039                                     |                         | 635                     |               |                                   |                          |
| RCMS17L-M25       |                         | 0.070                                     |                         | 1270                    |               |                                   |                          |
| RCMS17L-0100      |                         | 0.016                                     |                         | 127                     |               |                                   |                          |
| RCMS17L-0200      |                         | 0.023                                     |                         | 254                     |               |                                   |                          |
| RCMS17L-0500      |                         | 0.039                                     |                         | 635                     |               |                                   |                          |
| RCMS17L-1000      |                         | 0.070                                     |                         | 1270                    |               |                                   |                          |

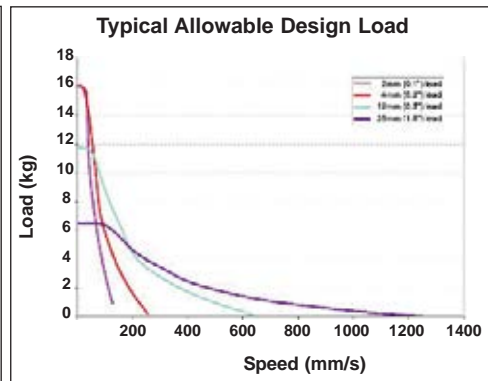
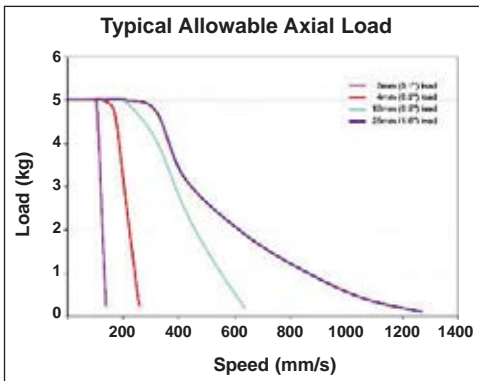

### Typical RCMS Accuracy Graph

Based on 0.500 inch lead with a 3 kg load Backlash <0.003 mm

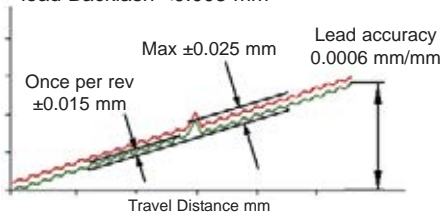

### ? Technical support

- Product overviews - see pages 2-19 and 2-2
- Technical information - see pages T2-1 to T2-8

### i Product options

- Special carriage, rail, screw or metric mounting configurations
- Higher accuracy leadscrew
- Left Hand (LH) or Left/Right (L/R) thread
- Metric leads and guide lengths
- Alternative guide lengths
- Sensor kits, add -S to the end of the part number e.g. RCMS17L-M04-C-1-18-S



All dimensions in mm unless otherwise stated

Associated Products  
Hardware: page 13-1

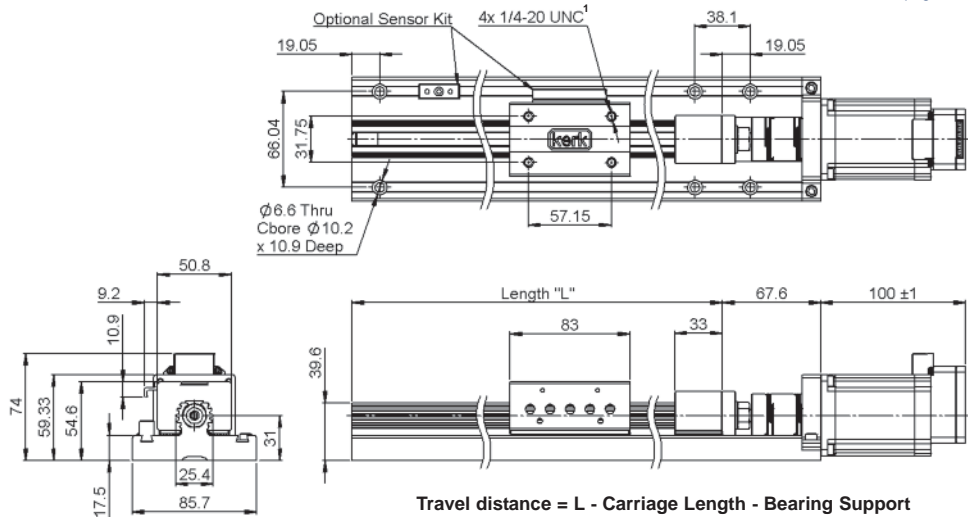

| Length Tolerances |        |
|-------------------|--------|
| < L4              | ± 0.1  |
| 4 < L ≤ 16        | ± 0.15 |
| 16 < L ≤ 63       | ± 0.2  |
| 63 < L ≤ 260      | ± 0.3  |

Part number selection table

| Example Part No.  |                      | <u>RCMS23L-M08-C-1-18</u>       |                            |                                |                    |                                   |
|-------------------|----------------------|---------------------------------|----------------------------|--------------------------------|--------------------|-----------------------------------|
| Basic Part Number | Screw Lead mm (Inch) | Motor Interface <sup>2</sup>    | No. Carriages <sup>3</sup> | Linear Resolution (Default) mm | Max Drag Torque Nm | Standard Guide Lengths "L" (Inch) |
| RCMS23L-M08       | 8.0                  | C<br>(Computer)<br>P<br>(Pulse) | 1                          | 0.0080                         | 0.04               | 18 24                             |
| RCMS23L-0100      | (0.100)              |                                 |                            | 0.00254                        | 0.04               | 12 18 24 36                       |
| RCMS23L-0200      | (0.200)              |                                 | 2                          | 0.00508                        | 0.04               | 12 18 24 36                       |
| RCMS23L-0500      | (0.500)              |                                 |                            | 0.0127                         | 0.05               | 12 18 24 36                       |
| RCMS23L-1000      | (1.000)              |                                 |                            | 0.0254                         | 0.06               | 12 18 24 36                       |

<sup>1</sup>Metric mounting configuration available, please enquire  
<sup>2</sup>For explanation of -C and -P type interfaces, see pages 2-2 and T2-2  
<sup>3</sup>Carriage information:  
 1 = 1 driven carriage  
 2 = 1 driven and 1 passive carriage  
 3 = 1 driven and 2 passive carriages



### Technical information

| Basic Part Number | Life @ ¼ Design Load mm | Torque to Move Carriage Design Load Nm/kg | Carriage Design Load kg | Max Linear Speed mm/sec | Axial Load kg | Screw Inertia kgm <sup>2</sup> /m | Carriage Roll Angle Deg. |
|-------------------|-------------------------|---|-------------------------|-------------------------|---------------|-----------------------------------|--------------------------|
| RCMS23L-M08       | 254x10 <sup>6</sup>     | 0.038                                     | 46                      | 267                     | 14            | 3.9x10 <sup>-5</sup>              | 1                        |
| RCMS23L-0100      |                         | 0.020                                     |                         | 85                      |               |                                   |                          |
| RCMS23L-0200      |                         | 0.031                                     |                         | 169                     |               |                                   |                          |
| RCMS23L-0500      |                         | 0.047                                     |                         | 423                     |               |                                   |                          |
| RCMS23L-1000      |                         | 0.101                                     |                         | 847                     |               |                                   |                          |

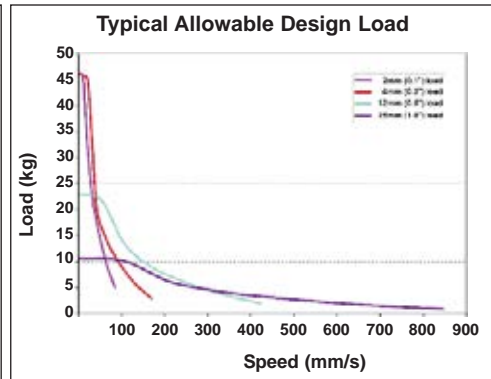
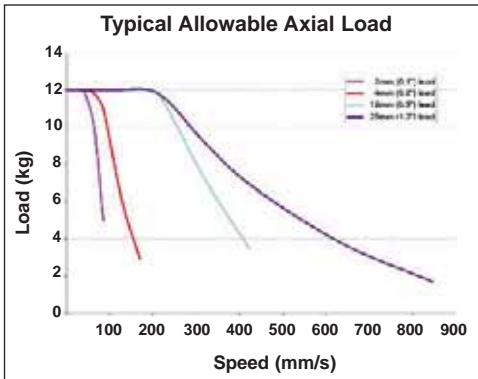

### Typical RCMS Accuracy Graph

Based on 0.500 inch lead with a 3 kg load Backlash <0.003 mm

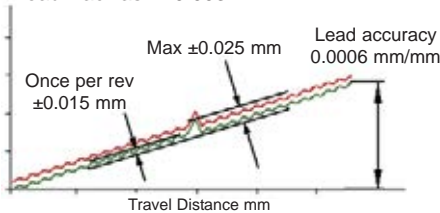

### ? Technical support

- Products overview - see pages 2-19 and 2-2
- Technical information - see pages T2-1 to T2-8

### i Product options

- Special carriage, rail, screw or metric mounting configurations
- Higher accuracy leadscrew
- Left Hand (LH) or Left/Right (L/R) thread
- Metric leads and guide lengths
- Alternative guide lengths
- Sensor kits, add -S to the end of the part number e.g. RCMS17L-M04-C-1-18-S

Intelligent Motors



## Hybrid linear actuators

Reliance offers a range of low maintenance hybrid linear actuators for equipment designers who require high performance and exceptional endurance in a very small package. The actuators are engineered with custom thermoplastics in the rotor drive nut and a stainless steel leadscrew. This allows the linear actuator to be quieter, more efficient and more durable than the standard acme thread and bronze nut configuration commonly used in other linear actuators.



The hybrid linear actuators are available in NEMA frame sizes 8 to 34, with up to 400 full steps per revolution and travel increments as small as 0.003 mm/step.

There are three configurations:

- captive shaft
- non-captive linear
- external linear

Captive linear actuators offer a short stroke in a compact package where anti-rotation of the shaft is not possible by any other means. These units convert rotary to linear motion via an integrated leadscrew and nut. The integrated leadscrew is held captive within the motor housing, welded to a stainless steel spline arrangement. This provides anti-rotation of the leadscrew enabling precise linear movement.

The non-captive linear actuator leadscrew travels through the motor giving an extremely short footprint. As with the captive shaft actuator, conversion of rotary to linear motion takes place within the motor itself by means of the integrated leadscrew and nut, therefore eliminating the use of belts and pulleys, couplings and other mechanical transmission components.



Size 8



Size 11 and  
Size 14



Size 17 and  
Size 23



Size 34

External linear actuators combine conventional leadscrew and nut technology with stepper motor technology. The leadscrew forms part of the motor shaft negating the need for a shaft to shaft coupling, thus providing zero transmission error from motor to screw and shortening the overall linear footprint.

Contact us for details of products and specifications.



## Can-Stack linear actuators



For volume applications we also offer Can-Stack linear actuators, which are a threaded rotor in conjunction with a leadscrew shaft to provide rapid linear movement in two directions (inward and outward). They are available in captive shaft, non-captive linear or external linear variants.

Unique features give ruggedness and reliability that assure long life and consistent performance. Rare earth magnets are available for even higher thrust. The actuators are built with dual ball bearings for greater motion control, precise step accuracy and long life.

Applications for the Can-Stack linear actuators include medical instrumentation, machinery automation, robotics and other automated devices which require precise, remote controlled linear movement in a broad range of temperature environments, whilst the hybrid linear actuators are ideal for applications requiring precise positioning, rapid motion and long life, including XY tables, medical equipment and semi-conductor handling equipment.



Micro dispensing syringe drive



Pharmaceutical testing equipment

## Customised configurations

In addition to standard configurations the actuators can be modified to meet specific application requirements. Reliance's applications engineering experience, manufacturing and assembly capabilities enable us to provide modified products and bespoke assembly solutions, see [page 2-18](#).







## Linear rail actuators

The linear rail actuator consists of a stationary base and load bearing carriage that travels along a rigid extruded aluminium rail, together with a single stack size 17 stepper motor.



The carriage design is unique; it controls slide bearing play with a self-adjusting linear bearing. Integrated along the entire length rail system are “T” slots allowing mounting of limit switches and sensors.

The leadscrew is made from 303 stainless steel with a Black Ice™ TFE coating for durable and permanent lubrication.

The features of the linear rail actuator include:

- “T” slots integrated into exterior rail bottom and sides that accommodate full length support and various mounting options
- Loads easily attach to the compact, moving carriage with four or six M4 x 0.7 size screws
- Load bearing carriage moves efficiently and smoothly within the internal rail geometry of this specially designed aluminum extrusion
- Rail provides end-to-end axial stability and precise motion system accuracy
- Automatic adjustments of slide bearing play with a patent pending “anti-backlash” linear bearing
- Rated life equals that of the existing leadscrews of similar size
- Leadscrew end configurations adapt to various rotary motion sources
- Black Ice™ TFE coatings on a 303 stainless steel leadscrew

For optimum performance, the system can be fitted with the Size 17 Hybrid Linear Actuator, see [page 2-24](#) available in a wide variety of resolutions - from 0.001524 mm/step to 0.048768 mm/step, delivering thrust of up to 222 N. For greater performance Size 17 Hybrid Double Stack Linear actuators provide 0.0158mm/step to 0.127 mm/step and deliver thrust of up to 337 N.

### Load ratings

|                        | RLRW04   |
|------------------------|----------|
| Top load (Z direction) | 225 N    |
| Overhang               | 225 N    |
| Moment roll            | 8.5 Nm   |
| Moment yaw             | 8.5 Nm   |
| Moment pitch           | 8.5 Nm   |
| Twist                  | ±0.75°/m |

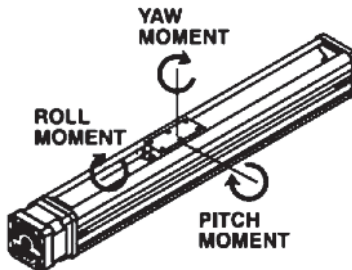



Associated Products  
Hardware: page 13-1

All dimensions in mm  
unless otherwise stated

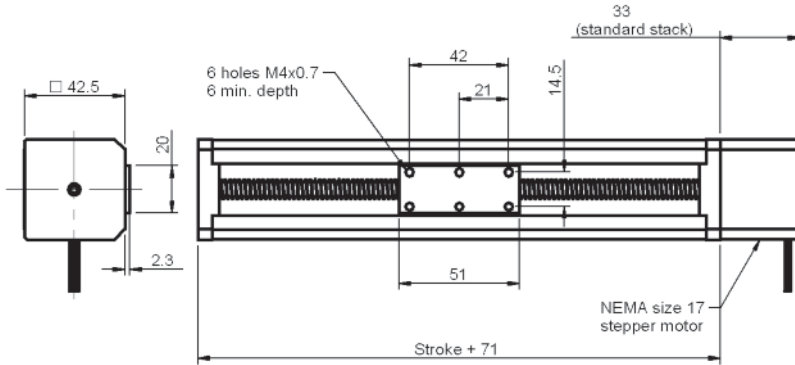

### Part number selection table

| Example Part No. <b>RLRW04 - B - R<sup>(2)</sup> - M<sup>(3)</sup> - 43<sup>(4)</sup> - 0025 - 12</b> |  |                            |                   |                               |             |           |             |  |
|---|--|----------------------------|-------------------|-------------------------------|-------------|-----------|-------------|--|
| Basic Part Number   | Screw Coating <sup>(1)</sup>   | Performance Specifications |                   |                               | Thread Code | Lead (mm) | Lead (inch) | Stroke <sup>(5)</sup> Rounded Up (inch)                |
|   |  | Max Stroke Length (mm)     | Max Speed (m/sec) | Straight Line Accuracy (mm/m) |             |           |             |  |
| RLRW04  | <b>B</b><br>(Black Ice™)<br><br><b>S</b><br>(Uncoated)<br><br><b>N</b><br>(No screw) | 1,000                      | 0.5               | ±1.0                          | 0025        | 0.635     | 0.025       | <b>07</b> = 7in<br><b>08</b> = 8in<br><b>12</b> = 12in |
|   |  |                            |                   |                               | 0031        | 0.794     | 0.03125     |  |
|   |  |                            |                   |                               | 0039        | 1.0       | 0.0394      |  |
|   |  |                            |                   |                               | 0050        | 1.27      | 0.05        |  |
|   |  |                            |                   |                               | 0063        | 1.588     | 0.0625      |  |
|   |  |                            |                   |                               | 0079        | 2.0       | 0.0787      |  |
|   |  |                            |                   |                               | 0100        | 2.54      | 0.1         |  |
|   |  |                            |                   |                               | 0125        | 3.175     | 0.125       |  |
|   |  |                            |                   |                               | 0197        | 5.0       | 0.1969      |  |
|   |  |                            |                   |                               | 0250        | 6.35      | 0.25        |  |
|   |  |                            |                   |                               | 0394        | 10.0      | 0.3937      |  |
|   |  |                            |                   |                               | 0500        | 12.70     | 0.5         |  |
| 0750  | 19.05  | 0.75                       |                   |                               |             |           |             |  |
| 1000  | 25.40  | 1.0                        |                   |                               |             |           |             |  |

<sup>(1)</sup> Alternative screw coatings available, please contact our sales team for more information

<sup>(2)</sup> R = right handed, L = left handed, N = no screw

<sup>(3)</sup> M = motorised

<sup>(4)</sup> Size 17 stepper motor

<sup>(5)</sup> Stroke length in inches and will be rounded up. Maximum length 24 inch

Intelligent Motors



## Introducing the motorised leadscrew linear slide range

Reliance offers a range of motorised actuator systems including the motorised leadscrew linear slide. It offers exceptional linear speed, accurate positioning, and long life in a compact assembly. One of its many advantages is that the length and speed are not limited by critical screw speed, allowing high RPM and linear speeds, even over long spans. Lengths up to 2.4 metres can readily be built, and longer lengths are possible on a special order basis.



The motorised leadscrew linear slide features wear-compensating, anti-backlash carriages to ensure repeatable and accurate positioning. The pre-assembled unit combines a screw-driven linear actuator with an integrated stepper motor drive reducing part count and improving system integration.

It is available in standard and wide base options, each capable of supporting a range of load capacities. There are four variants of the standard base supporting 67 N, 156 N, 222 N and 445 N, and two of the wide base to support 156 N and 445 N. Both are available with a right or left hand thread; the nominal thread leads are shown in the table opposite. The stepper motor is available in three sizes - NEMA size 11, 17 and 23, alternatively the actuator can be supplied integrated with the Reliance Cool Muscle motor, see [pages 2-19 to 2-23](#), or as a non-motorised leadscrew linear slide see [page 7-38](#).

Typical considerations when selecting a linear actuator include:

- How much force is required from the linear actuator?
- What is the duty cycle of the linear move?
- What is desired step increment from the linear actuator?
- What is the step rate or speed of travel?
- Bipolar or unipolar coils in the stepper motor prime mover?
- Stepper motor coil voltage?
- Must the lead screw hold position with power off or must it be "backdrivable" with power off?
- Are there size restrictions (max footprint of the linear actuator)?
- What is the anticipated life requirement?
- Temperature of operating environment?



Please contact us to discuss your requirements.



### Product selection table

| Nominal Thread Lead<br>Inches      mm |       | Standard Base Option                |  |                        |                        | Wide Base Option                                 |                        |
|---------------------------------------|-------|-------------------------------------|--|------------------------|------------------------|--|------------------------|
|                                       |       | Standard 1                          | Standard 2                                       | Standard 3             | Standard 4             | Wide 1   | Wide 2                 |
|                                       |       | 67 N                                | 156 N  | 222 N                  | 445 N                  | 156 N  | 445 N                  |
|                                       |       | Size 11DS<br>Size 17SS<br>Size 17DS | Size 17SS<br>Size 17DS<br>Size 23SS<br>Size 23DS | Size 23SS<br>Size 23DS | Size 23SS<br>Size 23DS | Size 17SS<br>Size 17DS<br>Size 23SS<br>Size 23DS | Size 23SS<br>Size 23DS |
| 0.025                                 | 0.635 | •                                   |  |                        |                        |  |                        |
| 0.039                                 | 1.00  | •                                   |  |                        |                        |  |                        |
| 0.050                                 | 1.27  | •                                   | •  |                        |                        | •  |                        |
| 0.0625                                | 1.59  | •                                   |  |                        |                        |  |                        |
| 0.079                                 | 2.00  | •                                   | •  |                        |                        | •  |                        |
| 0.098                                 | 2.50  |                                     |  | •                      |                        |  |                        |
| 0.100                                 | 2.54  | •                                   | •  | •                      | •                      | •  | •                      |
| 0.118                                 | 3.00  | •                                   |  |                        |                        |  |                        |
| 0.125                                 | 3.18  |                                     |  |                        | •                      |  | •                      |
| 0.157                                 | 4.00  |                                     | •  |                        |                        | •  |                        |
| 0.197                                 | 5.00  |                                     | •  | •                      |                        | •  |                        |
| 0.200                                 | 5.08  | •                                   | •  | •                      | •                      | •  | •                      |
| 0.250                                 | 6.35  | •                                   | •  |                        | •                      | •  | •                      |
| 0.315                                 | 8.00  |                                     |  |                        | •                      |  | •                      |
| 0.375                                 | 9.53  |                                     | •  |                        |                        | •  |                        |
| 0.394                                 | 10.00 | •                                   |  |                        |                        |  |                        |
| 0.400                                 | 10.16 |                                     | •  |                        |                        | •  |                        |
| 0.472                                 | 12.00 |                                     | •  |                        |                        | •  |                        |
| 0.500                                 | 12.70 | •                                   | •  | •                      | •                      | •  | •                      |
| 0.630                                 | 16.00 |                                     |  | •                      | •                      |  | •                      |
| 0.750                                 | 19.05 | •                                   | •  |                        |                        | •  |                        |
| 0.984                                 | 25.00 |                                     | •  |                        |                        | •  |                        |
| 1.000                                 | 25.40 |                                     | •  | •                      | •                      | •  | •                      |
| 1.200                                 | 30.48 |                                     | •  |                        |                        | •  |                        |
| 1.500                                 | 38.10 |                                     |  |                        | •                      |  | •                      |
| 2.000                                 | 50.80 |                                     |  |                        | •                      |  | •                      |

**Notes**

The wide base option provides parallel guide tracks for traversing sensor mount devices

SS = Single Stack, standard linear actuator stepper motor

DS = Double Stack, hybrid linear actuator stepper motor

For further information regarding the single and double stack motors, please contact us

Intelligent Motors



# Section Contents

- Gearbox Range - Overview .....Page 3-2
- Planetary Gearboxes - Overview.....Page 3-3
  - Section Views .....Page 3-4
  - RGP40 Series .....Page 3-6
  - RGP60 Series .....Page 3-10
  - RGN70 Series.....Page 3-12
- Bevel and Hypoid Gearboxes - Overview .....Page 3-14
  - Hypoid Gearboxes .....Page 3-16
  - Bevel Gearboxes .....Page 3-17
- Epicyclic Modules - Overview .....Page 3-24
  - Epicyclic Modules .....Page 3-26
  - Epicyclic Module Accessories .....Page 3-27
- Custom Gearboxes - Overview .....Page 3-28
- Technical Information.....Page T3-1

# Planetary and Right Angle Gearboxes



## Introduction to the range

Our standard product range includes planetary, bevel and hypoid gearboxes, which provide housed, modular solutions, as well as an epicyclic gear module, which can be used in single or multiple stacks to build a customised gearbox. We also provide design, manufacturing, assembly and test services to create custom gearbox solutions, designed to specification.

### Standard gearboxes



Planetary gearboxes



Bevel gearboxes



Epicyclic modules

Gearboxes

### Custom gearboxes



Custom-designed gearboxes



Concept development and prototype



Gearboxes for harsh environments





## Planetary gearboxes

Planetary gearboxes give the ability to increase the torque and lower the speed of an electric motor, such as a stepper motor, thereby transforming the power and improving control of an electro-mechanical system.

The Reliance planetary gearboxes offer low backlash, high torsional stiffness, and high levels of efficiency, suitable for industrial automation applications. They are ideally suited to working with the Reliance Cool Muscle intelligent servo system in high torque applications where positional feedback is important.

We offer 3 planetary gearboxes – the RGP40 and RGP60 provide a compact solution for integration with Reliance Cool Muscle, whilst the RGPN70 is for higher precision, higher stiffness, higher torque and lower backlash applications.



Reliance Cool Muscle servo system



RGP40 series



RGP60 series



Pharmaceutical testing equipment



Industrial automation

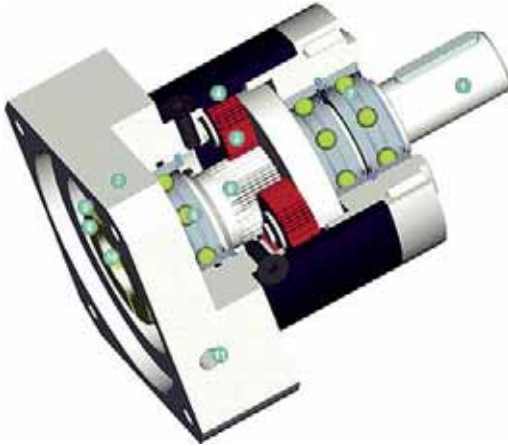

## RGP40, RGP60

- standard backlash (RGP40 from <math><22'</math>)  
(RGP60 from <math><18'</math>)
- high output torque
- novel motor clamp system
- high efficiency (up to 96%)
- ratios  $i=3, \dots, 512$
- low noise
- high quality
- any mounting position
- easy motor mounting
- lifetime lubrication
- direction of rotation equidirectional

- 1 Output shaft**  
High strength one piece planet carrier and output shaft
- 2 Output shaft bearing**  
Deep groove ball bearings with contact seals
- 3 Planet gear**  
Precision zero helix angle gear with optimised profile modifications and crowning, case hardened and hard finished by honing
- 4 Housing with integrated ring gear**  
Ring gear case hardened for high load capacity, minimum wear, consistent backlash
- 5 Sun gear**  
Precision machined optimised gear profile, case hardened and honed for higher load capacity, low noise, minimum wear and consistent backlash
- 6 Bearing for sun gear**  
High speed, deep groove ball bearings eliminating thrust loads from thermal expansion, whilst providing exact sun gear position for easy mounting
- 7 Motor adaptor plate**  
Allows matching up of the gear head with NEMA 17 and 23 motors, made from aluminium for enhanced thermal conductivity (other adaptors and motors on request)
- 8 Clamping ring**  
Balanced ring suitable for high rpm, made from steel to allow greater clamping forces for safe torque transfer
- 9 Clamping screw**  
High strength steel with special low pitch thread to generate a greater clamping force
- 10 Motor shaft clamp**  
Multiple closed slot precision clamping system for improved reliability
- 11 Assembly hole**  
Access hole for the clamping screw



### RGPN70

- low backlash (<math><5'</math>)
- high output torque
- novel motor clamp system
- high efficiency (up to 98%)
- honed gearing
- ratios  $i=3, \dots, 100$
- low noise (<math>< 58 \text{ dB}</math>)
- high quality
- any mounting position
- easy motor mounting
- lifetime lubrication
- direction of rotation equidirectional

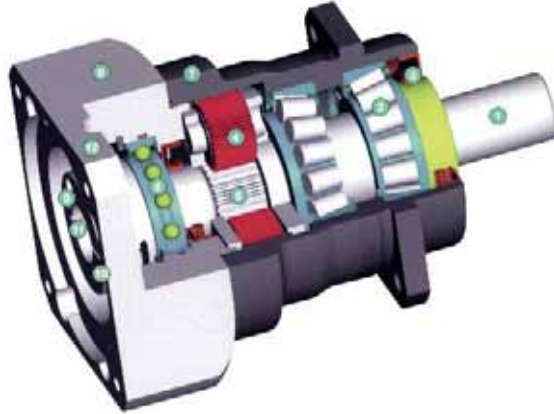

**1 Output shaft**

High strength, one piece planet carrier and output shaft

**2 Output shaft bearing**

High precision, preloaded taper roller bearings for zero clearance

**3 Sealing ring**

Dedicated double lip seal. The lubricant is kept in while contaminants remain outside the gearbox; IP65 rated

**4 Planet gear**

Precision zero helix angle gear with optimised profile modifications and crowning, case hardened and hard finished by honing

**5 Sun gear**

Precision machined optimised gear profile, case hardened and honed for higher load capacity, low noise, minimum wear and consistent backlash

**6 Bearing for sun gear**

High speed, deep groove ball bearings eliminating thrust loads from thermal expansion, whilst providing exact sun gear position for easy mounting

**7 Housing with integrated ring gear**

Ring gear case hardened for high load capacity, minimum wear, consistent backlash

**8 Motor adaptor plate**

Allows matching up of the gearhead with NEMA 23 motors, made from aluminium for enhanced thermal conductivity (other adaptors and motors on request)

**9 Clamping ring**

Balanced ring suitable for high rpm, made from steel to allow greater clamping forces for safe torque transfer

**10 Clamping screw**

High strength steel with special low pitch thread to generate a greater clamping force

**11 Motor shaft clamp**

Precision clamping system for improved reliability

**12 Assembly hole**

Access hole for the clamping screw



All dimensions in mm

**Associated Products**  
 Reliance Cool Muscle: page 2-2  
 Couplings: page 8-1  
 Hardware: page 13-1

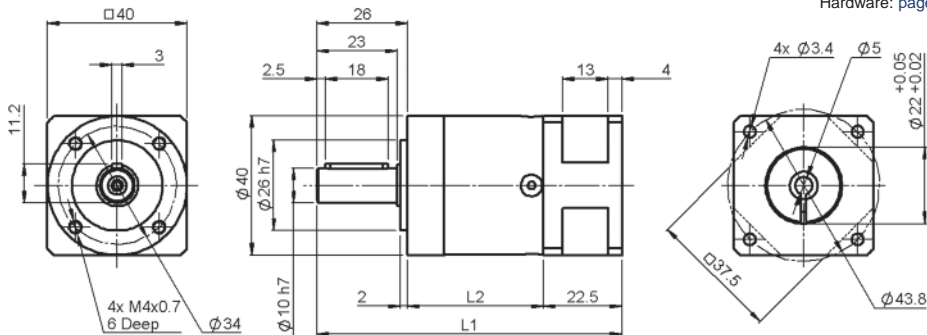

**Part number selection table**

Example Part No:- **RGP40 - 60 - NEMA17**

| Basic Part Number | Ratio | Stage | L1<br>mm | L2<br>mm | Output Torque                |           | Inertia<br>kgcm <sup>2</sup> | Efficiency <sup>(6)</sup><br>with full load<br>% |
|-------------------|-------|-------|----------|----------|------------------------------|-----------|------------------------------|--|
|                   |       |       |          |          | Nominal<br>Nm <sup>(2)</sup> | Max<br>Nm |                              |  |
|                   |       |       |          |          |                              |           |                              |  |
| RGP40             | 3     | 1     | 87.5     | 39       | 11                           | 17.6      | 0.031                        | 98   |
|                   | 4     |       |          |          | 15                           | 24        | 0.022                        | 98   |
|                   | 5     |       |          |          | 14                           | 22        | 0.019                        | 98   |
|                   | 7     |       |          |          | 8.5                          | 13.6      | 0.018                        | 97   |
|                   | 8     |       |          |          | 6                            | 10        | 0.017                        | 96   |
|                   | 10    |       |          |          | 5                            | 8         | 0.016                        | 95   |
| RGP40             | 9     | 2     | 100.5    | 52       | 16.5                         | 26        | 0.030                        | 97   |
|                   | 12    |       |          |          | 20                           | 32        | 0.029                        | 96   |
|                   | 15    |       |          |          | 18                           | 29        | 0.023                        | 96   |
|                   | 16    |       |          |          | 20                           | 32        | 0.022                        | 96   |
|                   | 20    |       |          |          | 20                           | 32        | 0.019                        | 96   |
|                   | 25    |       |          |          | 18                           | 29        | 0.019                        | 95   |
|                   | 32    |       |          |          | 20                           | 32        | 0.017                        | 95   |
|                   | 40    |       |          |          | 18                           | 29        | 0.016                        | 94   |
| RGP40             | 64    | 3     | 113      | 64.5     | 7.5                          | 12        | 0.016                        | 86   |
|                   | 60    |       |          |          | 20                           | 32        | 0.029                        | 92   |
|                   | 80    |       |          |          | 20                           | 32        | 0.019                        | 90   |
|                   | 100   |       |          |          | 20                           | 32        | 0.019                        | 89   |
|                   | 120   |       |          |          | 18                           | 29        | 0.029                        | 87   |
|                   | 160   |       |          |          | 20                           | 32        | 0.016                        | 86   |
|                   | 200   |       |          |          | 18                           | 29        | 0.016                        | 82   |
|                   | 256   |       |          |          | 20                           | 32        | 0.016                        | 81   |
|                   | 320   |       |          |          | 18                           | 29        | 0.016                        | 76   |
|                   | 512   |       |          |          | 7.5                          | 12        | 0.016                        | 48   |

Gearboxes



## Technical information

| Specification                                | Unit      | RGP40            | Stage |
|--|-----------|------------------|-------|
| <b>Backlash</b>                              | arcmin    | <15              | 1     |
|  |           | <19              | 2     |
|  |           | <22              | 3     |
| <b>Torsional stiffness</b>                   | Nm/arcmin | 1.0              | 1     |
|  |           | 1.1              | 2     |
|  |           | 1.0              | 3     |
| <b>Weight</b>                                | kg        | 0.35             | 1     |
|  |           | 0.45             | 2     |
|  |           | 0.55             | 3     |
| <b>Lifetime<sup>(3)</sup></b>                | h         | 30,000           |       |
| <b>Radial load for 20,000h<sup>(4)</sup></b> | N         | 200              |       |
| <b>Axial load for 20,000h<sup>(4)</sup></b>  | N         | 200              |       |
| <b>Running noise<sup>(5)</sup></b>           | dB(A)     | 58               |       |
| <b>Maximum input speed</b>                   | rpm       | 18,000           |       |
| <b>Input speed at &gt;50% torque</b>         |           | 5,000            |       |
| <b>Operating temperature</b>                 | max °C    | 90               |       |
|  | min °C    | -25              |       |
| <b>Motor mounting clamp torque</b>           | M2.5      | Nm               | 2     |
| <b>Lubrication</b>                           |           | Greased for life |       |
| <b>Degree of protection</b>                  |           | IP54             |       |

<sup>(1)</sup> Gearboxes for use with NEMA motors are supplied with a motor output shaft bush

<sup>(2)</sup> Emergency stop torque equals twice nominal torque, maximum 500 times

<sup>(3)</sup> Based on nominal torque and output shaft speed 100 rpm

<sup>(4)</sup> Based on output shaft speed 100 rpm, centrally positioned along shaft

<sup>(5)</sup> Distance 1 metre, idle running, input speed 3,000 rpm, ratio 5

<sup>(6)</sup> Degree of efficiency at nominal output torque, reference temperature 70°C at 1,000 rpm

## Technical support

- Product overview - see [page 3-3](#)
- Technical information - see [pages T3-1 to T3-3](#)
- Section view - see [page 3-4](#)
- For detailed duty cycle and life calculation, please contact us
- Gearbox complements the Reliance Cool Muscle servo system - see [page 2-2](#)
- For system design information when using the RGP40 series with Reliance Cool Muscle, please contact us

## Features and options

- Gearbox may be used in any mounting orientation
- Housing material: Steel - black
- Input and output flanges material: Aluminium - untreated
- Optional smooth output shaft if required
- Other motors may be utilised, please contact us





All dimensions in mm

**Associated Products**  
 Reliance Cool Muscle: page 2-2  
 Couplings: page 8-1  
 Hardware: page 13-1

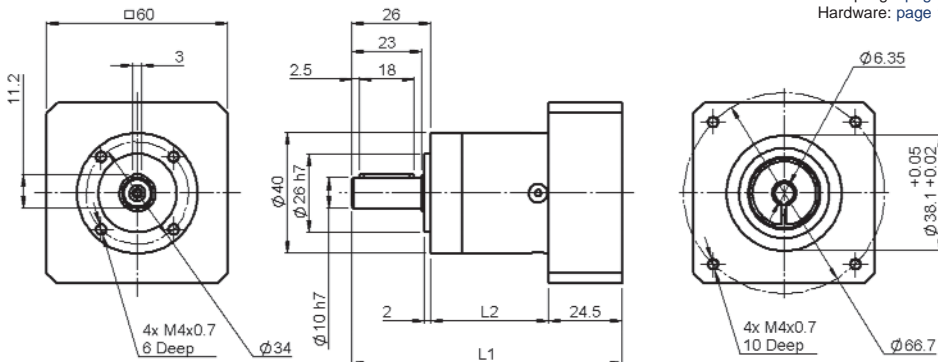

**Part number selection table**

Example Part No:- **RGP40 - 60 - NEMA23**

| Basic Part Number | Ratio | Stage | L1<br>mm | L2<br>mm | Output Torque                |           | Inertia<br>kgcm <sup>2</sup> | Efficiency <sup>(6)</sup><br>with full load<br>% |
|-------------------|-------|-------|----------|----------|------------------------------|-----------|------------------------------|--|
|                   |       |       |          |          | Nominal<br>Nm <sup>(2)</sup> | Max<br>Nm |                              |  |
|                   |       |       |          |          |                              |           |                              |  |
| RGP40             | 3     | 1     | 89.5     | 39       | 11                           | 17.6      | 0.031                        | 98   |
|                   | 4     |       |          |          | 15                           | 24        | 0.022                        | 98   |
|                   | 5     |       |          |          | 14                           | 22        | 0.019                        | 98   |
|                   | 7     |       |          |          | 8.5                          | 13.6      | 0.018                        | 97   |
|                   | 8     |       |          |          | 6                            | 10        | 0.017                        | 96   |
|                   | 10    |       |          |          | 5                            | 8         | 0.016                        | 95   |
| RGP40             | 9     | 2     | 102.5    | 52       | 16.5                         | 26        | 0.030                        | 97   |
|                   | 12    |       |          |          | 20                           | 32        | 0.029                        | 96   |
|                   | 15    |       |          |          | 18                           | 29        | 0.023                        | 96   |
|                   | 16    |       |          |          | 20                           | 32        | 0.022                        | 96   |
|                   | 20    |       |          |          | 20                           | 32        | 0.019                        | 96   |
|                   | 25    |       |          |          | 18                           | 29        | 0.019                        | 95   |
|                   | 32    |       |          |          | 20                           | 32        | 0.017                        | 95   |
|                   | 40    |       |          |          | 18                           | 29        | 0.016                        | 94   |
| RGP40             | 64    | 3     | 115      | 64.5     | 7.5                          | 12        | 0.016                        | 86   |
|                   | 60    |       |          |          | 20                           | 32        | 0.029                        | 92   |
|                   | 80    |       |          |          | 20                           | 32        | 0.019                        | 90   |
|                   | 100   |       |          |          | 20                           | 32        | 0.019                        | 89   |
|                   | 120   |       |          |          | 18                           | 29        | 0.029                        | 87   |
|                   | 160   |       |          |          | 20                           | 32        | 0.016                        | 86   |
|                   | 200   |       |          |          | 18                           | 29        | 0.016                        | 82   |
|                   | 256   |       |          |          | 20                           | 32        | 0.016                        | 81   |
|                   | 320   |       |          |          | 18                           | 29        | 0.016                        | 76   |
|                   | 512   |       |          |          | 7.5                          | 12        | 0.016                        | 48   |



## Technical information

| Specification                          | Unit             | RGP40  | Stage |
|--|------------------|--------|-------|
| Backlash                               | arcmin           | <15    | 1     |
|  |                  | <19    | 2     |
|  |                  | <22    | 3     |
| Torsional stiffness                    | Nm/arcmin        | 1.0    | 1     |
|  |                  | 1.1    | 2     |
|  |                  | 1.0    | 3     |
| Weight                                 | kg               | 0.35   | 1     |
|  |                  | 0.45   | 2     |
|  |                  | 0.55   | 3     |
| Lifetime <sup>(3)</sup>                | h                | 30,000 |       |
| Radial load for 20,000h <sup>(4)</sup> | N                | 200    |       |
| Axial load for 20,000h <sup>(4)</sup>  | N                | 200    |       |
| Running noise <sup>(5)</sup>           | dB(A)            | 58     |       |
| Maximum input speed                    | rpm              | 18,000 |       |
| Input speed at >50% torque             |                  | 5,000  |       |
| Operating temperature                  | max °C           | 90     |       |
|  | min °C           | -25    |       |
| Motor mounting clamp torque            | M2.5             | Nm     | 2     |
| Lubrication                            | Greased for life |        |       |
| Degree of protection                   | IP54             |        |       |

<sup>(1)</sup> Gearboxes for use with NEMA motors are supplied with a motor output shaft bush

<sup>(2)</sup> Emergency stop torque equals twice nominal torque, maximum 500 times

<sup>(3)</sup> Based on nominal torque and output shaft speed 100 rpm

<sup>(4)</sup> Based on output shaft speed 100 rpm, centrally positioned along shaft

<sup>(5)</sup> Distance 1 metre, idle running, input speed 3,000 rpm, ratio 5

<sup>(6)</sup> Degree of efficiency at nominal output torque, reference temperature 70°C at 1,000 rpm

## ? Technical support

- Product overview - see [page 3-3](#)
- Technical information - see [pages T3-1 to T3-3](#)
- Section view - see [page 3-4](#)
- For detailed duty cycle and life calculation, please contact us
- Gearbox complements the Reliance Cool Muscle servo system - see [page 2-2](#)
- For system design information when using the RGP40 series with Reliance Cool Muscle, please contact us

## i Features and options

- Gearbox may be used in any mounting orientation
- Housing material: Steel - black
- Input and output flanges material: Aluminium - untreated
- Optional smooth output shaft if required
- Other motors may be utilised, please contact us
- Available as a right angle gearbox, please contact us







All dimensions in mm

**Associated Products**  
 Reliance Cool Muscle: page 2-2  
 Couplings: page 8-1  
 Hardware: page 13-1

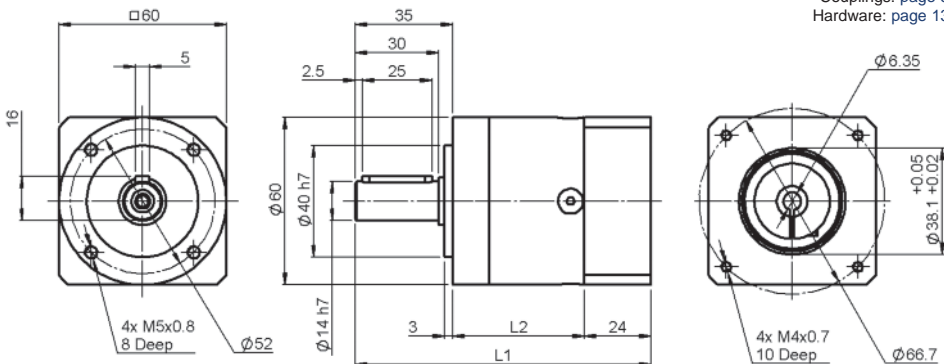

### Part number selection table

Example Part No:- **RG60 - 60 - NEMA23**

| Basic Part Number | Ratio | Stage | L1<br>mm | L2<br>mm | Output Torque                |           | Inertia<br>kgcm <sup>2</sup> | Efficiency <sup>(6)</sup><br>with full load<br>% |
|-------------------|-------|-------|----------|----------|------------------------------|-----------|------------------------------|--|
|                   |       |       |          |          | Nominal<br>Nm <sup>(2)</sup> | Max<br>Nm |                              |  |
|                   |       |       |          |          |                              |           |                              |  |
| RGP60             | 3     | 1     | 106      | 47       | 28                           | 45        | 0.135                        | 98   |
|                   | 4     |       |          |          | 38                           | 61        | 0.093                        | 98   |
|                   | 5     |       |          |          | 40                           | 64        | 0.078                        | 98   |
|                   | 7     |       |          |          | 25                           | 40        | 0.072                        | 97   |
|                   | 8     |       |          |          | 18                           | 29        | 0.065                        | 97   |
|                   | 10    |       |          |          | 15                           | 24        | 0.064                        | 96   |
| RGP60             | 9     | 2     | 118.5    | 59.5     | 44                           | 70        | 0.131                        | 97   |
|                   | 12    |       |          |          | 44                           | 70        | 0.127                        | 96   |
|                   | 15    |       |          |          | 44                           | 70        | 0.077                        | 96   |
|                   | 16    |       |          |          | 44                           | 70        | 0.088                        | 96   |
|                   | 20    |       |          |          | 44                           | 70        | 0.075                        | 96   |
|                   | 25    |       |          |          | 40                           | 64        | 0.075                        | 95   |
|                   | 32    |       |          |          | 44                           | 70        | 0.064                        | 95   |
|                   | 40    |       |          |          | 40                           | 64        | 0.064                        | 94   |
| RGP60             | 64    | 3     | 131      | 72       | 18                           | 29        | 0.064                        | 87   |
|                   | 60    |       |          |          | 44                           | 70        | 0.076                        | 92   |
|                   | 80    |       |          |          | 44                           | 70        | 0.075                        | 91   |
|                   | 100   |       |          |          | 44                           | 70        | 0.075                        | 89   |
|                   | 120   |       |          |          | 44                           | 70        | 0.064                        | 88   |
|                   | 160   |       |          |          | 44                           | 70        | 0.064                        | 86   |
|                   | 200   |       |          |          | 40                           | 64        | 0.064                        | 83   |
|                   | 256   |       |          |          | 44                           | 70        | 0.064                        | 81   |
|                   | 320   |       |          |          | 40                           | 64        | 0.064                        | 77   |
|                   | 512   |       |          |          | 18                           | 29        | 0.064                        | 51   |



## Technical information

| Specification                                | Unit      | RGP60            | Stage |
|--|-----------|------------------|-------|
| <b>Backlash</b>                              | arcmin    | <12              | 1     |
|  |           | <15              | 2     |
|  |           | <18              | 3     |
| <b>Torsional stiffness</b>                   | Nm/arcmin | 2.3              | 1     |
|  |           | 2.5              | 2     |
|  |           | 2.5              | 3     |
| <b>Weight</b>                                | kg        | 0.9              | 1     |
|  |           | 1.1              | 2     |
|  |           | 1.3              | 3     |
| <b>Lifetime<sup>(3)</sup></b>                | h         | 30,000           |       |
| <b>Radial load for 20,000h<sup>(4)</sup></b> | N         | 400              |       |
| <b>Axial load for 20,000h<sup>(4)</sup></b>  | N         | 500              |       |
| <b>Running noise<sup>(5)</sup></b>           | dB(A)     | 58               |       |
| <b>Maximum input speed</b>                   | rpm       | 13,000           |       |
| <b>Input speed at &gt;50% Torque</b>         |           | 4,500            |       |
| <b>Operating temperature</b>                 | max °C    | 90               |       |
|  | min °C    | -25              |       |
| <b>Motor mounting clamp torque</b>           | M3        | Nm               | 4.5   |
| <b>Lubrication</b>                           |           | Greased for life |       |
| <b>Degree of protection</b>                  |           | IP54             |       |

<sup>(1)</sup> Gearboxes for use with NEMA motors are supplied with a motor output shaft bush

<sup>(2)</sup> Emergency stop torque equals twice nominal torque, maximum 500 times

<sup>(3)</sup> Based on nominal torque and output shaft speed 100 rpm

<sup>(4)</sup> Based on output shaft speed 100 rpm, centrally positioned along shaft

<sup>(5)</sup> Distance 1 metre, idle running, input speed 3,000 rpm, ratio 5

<sup>(6)</sup> Degree of efficiency at nominal output torque, reference temperature 70°C at 1,000 rpm

## Technical support

- Product overview - see [page 3-3](#)
- Technical information - see [pages T3-1 to T3-3](#)
- Section view - see [page 3-4](#)
- For detailed duty cycle and life calculation, please contact us
- Gearbox complements the Reliance Cool Muscle servo system - see [page 2-2](#)
- For system design information when using the RGP60 series with Reliance Cool Muscle, please contact us

## Features and options

- Gearbox may be used in any mounting orientation
- Housing material: Steel - black
- Input and output flanges material: Aluminium - untreated
- Optional smooth output shaft if required
- Other motors may be utilised, please contact us
- Available as a right angle gearbox, please contact us





All dimensions in mm

**Associated Products**  
 Reliance Cool Muscle: page 2-2  
 Couplings: page 8-1  
 Hardware: page 13-1

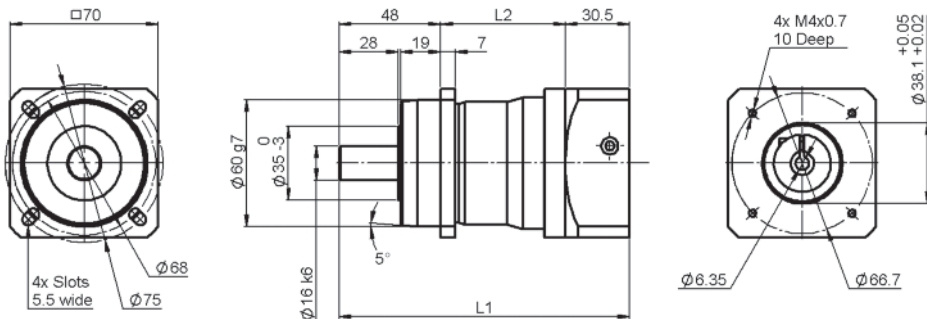

See page 3-10 for motor mount details

## Part number selection table

Example Part No:- **RGPN70 - 40 - NEMA23**

| Basic Part Number | Ratio | Stage | L1<br>mm | L2<br>mm | Output Torque                |           | Inertia<br>kgcm <sup>2</sup> | Input Speed at<br>50% Torque<br>rpm | Input Speed at<br>100% Torque<br>rpm |
|-------------------|-------|-------|----------|----------|------------------------------|-----------|------------------------------|-------------------------------------|--------------------------------------|
|                   |       |       |          |          | Nominal<br>Nm <sup>(2)</sup> | Max<br>Nm |                              |                                     |                                      |
| RGPN70            | 3     | 1     | 137.5    | 59       | 45                           | 72        | 0.40                         | 1,900                               | 1,650                                |
|                   | 4     |       |          |          | 60                           | 96        | 0.32                         | 2,200                               | 1,800                                |
|                   | 5     |       |          |          | 65                           | 104       | 0.28                         | 2,500                               | 2,000                                |
|                   | 7     |       |          |          | 45                           | 72        | 0.26                         | 3,200                               | 2,800                                |
|                   | 8     |       |          |          | 40                           | 64        | 0.25                         | 3,500                               | 3,100                                |
|                   | 10    |       |          |          | 27                           | 43        | 0.25                         | 4,000                               | 3,700                                |
| RGPN70            | 12    | 2     | 166.5    | 88       | 68                           | 109       | 0.40                         | 3,350                               | 2,750                                |
|                   | 15    |       |          |          | 68                           | 109       | 0.38                         | 3,800                               | 3,150                                |
|                   | 16    |       |          |          | 77                           | 123       | 0.35                         | 3,600                               | 3,000                                |
|                   | 20    |       |          |          | 77                           | 123       | 0.33                         | 4,000                               | 3,350                                |
|                   | 25    |       |          |          | 65                           | 104       | 0.30                         | 4,400                               | 3,800                                |
|                   | 32    |       |          |          | 77                           | 123       | 0.32                         | 4,500                               | 4,200                                |
|                   | 40    |       |          |          | 65                           | 104       | 0.29                         | 4,500                               | 4,500                                |
|                   | 64    |       |          |          | 40                           | 64        | 0.26                         | 4,500                               | 4,500                                |
|                   | 100   |       |          |          | 27                           | 43        | 0.25                         | 4,500                               | 4,500                                |



## Technical information

| Specification                                | Unit      | RGPN70           | Stage |
|--|-----------|------------------|-------|
| <b>Backlash</b>                              | arcmin    | <3               | 1     |
|  |           | <5               | 2     |
| <b>Torsional stiffness</b>                   | Nm/arcmin | 6                | 1     |
|  |           | 7                | 2     |
| <b>Efficiency with full load</b>             | %         | 98               | 1     |
|  |           | 95               | 2     |
| <b>Weight</b>                                | kg        | 1.9              | 1     |
|  |           | 2.4              | 2     |
| <b>Lifetime<sup>(3)</sup></b>                | h         | 20,000           |       |
| <b>Radial load for 20,000h<sup>(4)</sup></b> | N         | 3,200            |       |
| <b>Axial load for 20,000h<sup>(4)</sup></b>  | N         | 4,400            |       |
| <b>Running noise<sup>(5)</sup></b>           | dB(A)     | 58               |       |
| <b>Maximum input speed</b>                   | rpm       | 14,000           |       |
| <b>Operating temperature</b>                 | max °C    | 90               |       |
|  | min °C    | -25              |       |
| <b>Motor mounting clamp torque</b>           | M3        | Nm               | 4.5   |
|  | M4        |                  | 9.5   |
| <b>Lubrication</b>                           |           | Greased for life |       |
| <b>Degree of protection</b>                  |           | IP65             |       |

<sup>(1)</sup> Gearboxes for use with NEMA motors are supplied with a motor output shaft bush

<sup>(2)</sup> Emergency stop torque equals twice nominal torque, maximum 500 times

<sup>(3)</sup> Based on nominal torque and output shaft speed 100 rpm

<sup>(4)</sup> Based on output shaft speed 100 rpm, centrally positioned along shaft

<sup>(5)</sup> Distance 1 metre, idle running, input speed 3,000 rpm, ratio 5

### Technical support

- Product overview - see [page 3-3](#)
- Technical information - see [pages T3-1 to T3-3](#)
- Section view - see [page 3-5](#)
- For detailed duty cycle and life calculation, please contact us
- Gearbox complements the Reliance Cool Muscle servo system - see [page 2-2](#)
- For system design information when using the RGPN70 series with Reliance Cool Muscle, please contact us

### Features and options

- Gearbox may be used in any mounting orientation
- Housing material: Steel - black
- Input and output flanges material: Aluminium - untreated
- Optional keyway output shaft if required
- Other motors may be utilised, please contact us
- Available as a right angle gearbox, please contact us





## Economic, space saving solutions

The Reliance bevel and hypoid gearboxes provide an economic, space saving solution for right angle motion in a restricted space envelope. There are 3 types of gearbox available:



### The BE series

The BE series is the most economical choice, offered with stainless steel bevel gears mounted in plain bearings, with either 1:1 or 2:1 ratios. It is a small, compact, anodised aluminium unit, with a removable, plastic, clip-on cover. The unit can be easily mounted into an assembly to provide a 90° drive where space prevents a direct layout.



### The BS series

The BS series is a one-piece, slim-line aluminium housing with stainless steel bevel gears and shafting, offered in single or double output configurations with either 1:1 or 2:1 ratios. Using ISO 8 quality bevel gears, when assembled the backlash of the assembly is as low as <math><20</math> arcmins. It has a completely sealed casing providing a dust free and safe operation, with pre-tapped holes for alternative easy mounting. It is lubricated with high quality grease before sealing, providing lifetime lubrication and low maintenance.



### The HY series

The BS and BE series bevel gearboxes are suited to low-load industrial applications. For higher ratio requirements, between 5:1 and 10:1, we offer the HY series hypoid gearbox, also with a fully sealed aluminium housing and carbon steel gears and shafting. The hypoid gear pass allows for a high torque transmission coupled with a high ratio all within a compact package. Mounted in ball bearings the unit is fully lubricated and sealed for life. The variation of mounting holes allows the gearbox to be mounted on any face for greater assembly flexibility.



### The BE series

Pictured without its removable cover, the BE series gearbox shown with Reli-a-Flex™ couplings, leadscrew and Reliance Cool Muscle motor in a typical right angled drive system.



### The BS series

A single input, dual output BS series gearbox shown with Reli-a-Flex™ couplings, leadscrews and Reliance Cool Muscle motor.



### Part number structure

**BE 70 L - 002 B**

| Gearbox Type   | Overall Length                       | Gearbox Shape                                 | Gear Ratio  | Shaft Diameter Identification   |
|--|--------------------------------------|---|---|---|
| HY - Hypoid Gearbox<br>BS - Bevel Gearbox<br>BSB - Bevel Gearbox<br>BSH - Bevel Gearbox<br>BE - Bevel Gear Set | Distance from back face to shaft end | R = Rectangular<br>L = L shape<br>T = T shape | 001 = 1:1<br>002 = 2:1<br>005 = 5:1<br>010 = 10:1 | A = Smaller output/input shaft option<br>B = Larger output/input shaft option |



All dimensions in mm

Materials:

Body - Anodised aluminium  
(ISO AlMg0.7Si, AlMg1SiCu)

Pinion shaft - SCM435

Gear shaft - S45C

**Associated Products**

Motors: page 2-1

Couplings: page 8-1

Hardware: page 13-1

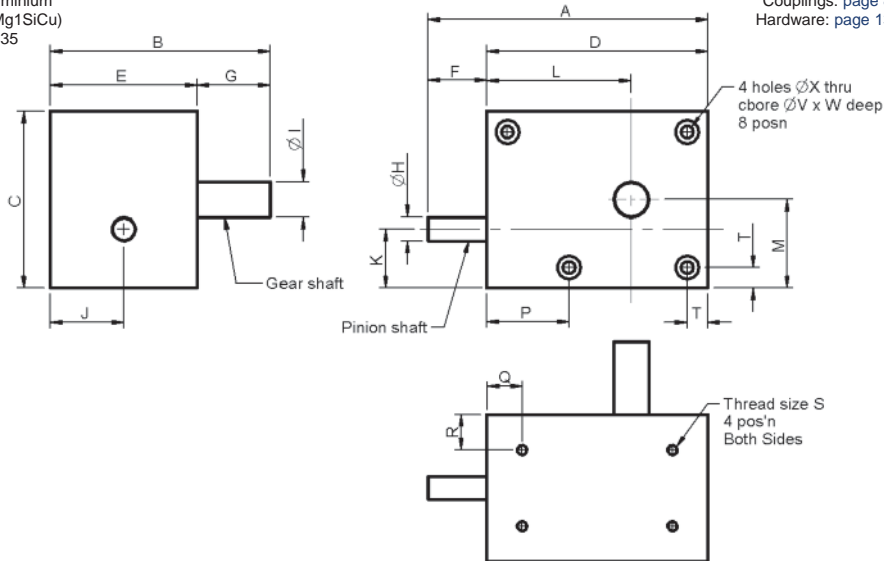

## Part number selection table

| Part Number | Gear Ratio | A   | B  | C  | D   | E  | F  | G  | ØH (h7) | ØI (h7) | J    | K    | L  | M    | T  | P  | Q  | R  |
|-------------|------------|-----|----|----|-----|----|----|----|---------|---------|------|------|----|------|----|----|----|----|
| HY70R-005   | 5          | 70  | 58 | 45 | 55  | 40 | 15 | 18 | 6       | 8       | 20.0 | 17.5 | 36 | 22.5 | 5  | 14 | 10 | 10 |
| HY90R-010   | 10         | 90  | 68 | 60 | 75  | 50 | 15 | 18 | 6       | 8       | 25.0 | 20.0 | 47 | 30.0 | 7  | 26 | 12 | 12 |
| HY95R-005   | 5          | 95  | 75 | 60 | 75  | 50 | 20 | 25 | 8       | 12      | 25.0 | 20.0 | 49 | 30.0 | 7  | 28 | 12 | 12 |
| HY120R-010  | 10         | 120 | 80 | 80 | 100 | 55 | 20 | 25 | 8       | 12      | 27.5 | 25.0 | 62 | 40.0 | 10 | 27 | 15 | 12 |

| Part Number | Hole Dims |       | Drilled Holes & C/Bores |                 |                | Maximum Overhang Load (N) | Weight (kg) |
|-------------|-----------|-------|-------------------------|-----------------|----------------|---------------------------|-------------|
|             | S         | Depth | Drill Hole ØX           | Counter Bore ØV | C/Bore Depth W |                           |             |
| HY70R-005   | M3        | 5     | 3.2                     | 6.5             | 3.2            | 19                        | 0.3         |
| HY90R-010   | M4        | 6     | 4.2                     | 8.0             | 4.3            | 19                        | 0.6         |
| HY95R-005   | M4        | 6     | 4.2                     | 8.0             | 4.3            | 39                        | 0.7         |
| HY120R-010  | M5        | 8     | 5.2                     | 9.5             | 5.3            | 39                        | 1.3         |

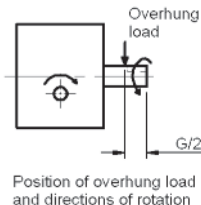

## Allowable rated torque table

| Part Number | Module | Teeth | Input Torque Ncm at: |        |        |        |         |         |         |         |
|-------------|--------|-------|----------------------|--------|--------|--------|---------|---------|---------|---------|
|             |        |       | 100rpm               | 250rpm | 500rpm | 800rpm | 1000rpm | 1500rpm | 2000rpm | 2500rpm |
| HY70R-005   | 0.75   | 8/40  | 76.0                 | 71.8   | 66.0   | 59.0   | 53.9    | 44.2    | 36.6    | 28.4    |
| HY90R-010   | 0.71   | 7/70  | 75.8                 | 70.8   | 63.8   | 56.0   | 50.7    | 41.3    | 34.3    | 27.3    |
| HY95R-005   | 1.1    | 8/40  | 247.4                | 232.1  | 211.8  | 187.7  | 170.3   | 137.7   | 112.6   | 86.0    |
| HY120R-010  | 1.0    | 7/70  | 186.3                | 172.7  | 155.7  | 136.6  | 123.5   | 100.0   | 82.7    | 65.0    |





**Associated Products**  
Motors: page 2-1  
Couplings: page 8-1  
Hardware: page 13-1

All dimensions in mm  
Materials:  
Body - Anodised aluminium  
(ISO AlMg0.7Si, AlMg1SiCu)  
Shaft - Stainless steel (SUS303)

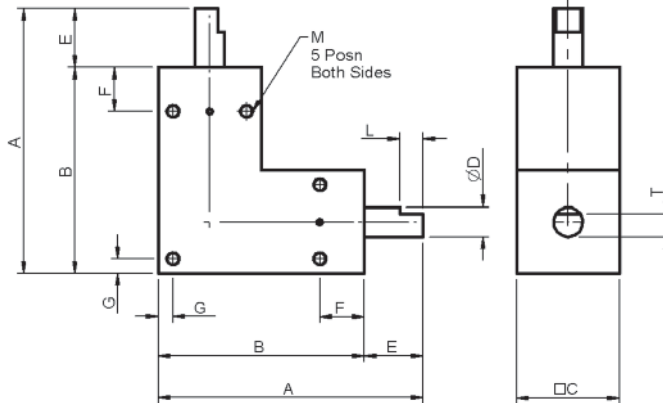

### Part number selection table

| Part Number | Gear Ratio | C  | A   | B  | ØD (h7) | E  | F  | G   | Shaft End |   | Hole Dims |       | Backlash (arcmin) | Weight (g) |
|-------------|------------|----|-----|----|---------|----|----|-----|-----------|---|-----------|-------|-------------------|------------|
|             |            |    |     |    |         |    |    |     | T         | L | M         | Depth |                   |            |
| BS35L-001   | 1          | 14 | 35  | 27 | 3       | 8  | 4  | 2   | 2.7       | 5 | M2        | 4     | 20                | 27         |
| BS45L-001   |            | 18 | 45  | 33 | 4       | 12 | 5  | 3   | 3.3       | 8 | M3        | 4     | 15                | 55         |
| BS65L-001   |            | 25 | 65  | 50 | 6       | 15 | 12 | 3.5 | -         | - | M4        | 6     | 15                | 175        |
| BS80L-001   |            | 30 | 80  | 60 | 8       | 20 | 15 | 5   | -         | - | M5        | 6     | 15                | 290        |
| BS90L-001   |            | 35 | 90  | 70 | 10      | 20 | 15 | 5   | -         | - | M5        | 7     | 15                | 496        |
| BS105L-001  |            | 40 | 105 | 80 | 12      | 25 | 20 | 5   | -         | - | M6        | 7     | 15                | 725        |
| BS65L-002   | 2          | 25 | 65  | 50 | 6       | 15 | 12 | 3.5 | -         | - | M4        | 6     | 15                | 175        |
| BS80L-002   |            | 30 | 80  | 60 | 8       | 20 | 15 | 5   | -         | - | M5        | 6     |                   | 290        |
| BS90L-002   |            | 35 | 90  | 70 | 10      | 20 | 15 | 5   | -         | - | M5        | 7     |                   | 496        |
| BS105L-002  |            | 40 | 105 | 80 | 12      | 25 | 20 | 5   | -         | - | M6        | 7     |                   | 725        |

### Allowable rated torque table

| Part Number | Module | Teeth | Input Torque Ncm at: |        |        |        |        |         |         |         |
|-------------|--------|-------|----------------------|--------|--------|--------|--------|---------|---------|---------|
|             |        |       | 50rpm                | 100rpm | 250rpm | 500rpm | 800rpm | 1000rpm | 1500rpm | 2000rpm |
| BS35L-001   | 0.4    | 20    | 7.1                  | 7.0    | 6.8    | 6.5    | 6.2    | 6.0     | 5.5     | 5.3     |
| BS45L-001   | 0.5    |       | 18.7                 | 18.6   | 18.1   | 17.3   | 16.5   | 16.0    | 15.0    | 14.0    |
| BS65L-001   | 0.8    |       | 73.7                 | 72.6   | 69.8   | 65.6   | 61.0   | 58.4    | 52.6    | 47.9    |
| BS80L-001   | 1.0    |       | 137.9                | 135.6  | 129.1  | 119.5  | 109.7  | 104.0   | 92.0    | 82.6    |
| BS90L-001   | 1.25   |       | 271.8                | 266.1  | 250.4  | 228.0  | 205.8  | 193.3   | 167.8   | 148.2   |
| BS105L-001  | 1.5    |       | 442.6                | 431.6  | 401.6  | 360.0  | 320.1  | 298.1   | 254.3   | 221.9   |
| BS65L-002   | 0.6    | 14/28 | 20.2                 | 20.1   | 19.7   | 19.0   | 18.3   | 17.8    | 16.7    | 15.7    |
| BS80L-002   | 0.8    | 13/26 | 39.8                 | 39.5   | 38.4   | 36.8   | 35.1   | 34.0    | 31.5    | 29.5    |
| BS90L-002   | 1.0    | 13/26 | 77.6                 | 76.7   | 74.3   | 70.5   | 66.4   | 64.0    | 58.6    | 54.4    |
| BS105L-002  | 1.25   | 13/26 | 141.5                | 139.6  | 134.0  | 125.7  | 116.9  | 111.7   | 100.7   | 91.5    |

Gearboxes



All dimensions in mm

Material:

Body - Anodised aluminium  
(ISO AlMg0.7Si, AlMg1SiCu)

Shaft - Stainless steel (SUS303)

**Associated Products**

Motors: page 2-1

Couplings: page 8-1

Hardware: page 13-1

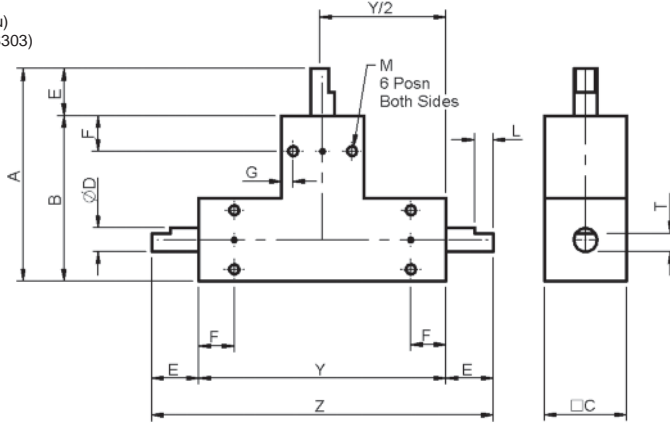

## Part number selection table

| Part Number | Gear Ratio | Z   | Y   | C  | A  | B  | ØD (h7) | E  | F  | G   | Shaft End |   | Set Screw |       | Backlash (arcmin) | Weight (g) |
|-------------|------------|-----|-----|----|----|----|---------|----|----|-----|-----------|---|-----------|-------|-------------------|------------|
|             |            |     |     |    |    |    |         |    |    |     | T         | L | M         | Depth |                   |            |
| BS45T-001   | 1          | 72  | 48  | 18 | 45 | 33 | 4       | 12 | 5  | 3.0 | 3.3       | 8 | M3        | 4     | 15                | 75         |
| BS65T-001   |            | 105 | 75  | 25 | 65 | 50 | 6       | 15 | 12 | 3.5 | -         | - | M4        | 6     |                   | 246        |
| BS80T-001   |            | 130 | 90  | 30 | 80 | 60 | 8       | 20 | 15 | 5.0 | -         | - | M5        | 6     |                   | 410        |
| BS90T-001   |            | 145 | 105 | 35 | 90 | 70 | 10      | 20 | 15 | 5.0 | -         | - | M5        | 7     |                   | 679        |
| BS65T-002   | 2          | 105 | 75  | 25 | 65 | 50 | 6       | 15 | 12 | 3.5 | -         | - | M4        | 6     | 15                | 246        |
| BS80T-002   |            | 130 | 90  | 30 | 80 | 60 | 8       | 20 | 15 | 5.0 | -         | - | M5        | 6     |                   | 410        |
| BS90T-002   |            | 145 | 105 | 35 | 90 | 70 | 10      | 20 | 15 | 5.0 | -         | - | M5        | 7     |                   | 679        |

## Allowable rated torque table

| Part Number | Module | Teeth | Input Torque Ncm at: |        |        |        |        |         |         |         |
|-------------|--------|-------|----------------------|--------|--------|--------|--------|---------|---------|---------|
|             |        |       | 50rpm                | 100rpm | 250rpm | 500rpm | 800rpm | 1000rpm | 1500rpm | 2000rpm |
| BS45T-001   | 0.5    | 20    | 18.7                 | 18.6   | 18.1   | 17.3   | 16.5   | 16.0    | 15.0    | 14.0    |
| BS65T-001   | 0.8    |       | 73.7                 | 72.6   | 69.8   | 65.6   | 61.0   | 58.4    | 52.6    | 47.9    |
| BS80T-001   | 1.0    |       | 137.9                | 135.6  | 129.1  | 119.5  | 109.7  | 104.0   | 92.0    | 82.6    |
| BS90T-001   | 1.25   |       | 271.8                | 266.1  | 250.4  | 228.0  | 205.8  | 193.3   | 167.8   | 148.2   |
| BS65T-002   | 0.6    | 14/28 | 20.2                 | 20.1   | 19.7   | 19.0   | 18.3   | 17.8    | 16.7    | 15.7    |
| BS80T-002   | 0.8    | 13/26 | 39.8                 | 39.5   | 38.4   | 36.8   | 35.1   | 34.0    | 31.5    | 29.5    |
| BS90T-002   | 1.0    | 13/26 | 77.6                 | 76.7   | 74.3   | 70.5   | 66.4   | 64.0    | 58.6    | 54.0    |

## Features and options

- Product overview - see page 3-14



### Associated Products

Motors: page 2-1  
Couplings: page 8-1  
Hardware: page 13-1

All dimensions in mm

Material:

Body - Anodised aluminium  
(ISO AlMg0.7Si, AlMg1SiCu)  
Shaft - Stainless steel (SUS303)

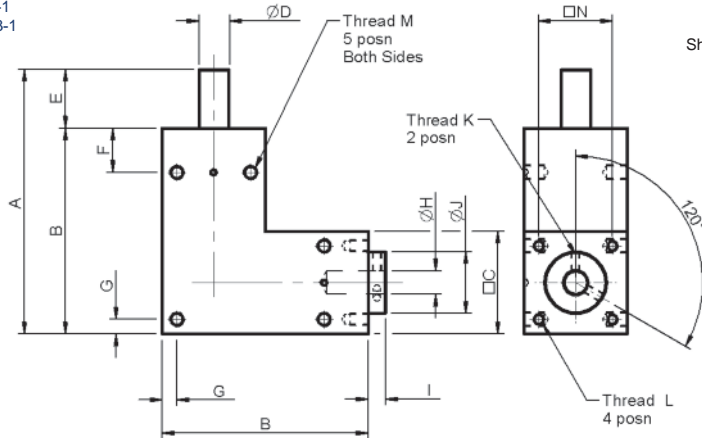

### Part number selection table

| Part Number  | Gear Ratio | C  | A   | B  | Bore |         |       | E  | I | ØJ | K  | F  | G   | M  | Depth | Set Screw |    | Weight (g) |
|--------------|------------|----|-----|----|------|---------|-------|----|---|----|----|----|-----|----|-------|-----------|----|------------|
|              |            |    |     |    | ØD   | ØH (H7) | Depth |    |   |    |    |    |     |    |       | L         | N  |            |
| BSB65L-001A  | 1          | 25 | 65  | 50 | 6    | 5       | 15    | 15 | 5 | 16 | M3 | 12 | 3.5 | M4 | 6     | M3        | 19 | 169        |
| BSB65L-001B  |            | 25 | 65  | 50 | 6    | 6       | 15    | 15 | 5 | 16 | M3 | 12 | 3.5 | M4 | 6     | M3        | 19 | 167        |
| BSB80L-001A  |            | 30 | 80  | 60 | 8    | 6       | 19    | 20 | 5 | 19 | M3 | 15 | 5   | M5 | 6     | M3        | 23 | 293        |
| BSB80L-001B  |            | 30 | 80  | 60 | 8    | 8       | 19    | 20 | 5 | 19 | M3 | 15 | 5   | M5 | 6     | M3        | 23 | 289        |
| BSB90L-001A  |            | 35 | 90  | 70 | 10   | 8       | 19    | 20 | 6 | 21 | M4 | 15 | 5   | M5 | 7     | M4        | 25 | 465        |
| BSB90L-001B  |            | 35 | 90  | 70 | 10   | 10      | 19    | 20 | 6 | 21 | M4 | 15 | 5   | M5 | 7     | M4        | 25 | 460        |
| BSB105L-001A |            | 40 | 105 | 80 | 12   | 10      | 23    | 25 | 6 | 26 | M4 | 20 | 5   | M6 | 7     | M4        | 30 | 722        |
| BSB105L-001B |            | 40 | 105 | 80 | 12   | 12      | 23    | 25 | 6 | 26 | M4 | 20 | 5   | M6 | 7     | M4        | 30 | 713        |

Backlash: 15 arcmin

### Allowable rated torque table

| Part Number    | Module | Teeth | Input Torque Ncm at: |        |        |        |        |         |         |         |
|----------------|--------|-------|----------------------|--------|--------|--------|--------|---------|---------|---------|
|                |        |       | 50rpm                | 100rpm | 250rpm | 500rpm | 800rpm | 1000rpm | 1500rpm | 2000rpm |
| BSB65L-001A/B  | 0.8    | 20    | 73.7                 | 72.6   | 69.8   | 65.6   | 61.0   | 58.4    | 52.6    | 47.9    |
| BSB80L-001A/B  | 1.0    |       | 137.9                | 135.6  | 129.1  | 119.5  | 109.7  | 104.0   | 92.0    | 82.6    |
| BSB90L-001A/B  | 1.25   |       | 271.8                | 266.1  | 250.4  | 228.0  | 205.8  | 193.3   | 167.8   | 148.2   |
| BSB105L-001A/B | 1.5    |       | 442.6                | 431.6  | 401.6  | 360.0  | 320.1  | 298.1   | 254.3   | 221.9   |

### Features and options

- Product overview - see page 3-14



All dimensions in mm

Material:

Body - Aluminium (ISO AlMg0.7Si, AlMg1SiCu) and cast iron castings (JIS G5501)

Shaft - Stainless and carbon steels (SUS303, S45C)

**Associated Products**

Motors: page 2-1

Couplings: page 8-1

Hardware: page 13-1

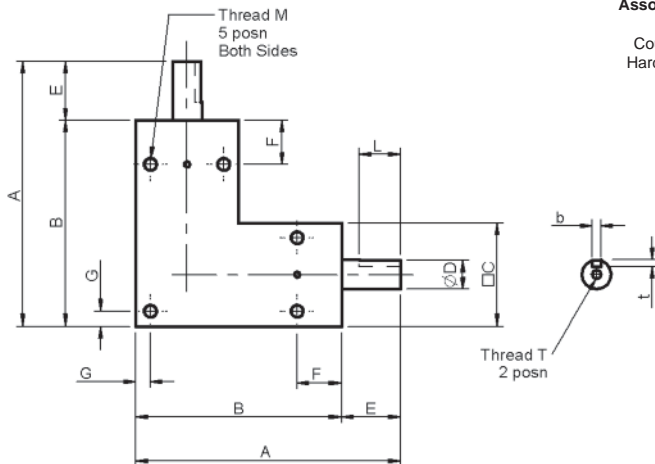

## Part number selection table

| Part Number | Gear Ratio | Body Matl* | C  | A   | B  | ØD h7 | E  | F  | G | Keyway |     |    | Set Screw |       | Shaft End |       |
|-------------|------------|------------|----|-----|----|-------|----|----|---|--------|-----|----|-----------|-------|-----------|-------|
|             |            |            |    |     |    |       |    |    |   | b      | t   | L  | M         | Depth | T         | Depth |
| BSH70L-001  | 1          | AL         | 27 | 70  | 54 | 6     | 16 | 9  | 4 | -      | -   | -  | M4        | 6     | -         | -     |
| BSH85L-001  |            | AL         | 32 | 85  | 64 | 8     | 21 | 10 | 5 | 3      | 1.8 | 14 | M5        | 7     | -         | -     |
| BSH95L-001  |            | AL         | 36 | 95  | 72 | 10    | 23 | 13 | 5 | 3      | 1.8 | 15 | M5        | 8     | -         | -     |
| BSH115L-001 |            | FC         | 45 | 115 | 90 | 12    | 25 | 20 | 5 | 4      | 2.5 | 20 | M5        | 12    | M4        | 8     |

| Part Number | Backlash (arcmin) | Maximum Overhang Load (N) | Weight (kg) |
|-------------|-------------------|---------------------------|-------------|
| BSH70L-001  | 15                | 25                        | 0.2         |
| BSH85L-001  | 15                | 36                        | 0.4         |
| BSH95L-001  | 15                | 58                        | 0.5         |
| BSH115L-001 | 10                | 83                        | 1.8         |

\*Body material and surface treatments

(AL) Al Alloy: A6063, A6061, black anodised with stainless steel shaft

(FC) Cast iron: FC200, FC250, black oxide with carbon steel shaft

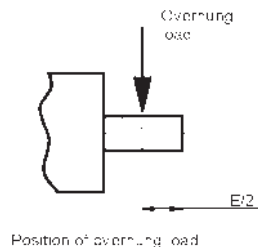

## Allowable rated torque table

| Part Number | Module | Teeth | Input Torque Nm at: |        |        |         |         |         |         |         |
|-------------|--------|-------|---------------------|--------|--------|---------|---------|---------|---------|---------|
|             |        |       | 250rpm              | 500rpm | 800rpm | 1000rpm | 1500rpm | 2000rpm | 2500rpm | 3000rpm |
| BSH70L-001  | 0.8    | 19    | 0.89                | 0.89   | 0.89   | 0.89    | 0.86    | 0.81    | 0.77    | 0.73    |
| BSH85L-001  | 1.0    | 19    | 1.95                | 1.95   | 1.95   | 1.95    | 1.81    | 1.69    | 1.59    | 1.50    |
| BSH95L-001  | 1.25   | 18    | 3.68                | 3.68   | 3.68   | 3.58    | 3.30    | 3.04    | 2.85    | 2.77    |
| BSH115L-001 | 1.5    | 19    | 5.23                | 5.23   | 5.15   | 5.01    | 4.69    | 4.40    | 4.25    | 4.13    |

## Features and options

- Product overview - see page 3-14



**Associated Products**  
Motors: page 2-1  
Couplings: page 8-1  
Hardware: page 13-1

All dimensions in mm  
Material:  
Body - Aluminium (ISO AlMg0.7Si,  
AlMg1SiCu)  
Shaft - Stainless steel  
(SUS303, S45C)

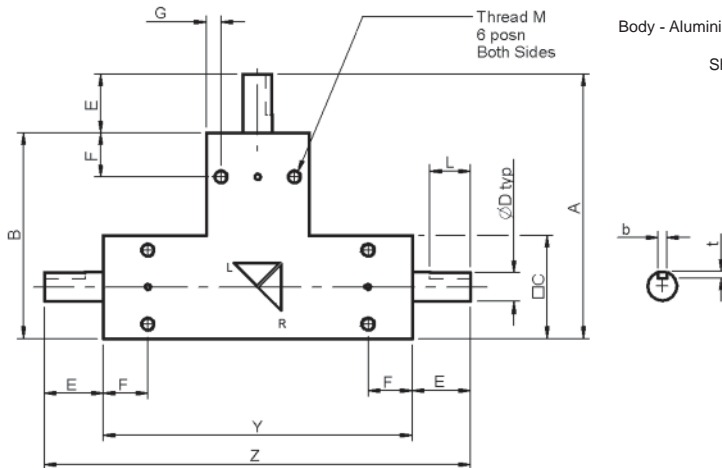

### Part number selection table

| Part Number | Gear Ratio | Body Matl* | Z   | Y   | C  | A  | B  | ØD h7 | E  | F  | G | Keyway |     |    | Set Screw |       |
|-------------|------------|------------|-----|-----|----|----|----|-------|----|----|---|--------|-----|----|-----------|-------|
|             |            |            |     |     |    |    |    |       |    |    |   | b      | t   | L  | M         | Depth |
| BSH70T-001  | 1          | AL         | 113 | 81  | 27 | 70 | 54 | 6     | 16 | 9  | 4 | -      | -   | -  | M4        | 6     |
| BSH85T-001  |            |            | 138 | 96  | 32 | 85 | 64 | 8     | 21 | 10 | 5 | 3      | 1.8 | 14 | M5        | 7     |
| BSH95T-001  |            |            | 154 | 108 | 36 | 95 | 72 | 10    | 23 | 13 | 5 | 3      | 1.8 | 15 | M5        | 8     |

| Part Number | Backlash (arcmin) | Maximum Overhang Load (N) | Weight (kg) |
|-------------|-------------------|---------------------------|-------------|
| BSH70T-001  | 15                | 25                        | 0.3         |
| BSH85T-001  |                   | 36                        | 0.5         |
| BSH95T-001  |                   | 58                        | 0.7         |

\*Body material and surface treatments  
(AL) Al Alloy: A6063, A6061, black anodised

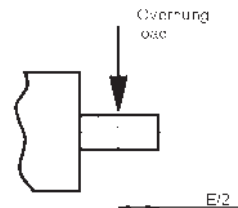

Position of overhung load

### Allowable rated torque table

| Part Number | Module | Teeth | Input Torque Nm at: |        |        |         |         |         |         |         |
|-------------|--------|-------|---------------------|--------|--------|---------|---------|---------|---------|---------|
|             |        |       | 250rpm              | 500rpm | 800rpm | 1000rpm | 1500rpm | 2000rpm | 2500rpm | 3000rpm |
| BSH70T-001  | 0.8    | 19    | 0.89                | 0.89   | 0.89   | 0.89    | 0.86    | 0.81    | 0.77    | 0.73    |
| BSH85T-001  | 1.0    | 19    | 1.95                | 1.95   | 1.95   | 1.95    | 1.81    | 1.69    | 1.59    | 1.50    |
| BSH95T-001  | 1.25   | 18    | 3.68                | 3.68   | 3.68   | 3.58    | 3.30    | 3.04    | 2.85    | 2.77    |

### **i** Features and options

- Product overview - see page 3-14



# BE Series Ratio 1:1

# Bevel Gearboxes

All dimensions in mm

Material:

Body - Anodised aluminium  
(ISO AlMg0.7Si, AlMg1SiCu)  
Shaft - Stainless steel (SUS303)

### Associated Products

Motors: page 2-1

Couplings: page 8-1

Hardware: page 13-1

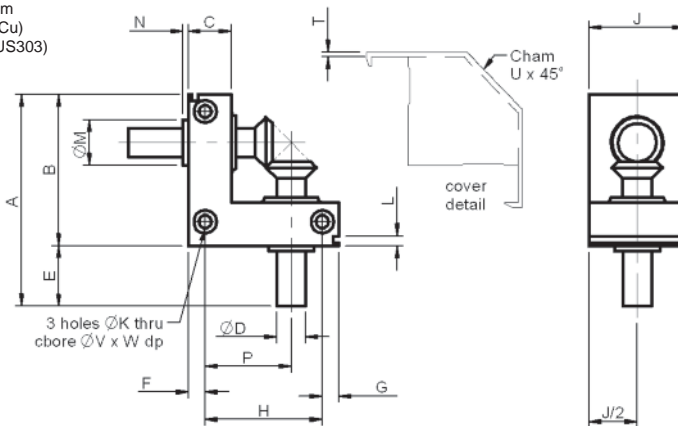

## Part number selection table

| Part Number | Gear Ratio | A  | B  | C  | ØD h8 | E  | F    | G   | H    | P    | J  | Drilled Holes & C/Bores |           |                |
|-------------|------------|----|----|----|-------|----|------|-----|------|------|----|-------------------------|-----------|----------------|
|             |            |    |    |    |       |    |      |     |      |      |    | Drill Hole ØK           | C/Bore ØV | C/Bore Depth W |
| BE40L-001   | 1          | 40 | 30 | 10 | 4     | 10 | 5.0  | 4.5 | 20.5 | 15.0 | 18 | 3.4                     | 6.5       | 3.5            |
| BE55L-001   |            | 55 | 40 | 13 | 5     | 15 | 6.5  | 5.0 | 28.5 | 21.5 | 25 | 3.4                     | 6.5       | 3.5            |
| BE70L-001A  |            | 70 | 50 | 16 | 6     | 20 | 8.0  | 6.0 | 36   | 27.0 | 30 | 4.3                     | 8.0       | 4.5            |
| BE70L-001B  |            | 70 | 50 | 16 | 8     | 20 | 8.0  | 6.0 | 36   | 27.0 | 30 | 4.3                     | 8.0       | 4.5            |
| BE88L-001A  |            | 88 | 63 | 20 | 10    | 25 | 10.0 | 7.0 | 46   | 33.0 | 40 | 5.2                     | 9.5       | 5.5            |
| BE88L-001B  |            | 88 | 63 | 20 | 12    | 25 | 10.0 | 7.0 | 46   | 33.0 | 40 | 5.2                     | 9.5       | 5.5            |

| Part Number | L   | ØM | N   | T   | U  | Weight (g) |
|-------------|-----|----|-----|-----|----|------------|
| BE40L-001   | 2.5 | 7  | 2.1 | 1.7 | 13 | 30         |
| BE55L-001   | 4.0 | 9  | 1.8 | 1.9 | 16 | 85         |
| BE70L-001A  | 4.5 | 11 | 1.8 | 2.1 | 20 | 155        |
| BE70L-001B  | 4.5 | 14 | 2.0 | 2.1 | 20 | 170        |
| BE88L-001A  | 5.0 | 18 | 2.0 | 2.1 | 27 | 375        |
| BE88L-001B  | 5.0 | 19 | 2.2 | 2.1 | 27 | 380        |



## Allowable rated torque table

| Part Number | Module | Teeth | Input Torque Ncm at: |        |        |        |
|-------------|--------|-------|----------------------|--------|--------|--------|
|             |        |       | 50rpm                | 100rpm | 250rpm | 500rpm |
| BE40L-001   | 0.5    | 20    | 9.8                  | 9.7    | 9.4    | 9.0    |
| BE55L-001   | 0.8    |       | 38.6                 | 38.0   | 36.5   | 34.3   |
| BE70L-001A  | 1.0    |       | 72.3                 | 71.0   | 67.6   | 62.6   |
| BE70L-001B  | 1.0    |       | 72.3                 | 71.0   | 67.6   | 62.6   |
| BE88L-001A  | 1.5    |       | 232.3                | 226.5  | 210.8  | 188.9  |
| BE88L-001B  | 1.5    |       | 232.3                | 226.5  | 210.8  | 188.9  |

## Features and options

- Product overview - see page 3-14
- BE series gearboxes are supplied with a clip-on plastic cover



**Associated Products**  
Motors: page 2-1  
Couplings: page 8-1  
Hardware: page 13-1

All dimensions in mm  
Material:  
Body - Anodised aluminium  
(ISO AlMg0.7Si, AlMg1SiCu)  
Shaft - Stainless steel (SUS303)

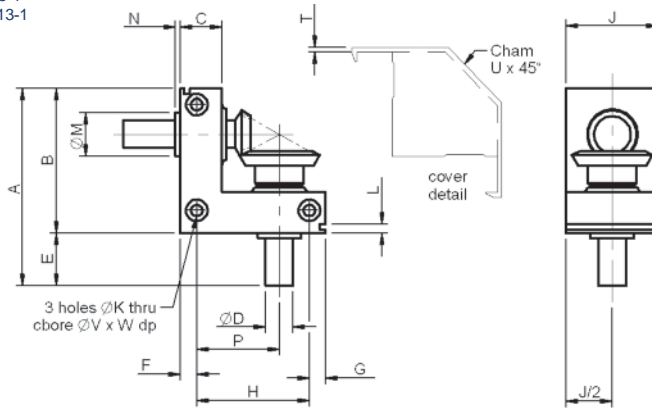

### Part number selection table

| Part Number | Gear Ratio | A  | B  | C  | ØD h8 | E  | F    | G | H    | P    | J  | Drilled Holes & C/Bores |           |                |
|-------------|------------|----|----|----|-------|----|------|---|------|------|----|-------------------------|-----------|----------------|
|             |            |    |    |    |       |    |      |   |      |      |    | Drill Hole ØK           | C/Bore ØV | C/Bore Depth W |
| BE55L-002   | 2          | 55 | 40 | 13 | 5     | 15 | 6.5  | 5 | 28.5 | 21.5 | 25 | 3.4                     | 6.5       | 3.5            |
| BE70L-002A  |            | 70 | 50 | 16 | 6     | 20 | 8.0  | 6 | 36   | 27.0 | 30 | 4.3                     | 8.0       | 4.5            |
| BE70L-002B  |            | 70 | 50 | 16 | 8     | 20 | 8.0  | 6 | 36   | 27.0 | 30 | 4.3                     | 8.0       | 4.5            |
| BE88L-002A  |            | 88 | 63 | 20 | 10    | 25 | 10.0 | 7 | 46   | 33.0 | 40 | 5.2                     | 9.5       | 5.5            |
| BE88L-002B  |            | 88 | 63 | 20 | 12    | 25 | 10.0 | 7 | 46   | 33.0 | 40 | 5.2                     | 9.5       | 5.5            |

| Part Number | L   | ØM | N   | T   | U  | Weight (g) |
|-------------|-----|----|-----|-----|----|------------|
| BE55L-002   | 4.0 | 9  | 1.8 | 1.9 | 16 | 80         |
| BE70L-002A  | 4.5 | 11 | 1.8 | 2.1 | 20 | 140        |
| BE70L-002B  | 4.5 | 14 | 2.0 | 2.1 | 20 | 165        |
| BE88L-002A  | 5.0 | 18 | 2.0 | 2.1 | 27 | 345        |
| BE88L-002B  | 5.0 | 19 | 2.2 | 2.1 | 27 | 375        |



### Allowable rated torque table

| Part Number | Module | Teeth | Input Torque Ncm at: |        |        |        |
|-------------|--------|-------|----------------------|--------|--------|--------|
|             |        |       | 50rpm                | 100rpm | 250rpm | 500rpm |
| BE55L-002   | 0.6    | 14/28 | 10.5                 | 10.4   | 10.2   | 9.9    |
| BE70L-002A  | 0.8    | 13/26 | 20.7                 | 20.6   | 20.1   | 19.3   |
| BE70L-002B  | 0.8    | 13/26 | 20.7                 | 20.6   | 20.1   | 19.3   |
| BE88L-002A  | 1.25   | 13/26 | 74.2                 | 73.2   | 70.3   | 65.9   |
| BE88L-002B  | 1.25   | 13/26 | 74.2                 | 73.2   | 70.3   | 65.9   |

### Features and options

- Product overview - see page 3-14
- BE series gearboxes are supplied with a clip-on plastic cover

Gearboxes





## Epicyclic Modules

Reliance offers a component gear set with a modular design approach for building a custom gearbox based on standard modules. It can be used as an individual stage, providing ratios of up to 5:1, or the modules can be stacked to create a higher ratio gearbox. It is ideal for heavier duty, or long-life, torque amplification, and speed reduction applications; the units have been used successfully in sealed sub-sea applications and in motorsports mechanisms.

The gear modules can also be supplied mounted in an aluminium housing complete with output shaft and support bearings, or as a housed unit completed with input and output shaft.



### Transmission efficiency

98% per single unit, 95% in double units, the power source may be smaller than with many other reduction gears.

### Noise reduction

Gear noise is reduced by a special construction of disk-sided planetary gears.

### Load equalised structure

The inherent problem of loadsharing with planetary gear systems is solved by the load equalised construction.

### High torque transmission

The epicyclic module is a compact unit with high torque transmission because it is designed to equalise the loads of each planetary gear.

### Many reduction ratios

It is possible to obtain many reduction ratios by combining standard units (3:1, 4:1, 5:1).

Gearboxes

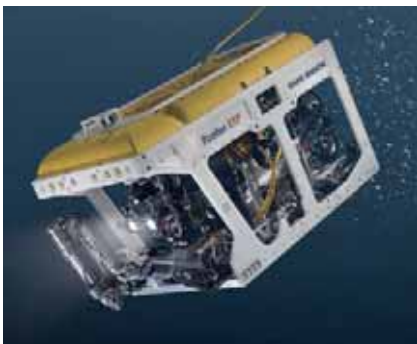

Sub-sea systems



Motorsports industry



## Part number structure

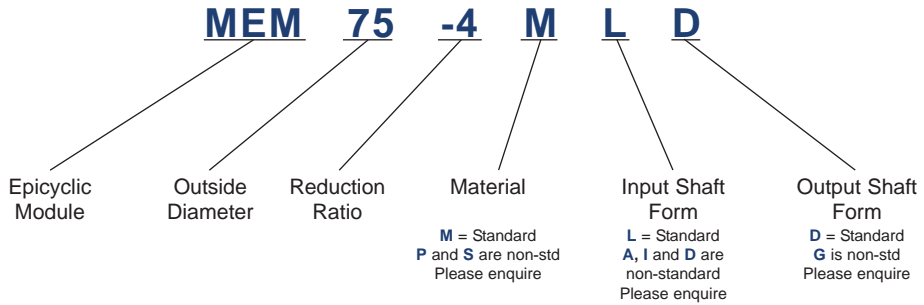

### Material

- M** = Metal carrier  
Metal housing  
Metal internal/planet gears  
Metal sun gear
- P** = Plastic carrier  
Plastic housing  
Plastic internal/planet gears  
Metal sun gear
- S** = Metal carrier  
Plastic housing  
Plastic internal/planet gears  
Metal sun gear

### Input shaft form

- L** = splined shaft 11 teeth 1.0 module 45° P.A. (standard)
- A** = D shaped shaft 8 mm diameter x 7mm
- I** = splined hole 8 mm diameter with 9 splines 0.75 module 20° P.A.
- D** = splined hole 11 teeth 1.0 module 45° P.A. (standard)

### Output shaft form

- D** = splined hole 12 mm diameter 11 splines 1.0 module 45° P.A. (standard)
- G** = splined hole 19.5 mm diameter 25 splines 0.75 module 45° P.A.

### Reduction ratios

- Metal units (M) Hybrid units (S) 3:1, 4:1, 5:1
- Plastic units (P) 3.11:1, 3.71:1, 4.8:1
- Insert 3 for 3:1, 4 for 4:1, 5 for 5:1



All dimensions in mm

**Associated Products**

Motors: page 2-1

Couplings: page 8-1

Hardware: page 13-1

Initial Module - MAD



Input Shaft (D Cut Hole)  
Ø8 x 7

Subsequent Module - MLD

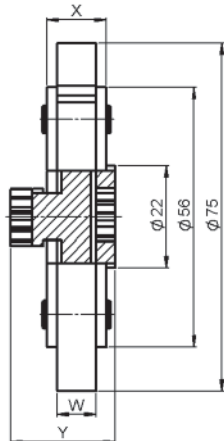

Input Shaft (External Spline)  
Splined hole Ø12  
11 Splines  
1 Module, 45° P.A.

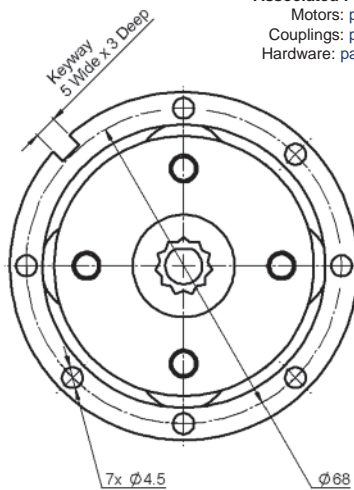

Output (Internal Spline)  
Splined hole Ø12  
11 Splines  
1 Module, 45° P.A.

## Part number selection table

| Unit Part Number | Ratio | Weight (g) | W    | X    | Y    | Inertia kg/cm <sup>2</sup> |
|------------------|-------|------------|------|------|------|----------------------------|
| MEM75-3MAD       | 3:1   | 231        | 8.4  | 12.6 | 14.8 | 4.22                       |
| MEM75-4MAD       | 4:1   | 228        |      |      |      | 4.25                       |
| MEM75-5MAD       | 5:1   | 248        |      |      |      | 4.38                       |
| MEM75-3MLD       | 3:1   | 240        |      |      | 22.6 | 4.24                       |
| MEM75-4MLD       | 4:1   | 248        |      |      |      | 4.27                       |
| MEM75-5MLD       | 5:1   | 257        |      |      |      | 4.39                       |
| MEM75-3MLD8      | 3:1   | 321        | 12.4 | 16.6 | 26.6 | 4.53                       |
| MEM75-4MLD8      | 4:1   | 315        |      |      |      | 4.44                       |
| MEM75-5MLD8      | 5:1   | 327        |      |      |      | 4.58                       |
| MEM75-4MDG12     | 4:1   | 500        | 16.4 | 20.8 | 25   | 4.96                       |
| MEM75-4MLG12     |       |            |      |      | 32.5 | 5.01                       |
| MEM75-5MLG12     |       |            |      |      |      | 5:1                        |

### Technical support

- Torque graphs - see page T3-4
- Complete gearhead information - see page T3-5
- Handling information - see page T3-6
- Mounting and assembly - see page T3-5
- Further technical information - see page T3-4
- Product overview - see page 3-24

### Product options

- Higher output variants available
- Housed units available (LGH and MEM26) - see page T3-6
- For range of accessories - see page 3-27



All dimensions in mm

### ACCESSORIES

The initial module accepts a D-shaped motor shaft. Subsequent modules use the input shaft (external spline) to plug into the output (internal spline). Finally, output internal spline adaptors are available, see below, and spacer rings should be inserted between each module as required.

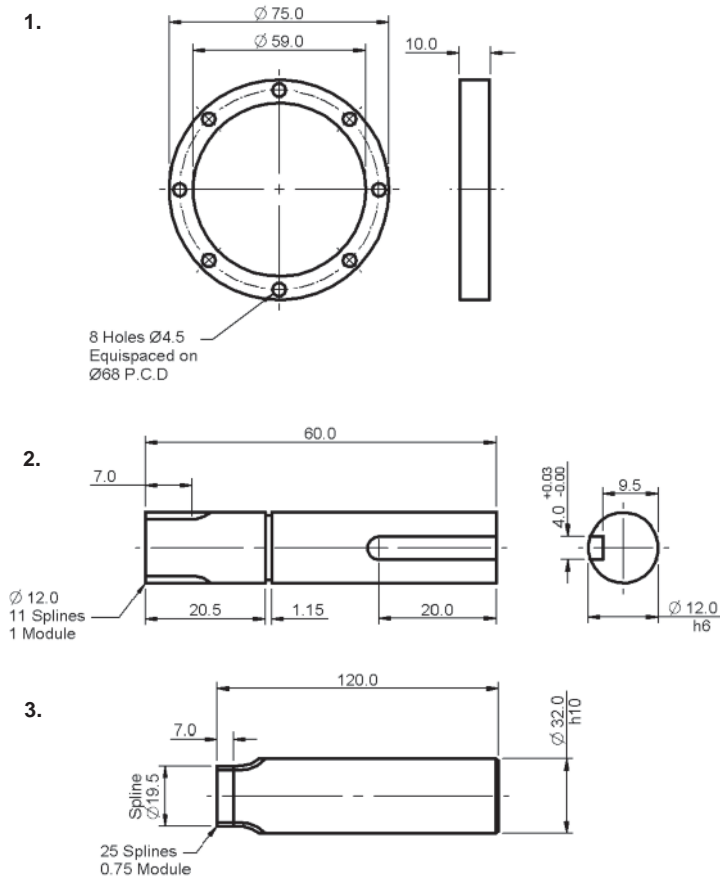

|    | Function                   | Part Number      | Material | Weight g | Description                                 |
|----|----------------------------|------------------|----------|----------|---|
| 1. | Spacer ring                | <b>MEM75-903</b> | POM      | 12       | For spacing modules at the correct distance |
| 2. | $\varnothing 12$ O/P shaft | <b>MEM75-907</b> | SCM435   | 50       | 10 Nm torque rated                          |
| 3. | $\varnothing 32$ O/P shaft | <b>MEM75-906</b> | S45C     | 720      | For customer to machine to requirements     |



## Custom gearboxes

As well as offering a range of standard gearboxes we also design and manufacture bespoke gearboxes. As with our bespoke gears (see page 4-4) these are typically used in the aerospace and defence markets, and other industries with performance-critical requirements.



With over 50 years' experience in gearbox design, manufacture, assembly and test Reliance's engineers have a wealth of knowledge to draw upon when designing a solution to a customer's specification. We have designed and built gearboxes for prime contractors and leading OEMs in the aerospace industry which are used in flight critical applications on global programmes such as Eurofighter Typhoon, Sea Harrier and Tornado.

We specialise in fine pitch gearing for long-life applications, short-life, high power applications and rotary to linear actuation drive mechanisms.

Our manufacturing capability extends to component cleaning and clean assembly, allowing us to address requirements for geared solutions for vacuum applications.

An extensive suite of test equipment enables thorough validation of the gearbox design and construction. This includes a Transmission Error Measurement System (TEMS) which enables investigation of the accuracy and backlash of the full geared system, environmental test equipment and accelerated life testing, all of which help ensure that the gearbox will perform within specification for the entire life of the product.

Gearboxes



Land defence



Military aerospace

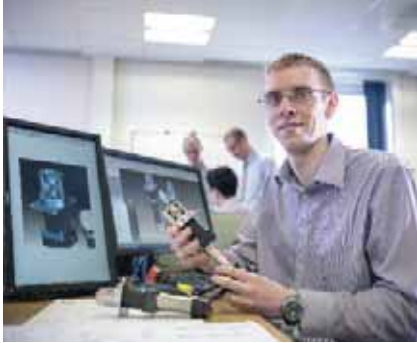

Design engineering



Environmental testing

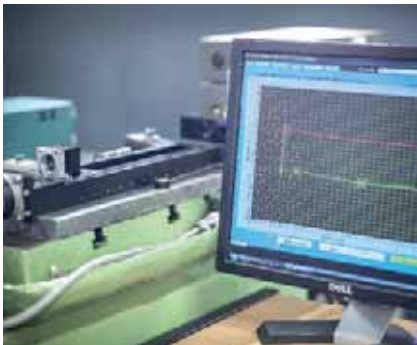

Gearbox Transmission Error Measurement (TEMS) trace



Gearbox characterisation



Production



Production testing



## Example modular gearbox

Modular gearbox designed and manufactured to custom specification for system test equipment.

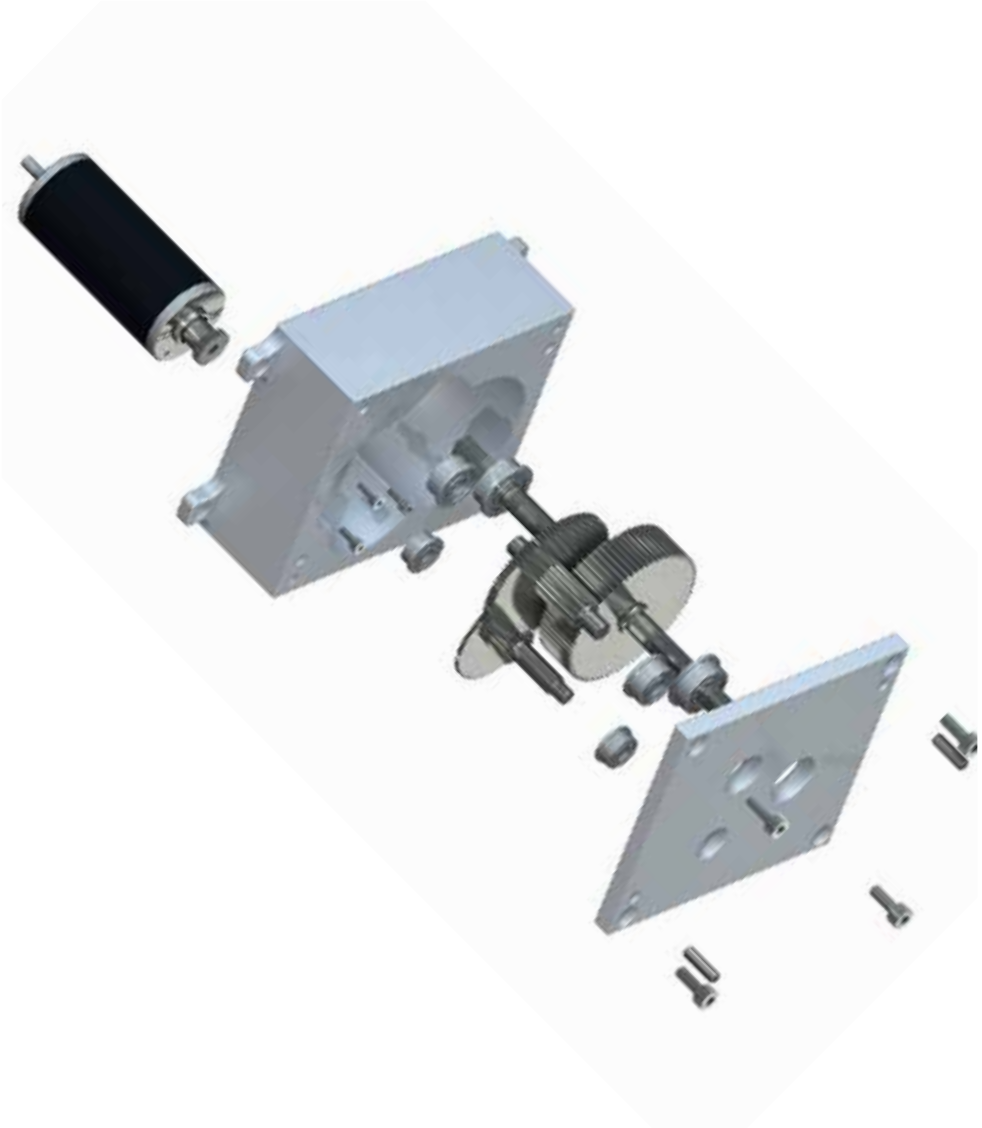





### Example planetary gearbox

High performance gearbox designed and manufactured to customer specification for airborne gimbal actuation.





# Section Contents

- Gear Range - Overview .....Page 4-2
- Precision Gears .....Page 4-6
  - Part Numbering .....Page 4-6
  - Anti-backlash Pinions, Miniature .....Page 4-7
  - Anti-backlash Pinions (pin and clamp hub) .....Page 4-12
  - Anti-backlash Gears (pin and clamp hub).....Page 4-22
  - Spur Gears (pin and clamp hub) .....Page 4-36
  - Hubless Spur Gears .....Page 4-52
  - Hardened Spur Gears .....Page 4-56
- Ground Gears - Overview .....Page 4-60
  - Ground Spur Pinion Gear Shafts .....Page 4-61
  - Ground Pin Hub Spur Gears.....Page 4-62
  - Keys and Keyways.....Page 4-69
- Brass Gears and Pinions- Overview.....Page 4-70
  - Brass Pinions .....Page 4-71
  - Brass Pin Hub Spur Gears .....Page 4-72
  - Brass Hubless Spur Gears .....Page 4-78
- Technical Information.....Page T4-1



## A complete precision gear range

With over 50 years of experience in the design and manufacture of precision spur gears, Reliance has developed an extensive range to suit a wide variety of customer applications. Alongside precision cut gears we offer hardened and precision ground gears for applications requiring higher load capacity and a very competitive range of brass gears for applications where there is a need to balance accuracy and load capacity against cost. Typical diameters range from 5 mm to 100 mm.

## Precision cut gears

Our precision cut spur gear range offers anti-backlash, spur, hubless and hardened gears with many hundreds of thousands of combinations of bore size, face width, material, module and number of teeth. In line with our commitment to meeting customer requirements, any tooth number that can be configured for any given gear diameter can be supplied. This allows our customers ultimate flexibility when selecting their gear ratio and the ability to use the smallest or most practical centre distance.

Gears are available in standard modules from 0.2–1.5, bore sizes from 2–25 mm and to a minimum quality class of AQ10 (for definition of AQ10 see [page T4-1](#)). Manufactured from aerospace standard stainless steel and aluminium alloy Reliance standard precision gears can be specified for the most demanding applications. For customers that require higher transmission accuracy, to measure position more accurately or extend life in high speed applications, all Reliance's precision gears are available up to quality AQ14.



For applications that require more torque transmission, a standard range of 17-4 PH, hardened to condition H1025, is available. Further material choices are offered, commonly PEEK or acetal can be specified where low noise and/or insulating properties are required. For other application-specific requirements our engineers can help in the selection of exotic materials or add some customisation features to the component.

Reliance anti-backlash gears have been developed over a number of years and are manufactured with a two-piece construction. The fixed plate and hub are manufactured in one piece, which provides maximum integrity when attaching the gear to a shaft. This manufacturing method is far superior when compared to alternative anti-backlash designs which use a three-piece construction, with the hub and fixed plate joined together by a metal deformation technique such as swaging or riveting.



Plain precision gears



Anti-backlash gears



Hubless gears



## Modification service

Reliance has a dedicated manufacturing cell where modifications can be carried out quickly and economically to customer specification. Typically weight reduction features or alternative fixing methods are requested – please contact us to discuss your requirement.



## On-line gear builder

For fast, efficient and accurate selection of our precision cut gears we provide a gear builder facility which is available to use on-line. The on-line selection process gives all the required technical and commercial information appropriate to the gear specification, including a 3D image, drawing, part description and item number, together with the price and delivery lead time.



Gear manufacture and test



On-line gear builder

## Precision ground gears

The precision ground spur gear range, manufactured from chromium molybdenum steel hardened to 49-55 HRC, and with tooth profiles manufactured to ISO grade 5, is ideal for higher loaded, mechatronic applications. Available from stock or on short delivery the bore and the faces of the gears are purposely left soft to enable quick modification to suit alternative fixing or shaft diameter requirements.

## Brass gears

The brass spur gear range is also available from stock or on a short delivery and provides customers with an economical alternative for less demanding applications. Manufactured from high grade brass, ISO CuZn39Pb3, the standard range of spur gears also includes pinion shafts with tooth numbers as low as 10 and a small range of internal gears (see [page 5-15](#)).



## Design and manufacture of custom gears

Alongside our extensive range of standard catalogue gears Reliance also designs and manufactures bespoke gears to customers' requirements. Reliance has over 50 years of experience in gearing, ranging from high accuracy, long life applications such as radar and optical payload applications, to very short life highly loaded aerospace applications.

Gear specialists at Reliance are very happy to offer advice on the design strategy for custom gears and can help with datum positioning and dimensioning to achieve the best possible accuracy at the most economical cost. For example, simply utilising the mounting feature of the gear as the datum for the gear cutting operation avoids unnecessary tolerance build ups and interim manufacturing operations.

Reliance's engineers have a detailed knowledge of the principles of gear tooth generation and the resulting contact conditions. This enables them to work with engineers in other industries to offer advice on the modification of gear teeth to provide bespoke contact conditions that enhance the performance of the gear pair, or to achieve an imposed centre distance within the constraints of the design environment.

Typical market areas are aerospace, space, defence and down-hole instrumentation where performance-critical applications demand a deep understanding of gear geometry. Both external, internal and combination gears can be manufactured using high accuracy hobbing and shaping machines with a module range of between 0.2 to 1.5 module and a diameter range from 2 to 330 mm.

Custom gears can be manufactured from a range of materials such as, but not limited to, stainless steel, aluminium alloy, precipitation hardening steel, phosphor bronze, titanium and other speciality metals, as well as high performance polymers such as PEEK. Reliance also works very closely with accredited and formally approved surface coating and heat treatment specialists to provide most industry standard processes.



During manufacturing all gears are individually inspected for gear quality and size using a dual flank inspection process with maximum accuracies of 3 microns tooth-to-tooth and 5 microns total composite error. For demanding applications gears are inspected for lead, pitch and profile on our Klingelnberg P40 gear measuring machine.

**Our expertise also extends to the associated structure in geared assemblies** where we can provide design for manufacture advice or a full design from specification service. Typical projects can involve concept design, development testing, prototype manufacture, performance validation testing and production manufacture with final acceptance testing, see [page 3-28](#).

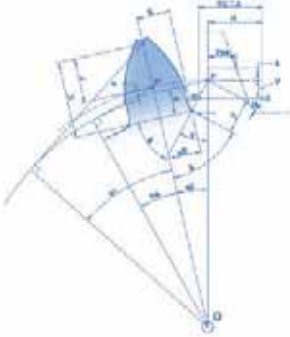

Custom gear design and development



Satellite gear, manufactured for SSTL, working in orbit

Custom gear manufacture

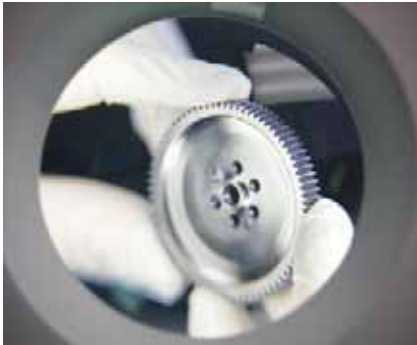

Gear deburring



Gear testing



Gear metrology



Wear and coating life test





**AP 05 S1 B4 F45 A - 55 B**

## Gear Type

|                                    |    |
|------------------------------------|----|
| Pin hub                            | P  |
| Clamp hub                          | C  |
| Hubless                            | F  |
| Anti-backlash pin hub              | AP |
| Anti-backlash clamp hub            | AC |
| Anti-backlash clamp hub, miniature | AR |

## Pitch

| Module   | DP  |          |                  |
|----------|-----|----------|------------------|
| 1.5      | 150 | 16       | 16 <sup>#</sup>  |
| 1.25     | 125 | 20       | 20 <sup>#</sup>  |
| 1.0      | 10  | 32       | 32 <sup>#</sup>  |
| 0.8      | 08  | 48       | 48 <sup>#</sup>  |
| 0.6      | 06  | 64       | 64 <sup>#</sup>  |
| 0.5      | 05  | 72       | 72 <sup>#</sup>  |
| 0.4      | 04  | 80       | 80 <sup>#</sup>  |
| 0.3      | 03  | 96       | 96 <sup>#</sup>  |
| 0.25     | 025 | 100      | 100 <sup>#</sup> |
| 0.2      | 02  | 120      | 120 <sup>#</sup> |
| 1 mmCP   | 1M  | 1/10 "CP | 31 <sup>#</sup>  |
| 2 mmCP   | 2M  | 1/20 "CP | 62 <sup>#</sup>  |
| 2.5 mmCP | 25M |          |                  |

## Material Code

|                                 |                 |
|---------------------------------|-----------------|
| Aluminium alloy                 | A1              |
| Stainless steel 303             | S1              |
| Stainless steel 316             | S2 <sup>#</sup> |
| Hardened stainless steel 17-4PH | S8              |
| Brass                           | B2 <sup>#</sup> |
| Acetal                          | D1 <sup>#</sup> |
| PEEK polymer                    | P1 <sup>#</sup> |

## Bore

| Metric | Imperial |                    |
|--------|----------|--------------------|
| 2 mm   | 5/64"    | B078 <sup>#</sup>  |
| 3 mm   | 1/8"     | B125 <sup>#</sup>  |
| 4 mm   | 0.12"    | B120 <sup>#</sup>  |
| 5 mm   | 3/16"    | B187 <sup>#</sup>  |
| 6 mm   | 1/4"     | B250 <sup>#</sup>  |
| 8 mm   | 5/16"    | B312 <sup>#</sup>  |
| 10 mm  | 3/8"     | B375 <sup>#</sup>  |
| 12 mm  | 11/16"   | B687 <sup>#</sup>  |
| 15 mm  | 1"       | B1000 <sup>#</sup> |

Drawing Issue  
Separator  
Number of Teeth

## Gear Quality

|                     |   |
|---------------------|---|
| AQ14                | A |
| AQ12                | B |
| AQ11                | C |
| AQ10 (leave blank)* |   |

\*Standard accuracy AQ10 (1.25 Mod, 20DP or finer), AQ9 (1.5 Mod, 16 DP or coarser).

## Face Width

|        |     |
|--------|-----|
| 2 mm   | F2  |
| 3 mm   | F3  |
| 3.3 mm | F33 |
| 3.5 mm | F35 |
| 4 mm   | F4  |
| 4.5 mm | F45 |
| 5 mm   | F5  |
| 6 mm   | F6  |
| 6.5 mm | F61 |
| 7 mm   | F7  |
| 8 mm   | F8  |
| 8.9 mm | F89 |
| 10 mm  | F10 |
| 12 mm  | F12 |

# indicates non-standard items. Please enquire for details regarding large modules, imperial pitches and bores, and alternative materials.

Part numbering information on this page refers to the precision gears from page 4-7 to 4-59.

# Anti-Backlash Pinions Miniature

2 mm Bore



## Associated Products

Clamp hub gears: page 4-36 to 4-50  
Shafts: page 11-2  
Bearings: page 12-1  
Gear clamps: page 11-4

All dimensions in mm  
General tolerances  $\pm 0.13$  mm  
Pressure angle 20°

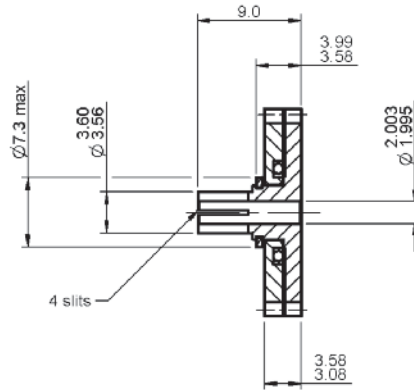

## Part number selection table

| Example Part No:- |   | AR06S1B2F33A- 25 |                 |     |
|-------------------|---|------------------|-----------------|-----|
| Standard Modules  | Basic Part Number<br>Standard Materials |                  | Number of Teeth |     |
|                   | Stainless Steel                         | Aluminium Alloy  | Min             | Max |
| 0.8               | AR08S1B2F33A-                           | AR08A1B2F33A-    | 16 †            | 21  |
| 0.6               | AR06S1B2F33A-                           | AR06A1B2F33A-    | 21              | 29  |
| 0.5               | AR05S1B2F33A-                           | AR05A1B2F33A-    | 24              | 36  |
| 0.4               | AR04S1B2F33A-                           | AR04A1B2F33A-    | 30              | 45  |
| 0.3               | AR03S1B2F33A-                           | AR03A1B2F33A-    | 38              | 61  |
| 0.25              | AR025S1B2F33A-                          | AR025A1B2F33A-   | 45              | 74  |
| 0.2               | AR02S1B2F33A-                           | AR02A1B2F33A-    | 56              | 93  |

† Gears of 16 teeth will be modified - see page T4-8

### **i** Features and options

- Gear quality AQ10 as standard - see page T4-1
- Higher gear qualities available - see page T4-1
- Imperial gears available
- For all gear types and options - see page 4-6
- Product overview - see pages 4-2 to 4-6

### **?** Technical support

- Material specifications - see page T4-4
- Lubrication - see page T4-10
- Installation information - see page T4-9
- Treatment specifications - see page T4-4
- Technical information - see pages T4-1 to T4-18
- For modified or fully bespoke gear solutions, please contact us

Precision  
Gears



All dimensions in mm  
 General tolerances  $\pm 0.13$  mm  
 Pressure angle  $20^\circ$

**Associated Products**  
 Clamp hub gears: page 4-36 to 4-50  
 Shafts: page 11-2  
 Bearings: page 12-1  
 Gear clamps: page 11-4

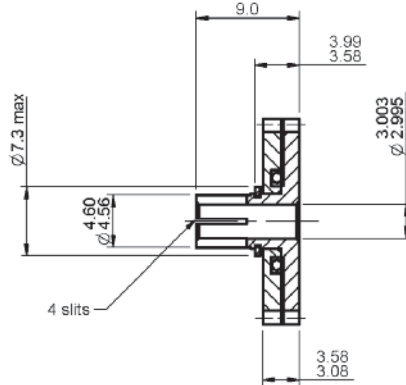

## Part number selection table

| Example Part No:- |   | AR06S1B3F33A- 25 |                 |     |
|-------------------|---|------------------|-----------------|-----|
| Standard Modules  | Basic Part Number<br>Standard Materials |                  | Number of Teeth |     |
|                   | Stainless Steel                         | Aluminium Alloy  | Min             | Max |
| 0.8               | AR08S1B3F33A-                           | AR08A1B3F33A-    | 16 †            | 21  |
| 0.6               | AR06S1B3F33A-                           | AR06A1B3F33A-    | 21              | 29  |
| 0.5               | AR05S1B3F33A-                           | AR05A1B3F33A-    | 24              | 36  |
| 0.4               | AR04S1B3F33A-                           | AR04A1B3F33A-    | 30              | 45  |
| 0.3               | AR03S1B3F33A-                           | AR03A1B3F33A-    | 38              | 61  |
| 0.25              | AR025S1B3F33A-                          | AR025A1B3F33A-   | 45              | 74  |
| 0.2               | AR02S1B3F33A-                           | AR02A1B3F33A-    | 56              | 93  |

† Gears of 16 teeth or fewer will be modified - see page T4-8

### **i** Features and options

- Gear quality AQ10 as standard - see page T4-1
- Higher gear qualities available - see page T4-1
- Imperial gears available
- For all gear types and options - see page 4-6
- Product overview - see pages 4-2 to 4-6

### **?** Technical support

- Material specifications - see page T4-4
- Lubrication - see page T4-10
- Installation information - see page T4-9
- Treatment specifications - see page T4-4
- Technical information - see pages T4-1 to T4-18
- For modified or fully bespoke gear solutions, please contact us

# Anti-Backlash Pinions Miniature

4 mm Bore



## Associated Products

Clamp hub gears: page 4-36 to 4-50

Shafts: page 11-2

Bearings: page 12-1

Gear clamps: page 11-4

All dimensions in mm

General tolerances  $\pm 0.13$  mm

Pressure angle 20°

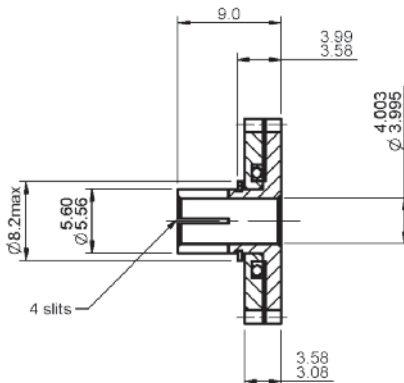

## Part number selection table

| Example Part No:- |   | AR06S1B4F33A- 25 |                 |     |
|-------------------|---|------------------|-----------------|-----|
| Standard Modules  | Basic Part Number<br>Standard Materials |                  | Number of Teeth |     |
|                   | Stainless Steel                         | Aluminium Alloy  | Min             | Max |
| 0.8               | AR08S1B4F33A-                           | AR08A1B4F33A-    | 18              | 21  |
| 0.6               | AR06S1B4F33A-                           | AR06A1B4F33A-    | 22              | 29  |
| 0.5               | AR05S1B4F33A-                           | AR05A1B4F33A-    | 26              | 36  |
| 0.4               | AR04S1B4F33A-                           | AR04A1B4F33A-    | 32              | 45  |
| 0.3               | AR03S1B4F33A-                           | AR03A1B4F33A-    | 41              | 61  |
| 0.25              | AR025S1B4F33A-                          | AR025A1B4F33A-   | 49              | 74  |
| 0.2               | AR02S1B4F33A-                           | AR02A1B4F33A-    | 60              | 93  |

## Features and options

- Gear quality AQ10 as standard - see page T4-1
- Higher gear qualities available - see page T4-1
- Imperial gears available
- For all gear types and options - see page 4-6
- Product overview - see pages 4-2 to 4-6

## Technical support

- Material specifications - see page T4-4
- Lubrication - see page T4-10
- Installation information - see page T4-9
- Treatment specifications - see page T4-4
- Technical information - see pages T4-1 to T4-18
- For modified or fully bespoke gear solutions, please contact us

Precision  
Gears

Contact us for product information, design support and custom solutions

sales@reliance.co.uk

+44 (0) 1484 601002

www.reliance.co.uk



All dimensions in mm  
General tolerances  $\pm 0.13$  mm  
Pressure angle  $20^\circ$

**Associated Products**  
Clamp hub gears: page 4-36 to 4-50  
Shafts: page 11-2  
Bearings: page 12-1  
Gear clamps: page 11-4

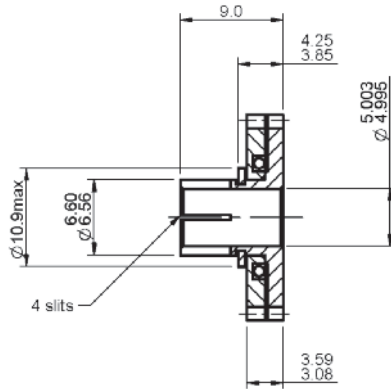

## Part number selection table

Example Part No:- AR06S1B5F33A- 25

| Standard Modules | Basic Part Number<br>Standard Materials |                 | Number of Teeth |               |
|------------------|---|-----------------|-----------------|---------------|
|                  | Stainless Steel                         | Aluminium Alloy | Min             | Max           |
|                  |   |                 | 0.8             | AR08S1B5F33A- |
| 0.6              | AR06S1B5F33A-                           | AR06A1B5F33A-   | 24              | 29            |
| 0.5              | AR05S1B5F33A-                           | AR05A1B5F33A-   | 28              | 36            |
| 0.4              | AR04S1B5F33A-                           | AR04A1B5F33A-   | 34              | 45            |
| 0.3              | AR03S1B5F33A-                           | AR03A1B5F33A-   | 44              | 61            |
| 0.25             | AR025S1B5F33A-                          | AR025A1B5F33A-  | 52              | 74            |
| 0.2              | AR02S1B5F33A-                           | AR02A1B5F33A-   | 65              | 93            |

Precision  
Gears

### **i** Features and options

- Gear quality AQ10 as standard - see page T4-1
- Higher gear qualities available - see page T4-1
- Imperial gears available
- For all gear types and options - see page 4-6
- Product overview - see pages 4-2 to 4-6

### **?** Technical support

- Material specifications - see page T4-4
- Lubrication - see page T4-10
- Installation information - see page T4-9
- Treatment specifications - see page T4-4
- Technical information - see pages T4-1 to T4-18
- For modified or fully bespoke gear solutions, please contact us

# Anti-Backlash Pinions Miniature

6 mm Bore



## Associated Products

Clamp hub gears: page 4-36 to 4-50  
Shafts: page 11-2  
Bearings: page 12-1  
Gear clamps: page 11-4

All dimensions in mm  
General tolerances  $\pm 0.13$  mm  
Pressure angle  $20^\circ$

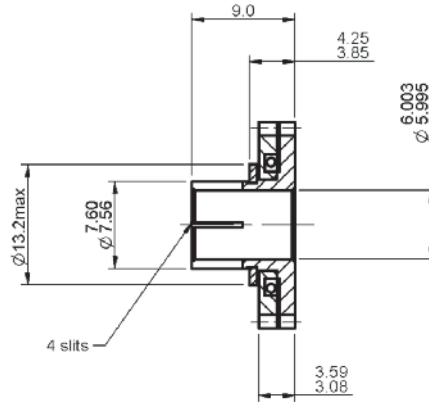

## Part number selection table

| Example Part No:- |   | AR06S1B6F33A- 26 |                 |     |
|-------------------|---|------------------|-----------------|-----|
| Standard Modules  | Basic Part Number<br>Standard Materials |                  | Number of Teeth |     |
|                   | Stainless Steel                         | Aluminium Alloy  | Min             | Max |
| 0.8               | AR08S1B6F33A-                           | AR08A1B6F33A-    | 21              | 21  |
| 0.6               | AR06S1B6F33A-                           | AR06A1B6F33A-    | 26              | 29  |
| 0.5               | AR05S1B6F33A-                           | AR05A1B6F33A-    | 31              | 36  |
| 0.4               | AR04S1B6F33A-                           | AR04A1B6F33A-    | 38              | 45  |
| 0.3               | AR03S1B6F33A-                           | AR03A1B6F33A-    | 49              | 61  |
| 0.25              | AR025S1B6F33A-                          | AR025A1B6F33A-   | 58              | 74  |
| 0.2               | AR02S1B6F33A-                           | AR02A1B6F33A-    | 72              | 93  |

## Features and options

- Gear quality AQ10 as standard - see page T4-1
- Higher gear qualities available - see page T4-1
- Imperial gears available
- For all gear types and options - see page 4-6
- Product overview - see pages 4-2 to 4-6

## Technical support

- Material specifications - see page T4-4
- Lubrication - see page T4-10
- Installation information - see page T4-9
- Treatment specifications - see page T4-4
- Technical information - see pages T4-1 to T4-18
- For modified or fully bespoke gear solutions, please contact us

Precision  
Gears



All dimensions in mm  
 General tolerances  $\pm 0.13$  mm  
 Pressure angle 20°

**Associated Products**  
 Clamp hub gears: page 4-36 to 4-50  
 Shafts: page 11-2  
 Bearings: page 12-1  
 Gear clamps: page 11-4

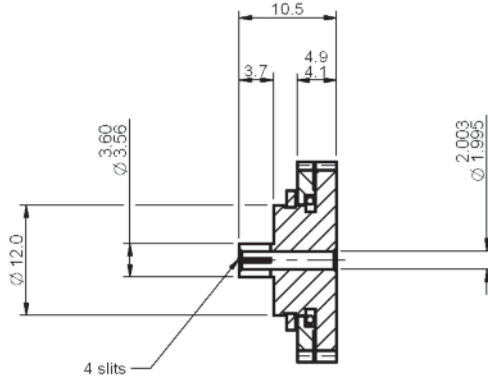

## Part number selection table

| Example Part No:- |                                      | <u>AC06S1B2F45A-</u> 35 |                 |     |
|-------------------|--------------------------------------|-------------------------|-----------------|-----|
| Standard Modules  | Basic Part Number Standard Materials |                         | Number of Teeth |     |
|                   | Stainless Steel                      | Aluminium Alloy         | Min             | Max |
| 1.5               | AC150S1B2F45A-                       | AC150A1B2F45A-          | 14 †            | 22  |
| 1.25              | AC125S1B2F45A-                       | AC125A1B2F45A-          | 16 †            | 27  |
| 1.0               | AC10S1B2F45A-                        | AC10A1B2F45A-           | 19              | 35  |
| 0.8               | AC08S1B2F45A-                        | AC08A1B2F45A-           | 23              | 44  |
| 0.6               | AC06S1B2F45A-                        | AC06A1B2F45A-           | 29              | 59  |
| 0.5               | AC05S1B2F45A-                        | AC05A1B2F45A-           | 34              | 72  |
| 0.4               | AC04S1B2F45A-                        | AC04A1B2F45A-           | 42              | 90  |
| 0.3               | AC03S1B2F45A-                        | AC03A1B2F45A-           | 55              | 121 |
| 0.25              | AC025S1B2F45A-                       | AC025A1B2F45A-          | 65              | 146 |
| 0.2               | AC02S1B2F45A-                        | AC02A1B2F45A-           | 80              | 183 |

† Gears of 16 teeth or fewer will be modified - see page T4-8

### **i** Features and options

- Gear quality AQ10 as standard - see page T4-1
- Gear quality AQ9 for 1.5 mod
- Higher gear qualities available - see page T4-1
- Imperial gears available
- For all gear types and options - see page 4-6
- Product overview - see pages 4-2 to 4-6

### **?** Technical support

- Material specifications - see page T4-4
- Lubrication - see page T4-10
- Installation information - see page T4-9
- Treatment specifications - see page T4-4
- Technical information - see pages T4-1 to T4-18
- For modified or fully bespoke gear solutions, please contact us





### Associated Products

Pin hub gears: page 4-37 to 4-51  
 Shafts: page 11-2  
 Bearings: page 12-1  
 Pins: page 13-18

All dimensions in mm  
 General tolerances  $\pm 0.13$  mm  
 Pressure angle 20°

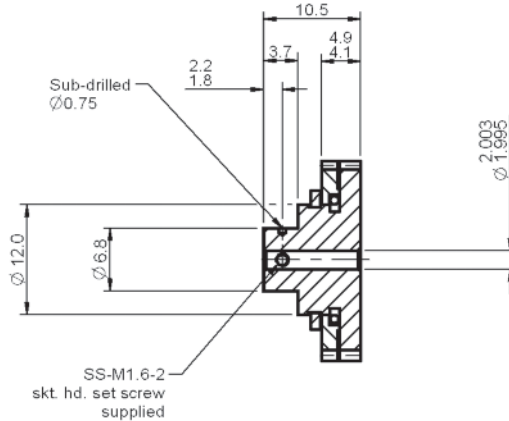

### Part number selection table

| Example Part No:- |                                      | AP06S1B2F45A- 35 |                 |     |
|-------------------|--------------------------------------|------------------|-----------------|-----|
| Standard Modules  | Basic Part Number Standard Materials |                  | Number of Teeth |     |
|                   | Stainless Steel                      | Aluminium Alloy  | Min             | Max |
| 1.5               | AP150S1B2F45A-                       | AP150A1B2F45A-   | 14 †            | 22  |
| 1.25              | AP125S1B2F45A-                       | AP125A1B2F45A-   | 16 †            | 27  |
| 1.0               | AP10S1B2F45A-                        | AP10A1B2F45A-    | 19              | 35  |
| 0.8               | AP08S1B2F45A-                        | AP08A1B2F45A-    | 23              | 44  |
| 0.6               | AP06S1B2F45A-                        | AP06A1B2F45A-    | 29              | 59  |
| 0.5               | AP05S1B2F45A-                        | AP05A1B2F45A-    | 34              | 72  |
| 0.4               | AP04S1B2F45A-                        | AP04A1B2F45A-    | 42              | 90  |
| 0.3               | AP03S1B2F45A-                        | AP03A1B2F45A-    | 55              | 121 |
| 0.25              | AP025S1B2F45A-                       | AP025A1B2F45A-   | 65              | 146 |
| 0.2               | AP02S1B2F45A-                        | AP02A1B2F45A-    | 80              | 183 |

† Gears of 16 teeth or fewer will be modified - see page T4-8

### Features and options

- Gear quality AQ10 as standard - see page T4-1
- Gear quality AQ9 for 1.5 mod
- Higher gear qualities available - see page T4-1
- Imperial gears available
- For all gear types and options - see page 4-6
- Product overview - see pages 4-2 to 4-6

### Technical support

- Material specifications - see page T4-4
- Lubrication - see page T4-10
- Installation information - see page T4-9
- Treatment specifications - see page T4-4
- Technical information - see pages T4-1 to T4-18
- For modified or fully bespoke gear solutions, please contact us

Precision Gears



All dimensions in mm  
 General tolerances  $\pm 0.13$  mm  
 Pressure angle  $20^\circ$

**Associated Products**  
 Clamp hub gears: page 4-36 to 4-50  
 Shafts: page 11-2  
 Bearings: page 12-1  
 Gear clamps: page 11-4

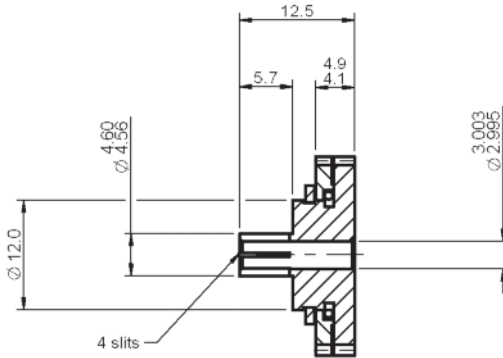

## Part number selection table

| Example Part No:- |   | <u>AC06S1B3F45A-</u> 35 |                 |     |
|-------------------|---|-------------------------|-----------------|-----|
| Standard Modules  | Basic Part Number<br>Standard Materials |                         | Number of Teeth |     |
|                   | Stainless Steel                         | Aluminium Alloy         | Min             | Max |
| 1.5               | AC150S1B3F45A-                          | AC150A1B3F45A-          | 14 †            | 22  |
| 1.25              | AC125S1B3F45A-                          | AC125A1B3F45A-          | 16 †            | 27  |
| 1.0               | AC10S1B3F45A-                           | AC10A1B3F45A-           | 19              | 35  |
| 0.8               | AC08S1B3F45A-                           | AC08A1B3F45A-           | 23              | 44  |
| 0.6               | AC06S1B3F45A-                           | AC06A1B3F45A-           | 29              | 59  |
| 0.5               | AC05S1B3F45A-                           | AC05A1B3F45A-           | 34              | 72  |
| 0.4               | AC04S1B3F45A-                           | AC04A1B3F45A-           | 42              | 90  |
| 0.3               | AC03S1B3F45A-                           | AC03A1B3F45A-           | 55              | 121 |
| 0.25              | AC025S1B3F45A-                          | AC025A1B3F45A-          | 65              | 146 |
| 0.2               | AC02S1B3F45A-                           | AC02A1B3F45A-           | 80              | 183 |

† Gears of 16 teeth or fewer will be modified - see page T4-8

### **i** Features and options

- Gear quality AQ10 as standard - see page T4-1
- Gear quality AQ9 for 1.5 mod
- Higher gear qualities available - see page T4-1
- Imperial gears available
- For all gear types and options - see page 4-6
- Product overview - see pages 4-2 to 4-6

### **?** Technical support

- Material specifications - see page T4-4
- Lubrication - see page T4-10
- Installation information - see page T4-9
- Treatment specifications - see page T4-4
- Technical information - see pages T4-1 to T4-18
- For modified or fully bespoke gear solutions, please contact us



### Associated Products

Pin hub gears: page 4-37 to 4-51  
 Shafts: page 11-2  
 Bearings: page 12-1  
 Pins: page 13-18

All dimensions in mm  
 General tolerances  $\pm 0.13$  mm  
 Pressure angle 20°

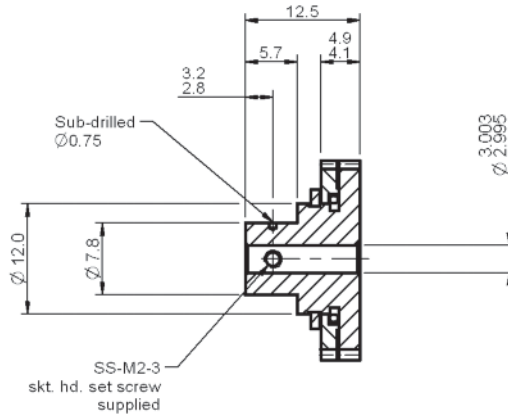

### Part number selection table

| Example Part No:- |   | AP06S1B3F45A- 35 |                 |     |
|-------------------|---|------------------|-----------------|-----|
| Standard Modules  | Basic Part Number<br>Standard Materials |                  | Number of Teeth |     |
|                   | Stainless Steel                         | Aluminium Alloy  | Min             | Max |
| 1.5               | AP150S1B3F45A-                          | AP150A1B3F45A-   | 14 †            | 22  |
| 1.25              | AP125S1B3F45A-                          | AP125A1B3F45A-   | 16 †            | 27  |
| 1.0               | AP10S1B3F45A-                           | AP10A1B3F45A-    | 19              | 35  |
| 0.8               | AP08S1B3F45A-                           | AP08A1B3F45A-    | 23              | 44  |
| 0.6               | AP06S1B3F45A-                           | AP06A1B3F45A-    | 29              | 59  |
| 0.5               | AP05S1B3F45A-                           | AP05A1B3F45A-    | 34              | 72  |
| 0.4               | AP04S1B3F45A-                           | AP04A1B3F45A-    | 42              | 90  |
| 0.3               | AP03S1B3F45A-                           | AP03A1B3F45A-    | 55              | 121 |
| 0.25              | AP025S1B3F45A-                          | AP025A1B3F45A-   | 65              | 146 |
| 0.2               | AP02S1B3F45A-                           | AP02A1B3F45A-    | 80              | 183 |

† Gears of 16 teeth or fewer will be modified - see page T4-8

### Features and options

- Gear quality AQ10 as standard - see page T4-1
- Gear quality AQ9 for 1.5 mod
- Higher gear qualities available - see page T4-1
- Imperial gears available
- For all gear types and options - see page 4-6
- Product overview - see pages 4-2 to 4-6

### Technical support

- Material specifications - see page T4-4
- Lubrication - see page T4-10
- Installation information - see page T4-9
- Treatment specifications - see page T4-4
- Technical information - see pages T4-1 to T4-18
- For modified or fully bespoke gear solutions, please contact us

Precision Gears



All dimensions in mm  
 General tolerances  $\pm 0.13$  mm  
 Pressure angle  $20^\circ$

**Associated Products**  
 Clamp hub gears: page 4-36 to 4-50  
 Shafts: page 11-2  
 Bearings: page 12-1  
 Gear clamps: page 11-4

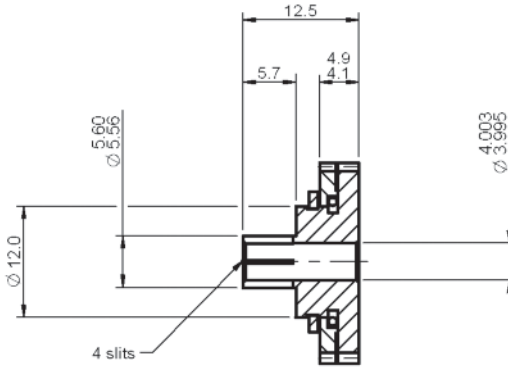

Part number selection table

| Example Part No:- |                                      | AC06S1B4F45A- 35 |                 |     |
|-------------------|--------------------------------------|------------------|-----------------|-----|
| Standard Modules  | Basic Part Number Standard Materials |                  | Number of Teeth |     |
|                   | Stainless Steel                      | Aluminium Alloy  | Min             | Max |
| 1.5               | AC150S1B4F45A-                       | AC150A1B4F45A-   | 14 †            | 22  |
| 1.25              | AC125S1B4F45A-                       | AC125A1B4F45A-   | 16 †            | 27  |
| 1.0               | AC10S1B4F45A-                        | AC10A1B4F45A-    | 19              | 35  |
| 0.8               | AC08S1B4F45A-                        | AC08A1B4F45A-    | 23              | 44  |
| 0.6               | AC06S1B4F45A-                        | AC06A1B4F45A-    | 29              | 59  |
| 0.5               | AC05S1B4F45A-                        | AC05A1B4F45A-    | 34              | 72  |
| 0.4               | AC04S1B4F45A-                        | AC04A1B4F45A-    | 42              | 90  |
| 0.3               | AC03S1B4F45A-                        | AC03A1B4F45A-    | 55              | 121 |
| 0.25              | AC025S1B4F45A-                       | AC025A1B4F45A-   | 65              | 146 |
| 0.2               | AC02S1B4F45A-                        | AC02A1B4F45A-    | 80              | 183 |

† Gears of 16 teeth or fewer will be modified - see page T4-8

Precision Gears

**i Features and options**

- Gear quality AQ10 as standard - see page T4-1
- Gear quality AQ9 for 1.5 mod
- Higher gear qualities available - see page T4-1
- Imperial gears available
- For all gear types and options - see page 4-6
- Product overview - see pages 4-2 to 4-6

**? Technical support**

- Material specifications - see page T4-4
- Lubrication - see page T4-10
- Installation information - see page T4-9
- Treatment specifications - see page T4-4
- Technical information - see pages T4-1 to T4-18
- For modified or fully bespoke gear solutions, please contact us



### Associated Products

Pin hub gears: page 4-37 to 4-51  
 Shafts: page 11-2  
 Bearings: page 12-1  
 Pins: page 13-18

All dimensions in mm  
 General tolerances  $\pm 0.13$  mm  
 Pressure angle 20°

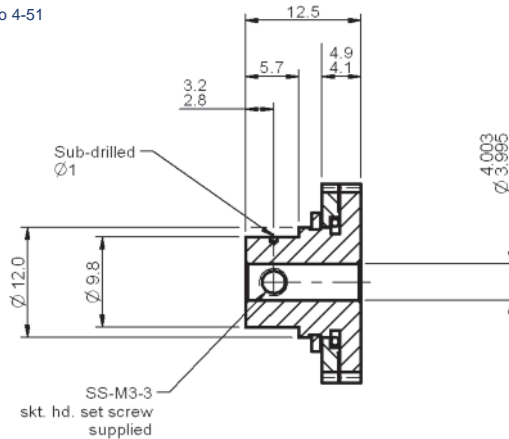

### Part number selection table

| Example Part No:- |   | AP06S1B4F45A- 35 |                 |     |
|-------------------|---|------------------|-----------------|-----|
| Standard Modules  | Basic Part Number<br>Standard Materials |                  | Number of Teeth |     |
|                   | Stainless Steel                         | Aluminium Alloy  | Min             | Max |
| 1.5               | AP150S1B4F45A-                          | AP150A1B4F45A-   | 14 †            | 22  |
| 1.25              | AP125S1B4F45A-                          | AP125A1B4F45A-   | 16 †            | 27  |
| 1.0               | AP10S1B4F45A-                           | AP10A1B4F45A-    | 19              | 35  |
| 0.8               | AP08S1B4F45A-                           | AP08A1B4F45A-    | 23              | 44  |
| 0.6               | AP06S1B4F45A-                           | AP06A1B4F45A-    | 29              | 59  |
| 0.5               | AP05S1B4F45A-                           | AP05A1B4F45A-    | 34              | 72  |
| 0.4               | AP04S1B4F45A-                           | AP04A1B4F45A-    | 42              | 90  |
| 0.3               | AP03S1B4F45A-                           | AP03A1B4F45A-    | 55              | 121 |
| 0.25              | AP025S1B4F45A-                          | AP025A1B4F45A-   | 65              | 146 |
| 0.2               | AP02S1B4F45A-                           | AP02A1B4F45A-    | 80              | 183 |

† Gears of 16 teeth or fewer will be modified - see page T4-8

### Features and options

- Gear quality AQ10 as standard - see page T4-1
- Gear quality AQ9 for 1.5 mod
- Higher gear qualities available - see page T4-1
- Imperial gears available
- For all gear types and options - see page 4-6
- Product overview - see pages 4-2 to 4-6

### Technical support

- Material specifications - see page T4-4
- Lubrication - see page T4-10
- Installation information - see page T4-9
- Treatment specifications - see page T4-4
- Technical information - see pages T4-1 to T4-18
- For modified or fully bespoke gear solutions, please contact us

Precision Gears



All dimensions in mm  
 General tolerances  $\pm 0.13$  mm  
 Pressure angle  $20^\circ$

**Associated Products**  
 Clamp hub gears: page 4-36 to 4-50  
 Shafts: page 11-2  
 Bearings: page 12-1  
 Gear clamps: page 11-4

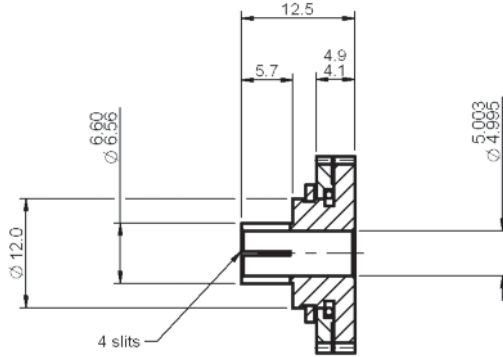

## Part number selection table

| Example Part No:- |   | <u>AC06S1B5F45A-</u> 35 |                 |     |
|-------------------|---|-------------------------|-----------------|-----|
| Standard Modules  | Basic Part Number<br>Standard Materials |                         | Number of Teeth |     |
|                   | Stainless Steel                         | Aluminium Alloy         | Min             | Max |
| 1.5               | AC150S1B5F45A-                          | AC150A1B5F45A-          | 14 †            | 22  |
| 1.25              | AC125S1B5F45A-                          | AC125A1B5F45A-          | 16 †            | 27  |
| 1.0               | AC10S1B5F45A-                           | AC10A1B5F45A-           | 19              | 35  |
| 0.8               | AC08S1B5F45A-                           | AC08A1B5F45A-           | 23              | 44  |
| 0.6               | AC06S1B5F45A-                           | AC06A1B5F45A-           | 29              | 59  |
| 0.5               | AC05S1B5F45A-                           | AC05A1B5F45A-           | 34              | 72  |
| 0.4               | AC04S1B5F45A-                           | AC04A1B5F45A-           | 42              | 90  |
| 0.3               | AC03S1B5F45A-                           | AC03A1B5F45A-           | 55              | 121 |
| 0.25              | AC025S1B5F45A-                          | AC025A1B5F45A-          | 65              | 146 |
| 0.2               | AC02S1B5F45A-                           | AC02A1B5F45A-           | 80              | 183 |

† Gears of 16 teeth or fewer will be modified - see page T4-8

### **i** Features and options

- Gear quality AQ10 as standard - see page T4-1
- Gear quality AQ9 for 1.5 mod
- Higher gear qualities available - see page T4-1
- Imperial gears available
- For all gear types and options - see page 4-6
- Product overview - see pages 4-2 to 4-6

### **?** Technical support

- Material specifications - see page T4-4
- Lubrication - see page T4-10
- Installation information - see page T4-9
- Treatment specifications - see page T4-4
- Technical information - see pages T4-1 to T4-18
- For modified or fully bespoke gear solutions, please contact us



### Associated Products

Pin hub gears: page 4-37 to 4-51  
 Shafts: page 11-2  
 Bearings: page 12-1  
 Pins: page 13-18

All dimensions in mm  
 General tolerances  $\pm 0.13$  mm  
 Pressure angle 20°

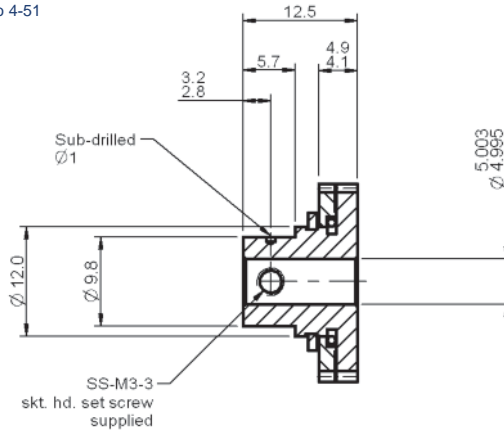

### Part number selection table

| Example Part No:- |   | AP06S1B5F45A- 35 |                 |     |
|-------------------|---|------------------|-----------------|-----|
| Standard Modules  | Basic Part Number<br>Standard Materials |                  | Number of Teeth |     |
|                   | Stainless Steel                         | Aluminium Alloy  | Min             | Max |
| 1.5               | AP150S1B5F45A-                          | AP150A1B5F45A-   | 14 †            | 22  |
| 1.25              | AP125S1B5F45A-                          | AP125A1B5F45A-   | 16 †            | 27  |
| 1.0               | AP10S1B5F45A-                           | AP10A1B5F45A-    | 19              | 35  |
| 0.8               | AP08S1B5F45A-                           | AP08A1B5F45A-    | 23              | 44  |
| 0.6               | AP06S1B5F45A-                           | AP06A1B5F45A-    | 29              | 59  |
| 0.5               | AP05S1B5F45A-                           | AP05A1B5F45A-    | 34              | 72  |
| 0.4               | AP04S1B5F45A-                           | AP04A1B5F45A-    | 42              | 90  |
| 0.3               | AP03S1B5F45A-                           | AP03A1B5F45A-    | 55              | 121 |
| 0.25              | AP025S1B5F45A-                          | AP025A1B5F45A-   | 65              | 146 |
| 0.2               | AP02S1B5F45A-                           | AP02A1B5F45A-    | 80              | 183 |

† Gears of 16 teeth or fewer will be modified - see page T4-8

### Features and options

- Gear quality AQ10 as standard - see page T4-1
- Gear quality AQ9 for 1.5 mod
- Higher gear qualities available - see page T4-1
- Imperial gears available
- For all gear types and options - see page 4-6
- Product overview - see pages 4-2 to 4-6

### Technical support

- Material specifications - see page T4-4
- Lubrication - see page T4-10
- Installation information - see page T4-9
- Treatment specifications - see page T4-4
- Technical information - see pages T4-1 to T4-18
- For modified or fully bespoke gear solutions, please contact us

Precision Gears



All dimensions in mm  
 General tolerances  $\pm 0.13$  mm  
 Pressure angle  $20^\circ$

**Associated Products**  
 Clamp hub gears: page 4-36 to 4-50  
 Shafts: page 11-2  
 Bearings: page 12-1  
 Gear clamps: page 11-4

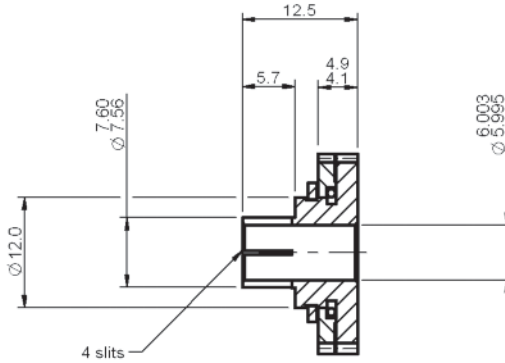

## Part number selection table

| Example Part No:- |                                      | <u>AC06S1B6F45A-</u> 35 |                 |     |
|-------------------|--------------------------------------|-------------------------|-----------------|-----|
| Standard Modules  | Basic Part Number Standard Materials |                         | Number of Teeth |     |
|                   | Stainless Steel                      | Aluminium Alloy         | Min             | Max |
| 1.5               | AC150S1B6F45A-                       | AC150A1B6F45A-          | 14 †            | 22  |
| 1.25              | AC125S1B6F45A-                       | AC125A1B6F45A-          | 16 †            | 27  |
| 1.0               | AC10S1B6F45A-                        | AC10A1B6F45A-           | 19              | 35  |
| 0.8               | AC08S1B6F45A-                        | AC08A1B6F45A-           | 23              | 44  |
| 0.6               | AC06S1B6F45A-                        | AC06A1B6F45A-           | 29              | 59  |
| 0.5               | AC05S1B6F45A-                        | AC05A1B6F45A-           | 34              | 72  |
| 0.4               | AC04S1B6F45A-                        | AC04A1B6F45A-           | 42              | 90  |
| 0.3               | AC03S1B6F45A-                        | AC03A1B6F45A-           | 55              | 121 |
| 0.25              | AC025S1B6F45A-                       | AC025A1B6F45A-          | 65              | 146 |
| 0.2               | AC02S1B6F45A-                        | AC02A1B6F45A-           | 80              | 183 |

† Gears of 16 teeth or fewer will be modified - see page T4-8

### **i** Features and options

- Gear quality AQ10 as standard - see page T4-1
- Gear quality AQ9 for 1.5 mod
- Higher gear qualities available - see page T4-1
- Imperial gears available
- For all gear types and options - see page 4-6
- Product overview - see pages 4-2 to 4-6

### **?** Technical support

- Material specifications - see page T4-4
- Lubrication - see page T4-10
- Installation information - see page T4-9
- Treatment specifications - see page T4-4
- Technical information - see pages T4-1 to T4-18
- For modified or fully bespoke gear solutions, please contact us





### Associated Products

Pin hub gears: page 4-37 to 4-51  
 Shafts: page 11-2  
 Bearings: page 12-1  
 Pins: page 13-18

All dimensions in mm  
 General tolerances  $\pm 0.13$  mm  
 Pressure angle 20°

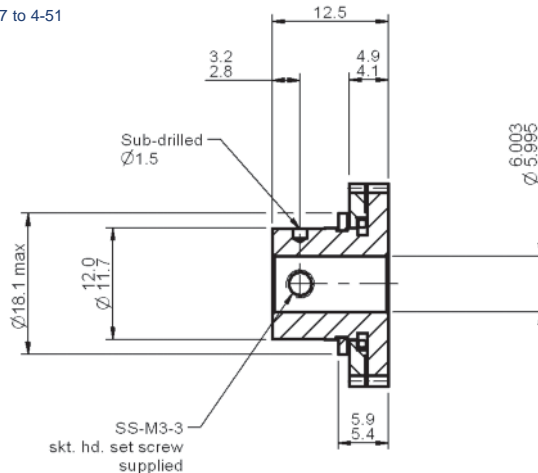

### Part number selection table

| Example Part No:- |                                      | <b>AP06S1B6F45A- 35</b> |                 |     |
|-------------------|--------------------------------------|-------------------------|-----------------|-----|
| Standard Modules  | Basic Part Number Standard Materials |                         | Number of Teeth |     |
|                   | Stainless Steel                      | Aluminium Alloy         | Min             | Max |
| 1.5               | AP150S1B6F45A-                       | AP150A1B6F45A-          | 14 †            | 22  |
| 1.25              | AP125S1B6F45A-                       | AP125A1B6F45A-          | 16 †            | 27  |
| 1.0               | AP10S1B6F45A-                        | AP10A1B6F45A-           | 19              | 35  |
| 0.8               | AP08S1B6F45A-                        | AP08A1B6F45A-           | 23              | 44  |
| 0.6               | AP06S1B6F45A-                        | AP06A1B6F45A-           | 29              | 59  |
| 0.5               | AP05S1B6F45A-                        | AP05A1B6F45A-           | 34              | 72  |
| 0.4               | AP04S1B6F45A-                        | AP04A1B6F45A-           | 42              | 90  |
| 0.3               | AP03S1B6F45A-                        | AP03A1B6F45A-           | 55              | 121 |
| 0.25              | AP025S1B6F45A-                       | AP025A1B6F45A-          | 65              | 146 |
| 0.2               | AP02S1B6F45A-                        | AP02A1B6F45A-           | 80              | 183 |

† Gears of 16 teeth or fewer will be modified - see page T4-8

### Features and options

- Gear quality AQ10 as standard - see page T4-1
- Gear quality AQ9 for 1.5 mod
- Higher gear qualities available - see page T4-1
- Imperial gears available
- For all gear types and options - see page 4-6
- Product overview - see pages 4-2 to 4-6

### Technical support

- Material specifications - see page T4-4
- Lubrication - see page T4-10
- Installation information - see page T4-9
- Treatment specifications - see page T4-4
- Technical information - see pages T4-1 to T4-18
- For modified or fully bespoke gear solutions, please contact us

Precision Gears



All dimensions in mm  
 General tolerances  $\pm 0.13$  mm  
 Pressure angle 20°

**Associated Products**  
 Clamp hub gears: page 4-36 to 4-50  
 Shafts: page 11-2  
 Bearings: page 12-1  
 Gear clamps: page 11-4

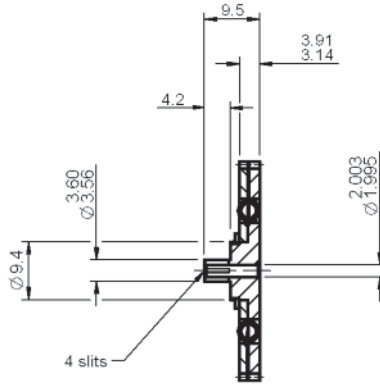

## Part number selection table

| Example Part No:- |   | AC06S1B2F35A- 65 |                 |     |
|-------------------|---|------------------|-----------------|-----|
| Standard Modules  | Basic Part Number<br>Standard Materials |                  | Number of Teeth |     |
|                   | Stainless Steel                         | Aluminium Alloy  | Min             | Max |
| 1.5               | AC150S1B2F35A-                          | AC150A1B2F35A-   | 24              | 46  |
| 1.25              | AC125S1B2F35A-                          | AC125A1B2F35A-   | 28              | 56  |
| 1.0               | AC10S1B2F35A-                           | AC10A1B2F35A-    | 34              | 70  |
| 0.8               | AC08S1B2F35A-                           | AC08A1B2F35A-    | 42              | 88  |
| 0.6               | AC06S1B2F35A-                           | AC06A1B2F35A-    | 55              | 119 |
| 0.5               | AC05S1B2F35A-                           | AC05A1B2F35A-    | 66              | 143 |
| 0.4               | AC04S1B2F35A-                           | AC04A1B2F35A-    | 81              | 179 |
| 0.3               | AC03S1B2F35A-                           | AC03A1B2F35A-    | 107             | 240 |
| 0.25              | AC025S1B2F35A-                          | AC025A1B2F35A-   | 128             | 289 |
| 0.2               | AC02S1B2F35A-                           | AC02A1B2F35A-    | 159             | 361 |

Precision Gears

### Features and options

- Gear quality AQ10 as standard - see page T4-1
- Gear quality AQ9 for 1.5 mod
- Higher gear qualities available - see page T4-1
- Imperial gears available
- For all gear types and options - see page 4-6
- Product overview - see pages 4-2 to 4-6

### Technical support

- Material specifications - see page T4-4
- Lubrication - see page T4-10
- Installation information - see page T4-9
- Treatment specifications - see page T4-4
- Technical information - see pages T4-1 to T4-18
- For modified or fully bespoke gear solutions, please contact us



### Associated Products

Pin hub gears: page 4-37 to 4-51  
 Shafts: page 11-2  
 Bearings: page 12-1  
 Pins: page 13-18

All dimensions in mm  
 General tolerances  $\pm 0.13$  mm  
 Pressure angle 20°

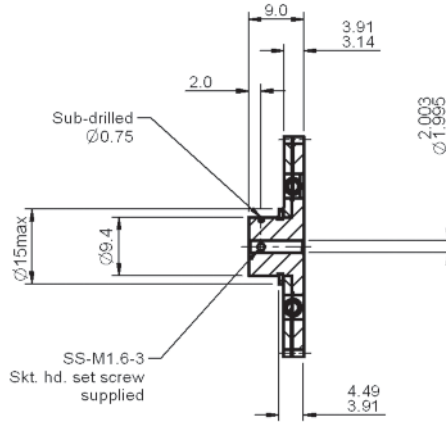

### Part number selection table

| Example Part No:- |   | <b>AP06S1B2F35A- 65</b> |                 |     |
|-------------------|---|-------------------------|-----------------|-----|
| Standard Modules  | Basic Part Number<br>Standard Materials |                         | Number of Teeth |     |
|                   | Stainless Steel                         | Aluminium Alloy         | Min             | Max |
| 1.5               | AP150S1B2F35A-                          | AP150A1B2F35A-          | 24              | 46  |
| 1.25              | AP125S1B2F35A-                          | AP125A1B2F35A-          | 28              | 56  |
| 1.0               | AP10S1B2F35A-                           | AP10A1B2F35A-           | 34              | 70  |
| 0.8               | AP08S1B2F35A-                           | AP08A1B2F35A-           | 42              | 88  |
| 0.6               | AP06S1B2F35A-                           | AP06A1B2F35A-           | 55              | 119 |
| 0.5               | AP05S1B2F35A-                           | AP05A1B2F35A-           | 66              | 143 |
| 0.4               | AP04S1B2F35A-                           | AP04A1B2F35A-           | 81              | 179 |
| 0.3               | AP03S1B2F35A-                           | AP03A1B2F35A-           | 107             | 240 |
| 0.25              | AP025S1B2F35A-                          | AP025A1B2F35A-          | 128             | 289 |
| 0.2               | AP02S1B2F35A-                           | AP02A1B2F35A-           | 159             | 361 |

### **i** Features and options

- Gear quality AQ10 as standard - see page T4-1
- Gear quality AQ9 for 1.5 mod
- Higher gear qualities available - see page T4-1
- Imperial gears available
- For all gear types and options - see page 4-6
- Product overview - see pages 4-2 to 4-6

### **?** Technical support

- Material specifications - see page T4-4
- Lubrication - see page T4-10
- Installation information - see page T4-9
- Treatment specifications - see page T4-4
- Technical information - see pages T4-1 to T4-18
- For modified or fully bespoke gear solutions, please contact us

Precision Gears



All dimensions in mm  
 General tolerances  $\pm 0.13$  mm  
 Pressure angle  $20^\circ$

**Associated Products**  
 Clamp hub gears: page 4-36 to 4-50  
 Shafts: page 11-2  
 Bearings: page 12-1  
 Gear clamps: page 11-4

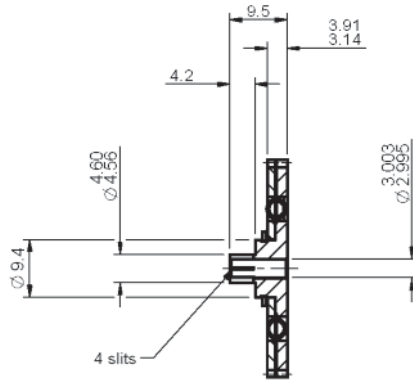

## Part number selection table

| Example Part No:- |   | <u>AC06S1B3F35A-</u> 65 |                 |     |
|-------------------|---|-------------------------|-----------------|-----|
| Standard Modules  | Basic Part Number<br>Standard Materials |                         | Number of Teeth |     |
|                   | Stainless Steel                         | Aluminium Alloy         | Min             | Max |
| 1.5               | AC150S1B3F35A-                          | AC150A1B3F35A-          | 24              | 46  |
| 1.25              | AC125S1B3F35A-                          | AC125A1B3F35A-          | 28              | 56  |
| 1.0               | AC10S1B3F35A-                           | AC10A1B3F35A-           | 34              | 70  |
| 0.8               | AC08S1B3F35A-                           | AC08A1B3F35A-           | 42              | 88  |
| 0.6               | AC06S1B3F35A-                           | AC06A1B3F35A-           | 55              | 119 |
| 0.5               | AC05S1B3F35A-                           | AC05A1B3F35A-           | 66              | 143 |
| 0.4               | AC04S1B3F35A-                           | AC04A1B3F35A-           | 81              | 179 |
| 0.3               | AC03S1B3F35A-                           | AC03A1B3F35A-           | 107             | 240 |
| 0.25              | AC025S1B3F35A-                          | AC025A1B3F35A-          | 128             | 289 |
| 0.2               | AC02S1B3F35A-                           | AC02A1B3F35A-           | 159             | 361 |

Precision Gears

### **i** Features and options

- Gear quality AQ10 as standard - see page T4-1
- Gear quality AQ9 for 1.5 mod
- Higher gear qualities available - see page T4-1
- Imperial gears available
- For all gear types and options - see page 4-6
- Product overview - see pages 4-2 to 4-6

### **?** Technical support

- Material specifications - see page T4-4
- Lubrication - see page T4-10
- Installation information - see page T4-9
- Treatment specifications - see page T4-4
- Technical information - see pages T4-1 to T4-18
- For modified or fully bespoke gear solutions, please contact us



### Associated Products

Pin hub gears: page 4-37 to 4-51  
 Shafts: page 11-2  
 Bearings: page 12-1  
 Pins: page 13-18

All dimensions in mm  
 General tolerances  $\pm 0.13$  mm  
 Pressure angle 20°

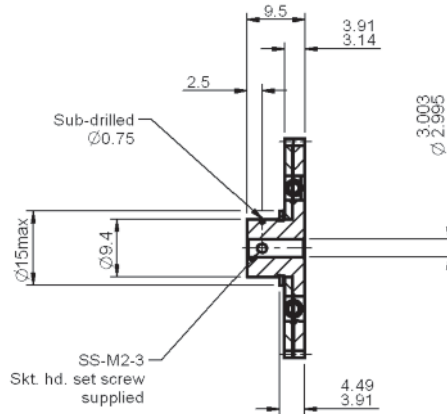

### Part number selection table

| Example Part No:- |   | <u>AP06S1B3F35A-</u> 65 |                 |     |
|-------------------|---|-------------------------|-----------------|-----|
| Standard Modules  | Basic Part Number<br>Standard Materials |                         | Number of Teeth |     |
|                   | Stainless Steel                         | Aluminium Alloy         | Min             | Max |
| 1.5               | AP150S1B3F35A-                          | AP150A1B3F35A-          | 24              | 46  |
| 1.25              | AP125S1B3F35A-                          | AP125A1B3F35A-          | 28              | 56  |
| 1.0               | AP10S1B3F35A-                           | AP10A1B3F35A-           | 34              | 70  |
| 0.8               | AP08S1B3F35A-                           | AP08A1B3F35A-           | 42              | 88  |
| 0.6               | AP06S1B3F35A-                           | AP06A1B3F35A-           | 55              | 119 |
| 0.5               | AP05S1B3F35A-                           | AP05A1B3F35A-           | 66              | 143 |
| 0.4               | AP04S1B3F35A-                           | AP04A1B3F35A-           | 81              | 179 |
| 0.3               | AP03S1B3F35A-                           | AP03A1B3F35A-           | 107             | 240 |
| 0.25              | AP025S1B3F35A-                          | AP025A1B3F35A-          | 128             | 289 |
| 0.2               | AP02S1B3F35A-                           | AP02A1B3F35A-           | 159             | 361 |

### **i** Features and options

- Gear quality AQ10 as standard - see page T4-1
- Gear quality AQ9 for 1.5 mod
- Higher gear qualities available - see page T4-1
- Imperial gears available
- For all gear types and options - see page 4-6
- Product overview - see pages 4-2 to 4-6

### **?** Technical support

- Material specifications - see page T4-4
- Lubrication - see page T4-10
- Installation information - see page T4-9
- Treatment specifications - see page T4-4
- Technical information - see pages T4-1 to T4-18
- For modified or fully bespoke gear solutions, please contact us

Precision Gears



All dimensions in mm  
 General tolerances  $\pm 0.13$  mm  
 Pressure angle  $20^\circ$

**Associated Products**  
 Clamp hub gears: page 4-36 to 4-50  
 Shafts: page 11-2  
 Bearings: page 12-1  
 Gear clamps: page 11-4

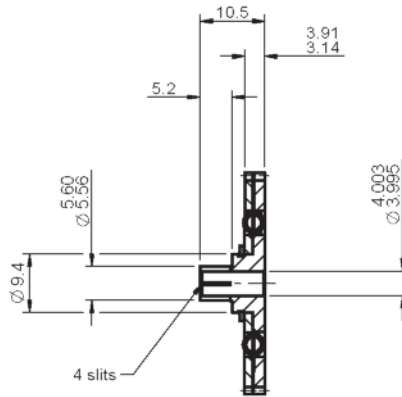

## Part number selection table

| Example Part No:- |   | <u>AC06S1B4F35A-</u> 65 |                 |     |
|-------------------|---|-------------------------|-----------------|-----|
| Standard Modules  | Basic Part Number<br>Standard Materials |                         | Number of Teeth |     |
|                   | Stainless Steel                         | Aluminium Alloy         | Min             | Max |
| 1.5               | AC150S1B4F35A-                          | AC150A1B4F35A-          | 24              | 46  |
| 1.25              | AC125S1B4F35A-                          | AC125A1B4F35A-          | 28              | 56  |
| 1.0               | AC10S1B4F35A-                           | AC10A1B4F35A-           | 34              | 70  |
| 0.8               | AC08S1B4F35A-                           | AC08A1B4F35A-           | 42              | 88  |
| 0.6               | AC06S1B4F35A-                           | AC06A1B4F35A-           | 55              | 119 |
| 0.5               | AC05S1B4F35A-                           | AC05A1B4F35A-           | 66              | 143 |
| 0.4               | AC04S1B4F35A-                           | AC04A1B4F35A-           | 81              | 179 |
| 0.3               | AC03S1B4F35A-                           | AC03A1B4F35A-           | 107             | 240 |
| 0.25              | AC025S1B4F35A-                          | AC025A1B4F35A-          | 128             | 289 |
| 0.2               | AC02S1B4F35A-                           | AC02A1B4F35A-           | 159             | 361 |

Precision Gears

### **i** Features and options

- Gear quality AQ10 as standard - see page T4-1
- Gear quality AQ9 for 1.5 mod
- Higher gear qualities available - see page T4-1
- Imperial gears available
- For all gear types and options - see page 4-6
- Product overview - see pages 4-2 to 4-6

### **?** Technical support

- Material specifications - see page T4-4
- Lubrication - see page T4-10
- Installation information - see page T4-9
- Treatment specifications - see page T4-4
- Technical information - see pages T4-1 to T4-18
- For modified or fully bespoke gear solutions, please contact us



### Associated Products

Pin hub gears: page 4-37 to 4-51  
 Shafts: page 11-2  
 Bearings: page 12-1  
 Pins: page 13-18

All dimensions in mm  
 General tolerances  $\pm 0.13$  mm  
 Pressure angle 20°

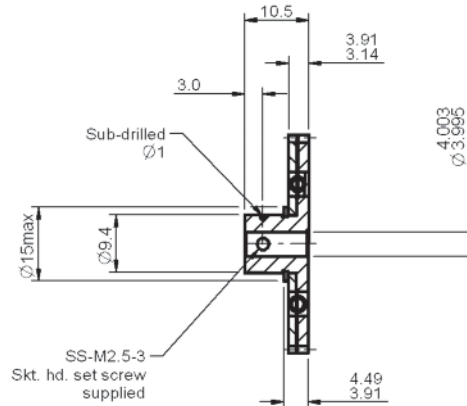

### Part number selection table

| Example Part No:- |                                      | <u>AP06S1B4F35A-</u> 65 |                 |     |
|-------------------|--------------------------------------|-------------------------|-----------------|-----|
| Standard Modules  | Basic Part Number Standard Materials |                         | Number of Teeth |     |
|                   | Stainless Steel                      | Aluminium Alloy         | Min             | Max |
| 1.5               | AP150S1B4F35A-                       | AP150A1B4F35A-          | 24              | 46  |
| 1.25              | AP125S1B4F35A-                       | AP125A1B4F35A-          | 28              | 56  |
| 1.0               | AP10S1B4F35A-                        | AP10A1B4F35A-           | 34              | 70  |
| 0.8               | AP08S1B4F35A-                        | AP08A1B4F35A-           | 42              | 88  |
| 0.6               | AP06S1B4F35A-                        | AP06A1B4F35A-           | 55              | 119 |
| 0.5               | AP05S1B4F35A-                        | AP05A1B4F35A-           | 66              | 143 |
| 0.4               | AP04S1B4F35A-                        | AP04A1B4F35A-           | 81              | 179 |
| 0.3               | AP03S1B4F35A-                        | AP03A1B4F35A-           | 107             | 240 |
| 0.25              | AP025S1B4F35A-                       | AP025A1B4F35A-          | 128             | 289 |
| 0.2               | AP02S1B4F35A-                        | AP02A1B4F35A-           | 159             | 361 |

### **i** Features and options

- Gear quality AQ10 as standard - see page T4-1
- Gear quality AQ9 for 1.5 mod
- Higher gear qualities available - see page T4-1
- Imperial gears available
- For all gear types and options - see page 4-6
- Product overview - see pages 4-2 to 4-6

### **?** Technical support

- Material specifications - see page T4-4
- Lubrication - see page T4-10
- Installation information - see page T4-9
- Treatment specifications - see page T4-4
- Technical information - see pages T4-1 to T4-18
- For modified or fully bespoke gear solutions, please contact us

Precision Gears





All dimensions in mm  
 General tolerances  $\pm 0.13$  mm  
 Pressure angle 20°

**Associated Products**  
 Clamp hub gears: page 4-36 to 4-50  
 Shafts: page 11-2  
 Bearings: page 12-1  
 Gear clamps: page 11-4

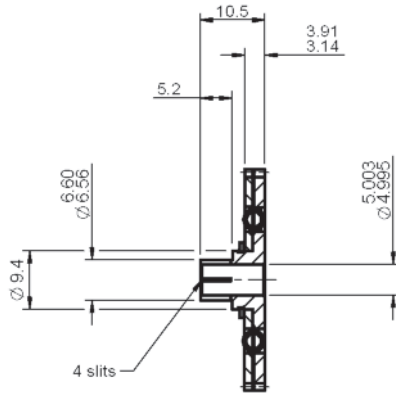

## Part number selection table

| Example Part No:- |   | <u>AC06S1B5F35A-</u> 65 |                 |     |
|-------------------|---|-------------------------|-----------------|-----|
| Standard Modules  | Basic Part Number<br>Standard Materials |                         | Number of Teeth |     |
|                   | Stainless Steel                         | Aluminium Alloy         | Min             | Max |
| 1.5               | AC150S1B5F35A-                          | AC150A1B5F35A-          | 24              | 46  |
| 1.25              | AC125S1B5F35A-                          | AC125A1B5F35A-          | 28              | 56  |
| 1.0               | AC10S1B5F35A-                           | AC10A1B5F35A-           | 34              | 70  |
| 0.8               | AC08S1B5F35A-                           | AC08A1B5F35A-           | 42              | 88  |
| 0.6               | AC06S1B5F35A-                           | AC06A1B5F35A-           | 55              | 119 |
| 0.5               | AC05S1B5F35A-                           | AC05A1B5F35A-           | 66              | 143 |
| 0.4               | AC04S1B5F35A-                           | AC04A1B5F35A-           | 81              | 179 |
| 0.3               | AC03S1B5F35A-                           | AC03A1B5F35A-           | 107             | 240 |
| 0.25              | AC025S1B5F35A-                          | AC025A1B5F35A-          | 128             | 289 |
| 0.2               | AC02S1B5F35A-                           | AC02A1B5F35A-           | 159             | 361 |

Precision Gears

### **i** Features and options

- Gear quality AQ10 as standard - see page T4-1
- Gear quality AQ9 for 1.5 mod
- Higher gear qualities available - see page T4-1
- Imperial gears available
- For all gear types and options - see page 4-6
- Product overview - see pages 4-2 to 4-6

### **?** Technical support

- Material specifications - see page T4-4
- Lubrication - see page T4-10
- Installation information - see page T4-9
- Treatment specifications - see page T4-4
- Technical information - see pages T4-1 to T4-18
- For modified or fully bespoke gear solutions, please contact us



### Associated Products

Pin hub gears: page 4-37 to 4-51  
 Shafts: page 11-2  
 Bearings: page 12-1  
 Pins: page 13-18

All dimensions in mm  
 General tolerances  $\pm 0.13$  mm  
 Pressure angle 20°

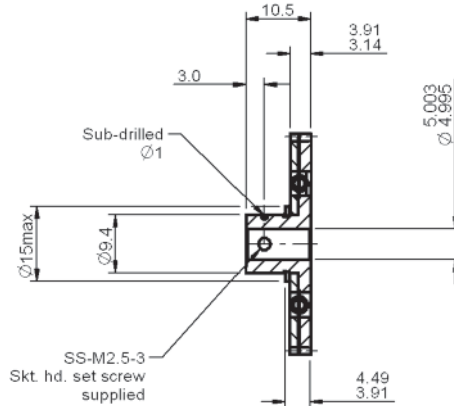

### Part number selection table

| Example Part No:- |                                      | <u>AP06S1B5F35A-</u> 65 |                 |     |
|-------------------|--------------------------------------|-------------------------|-----------------|-----|
| Standard Modules  | Basic Part Number Standard Materials |                         | Number of Teeth |     |
|                   | Stainless Steel                      | Aluminium Alloy         | Min             | Max |
| 1.5               | AP150S1B5F35A-                       | AP150A1B5F35A-          | 24              | 46  |
| 1.25              | AP125S1B5F35A-                       | AP125A1B5F35A-          | 28              | 56  |
| 1.0               | AP10S1B5F35A-                        | AP10A1B5F35A-           | 34              | 70  |
| 0.8               | AP08S1B5F35A-                        | AP08A1B5F35A-           | 42              | 88  |
| 0.6               | AP06S1B5F35A-                        | AP06A1B5F35A-           | 55              | 119 |
| 0.5               | AP05S1B5F35A-                        | AP05A1B5F35A-           | 66              | 143 |
| 0.4               | AP04S1B5F35A-                        | AP04A1B5F35A-           | 81              | 179 |
| 0.3               | AP03S1B5F35A-                        | AP03A1B5F35A-           | 107             | 240 |
| 0.25              | AP025S1B5F35A-                       | AP025A1B5F35A-          | 128             | 289 |
| 0.2               | AP02S1B5F35A-                        | AP02A1B5F35A-           | 159             | 361 |

### Features and options

- Gear quality AQ10 as standard - see page T4-1
- Gear quality AQ9 for 1.5 mod
- Higher gear qualities available - see page T4-1
- Imperial gears available
- For all gear types and options - see page 4-6
- Product overview - see pages 4-2 to 4-6

### Technical support

- Material specifications - see page T4-4
- Lubrication - see page T4-10
- Installation information - see page T4-9
- Treatment specifications - see page T4-4
- Technical information - see pages T4-1 to T4-18
- For modified or fully bespoke gear solutions, please contact us

Precision Gears



All dimensions in mm  
 General tolerances  $\pm 0.13$  mm  
 Pressure angle 20°

**Associated Products**  
 Clamp hub gears: page 4-36 to 4-50  
 Shafts: page 11-2  
 Bearings: page 12-1  
 Gear clamps: page 11-4

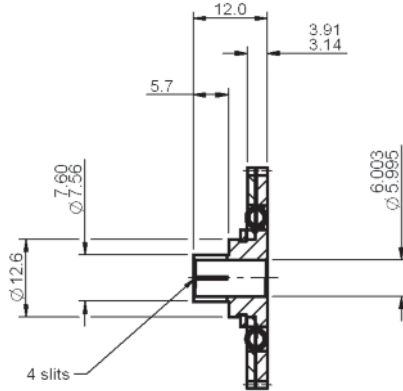

Part number selection table

| Example Part No:- |                                      | <u>AC06S1B6F35A-</u> 65 |                 |     |
|-------------------|--------------------------------------|-------------------------|-----------------|-----|
| Standard Modules  | Basic Part Number Standard Materials |                         | Number of Teeth |     |
|                   | Stainless Steel                      | Aluminium Alloy         | Min             | Max |
| 1.5               | AC150S1B6F35A-                       | AC150A1B6F35A-          | 24              | 46  |
| 1.25              | AC125S1B6F35A-                       | AC125A1B6F35A-          | 28              | 56  |
| 1.0               | AC10S1B6F35A-                        | AC10A1B6F35A-           | 34              | 70  |
| 0.8               | AC08S1B6F35A-                        | AC08A1B6F35A-           | 42              | 88  |
| 0.6               | AC06S1B6F35A-                        | AC06A1B6F35A-           | 55              | 119 |
| 0.5               | AC05S1B6F35A-                        | AC05A1B6F35A-           | 66              | 143 |
| 0.4               | AC04S1B6F35A-                        | AC04A1B6F35A-           | 81              | 179 |
| 0.3               | AC03S1B6F35A-                        | AC03A1B6F35A-           | 107             | 240 |
| 0.25              | AC025S1B6F35A-                       | AC025A1B6F35A-          | 128             | 289 |
| 0.2               | AC02S1B6F35A-                        | AC02A1B6F35A-           | 159             | 361 |

Precision Gears

**i Features and options**

- Gear quality AQ10 as standard - see page T4-1
- Gear quality AQ9 for 1.5 mod
- Higher gear qualities available - see page T4-1
- Imperial gears available
- For all gear types and options - see page 4-6
- Product overview - see pages 4-2 to 4-6

**? Technical support**

- Material specifications - see page T4-4
- Lubrication - see page T4-10
- Installation information - see page T4-9
- Treatment specifications - see page T4-4
- Technical information - see pages T4-1 to T4-18
- For modified or fully bespoke gear solutions, please contact us



### Associated Products

Pin hub gears: page 4-37 to 4-51  
 Shafts: page 11-2  
 Bearings: page 12-1  
 Pins: page 13-18

All dimensions in mm  
 General tolerances  $\pm 0.13$  mm  
 Pressure angle 20°

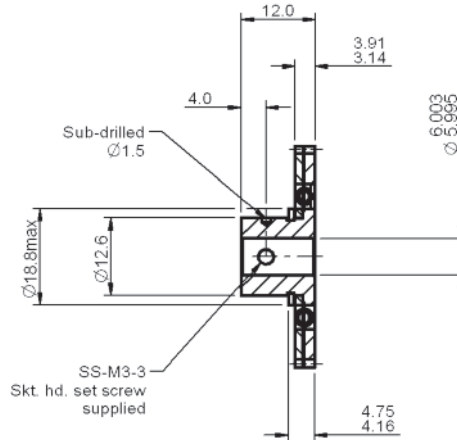

### Part number selection table

| Example Part No:- |                                      | <u>AP06S1B6F35A-</u> 65 |                 |     |
|-------------------|--------------------------------------|-------------------------|-----------------|-----|
| Standard Modules  | Basic Part Number Standard Materials |                         | Number of Teeth |     |
|                   | Stainless Steel                      | Aluminium Alloy         | Min             | Max |
| 1.5               | AP150S1B6F35A-                       | AP150A1B6F35A-          | 24              | 46  |
| 1.25              | AP125S1B6F35A-                       | AP125A1B6F35A-          | 28              | 56  |
| 1.0               | AP10S1B6F35A-                        | AP10A1B6F35A-           | 34              | 70  |
| 0.8               | AP08S1B6F35A-                        | AP08A1B6F35A-           | 42              | 88  |
| 0.6               | AP06S1B6F35A-                        | AP06A1B6F35A-           | 55              | 119 |
| 0.5               | AP05S1B6F35A-                        | AP05A1B6F35A-           | 66              | 143 |
| 0.4               | AP04S1B6F35A-                        | AP04A1B6F35A-           | 81              | 179 |
| 0.3               | AP03S1B6F35A-                        | AP03A1B6F35A-           | 107             | 240 |
| 0.25              | AP025S1B6F35A-                       | AP025A1B6F35A-          | 128             | 289 |
| 0.2               | AP02S1B6F35A-                        | AP02A1B6F35A-           | 159             | 361 |

### Features and options

- Gear quality AQ10 as standard - see page T4-1
- Gear quality AQ9 for 1.5 mod
- Higher gear qualities available - see page T4-1
- Imperial gears available
- For all gear types and options - see page 4-6
- Product overview - see pages 4-2 to 4-6

### Technical support

- Material specifications - see page T4-4
- Lubrication - see page T4-10
- Installation information - see page T4-9
- Treatment specifications - see page T4-4
- Technical information - see pages T4-1 to T4-18
- For modified or fully bespoke gear solutions, please contact us



All dimensions in mm  
 General tolerances  $\pm 0.13$  mm  
 Pressure angle  $20^\circ$

**Associated Products**  
 Clamp hub gears: page 4-36 to 4-50  
 Shafts: page 11-2  
 Bearings: page 12-1  
 Gear clamps: page 11-4

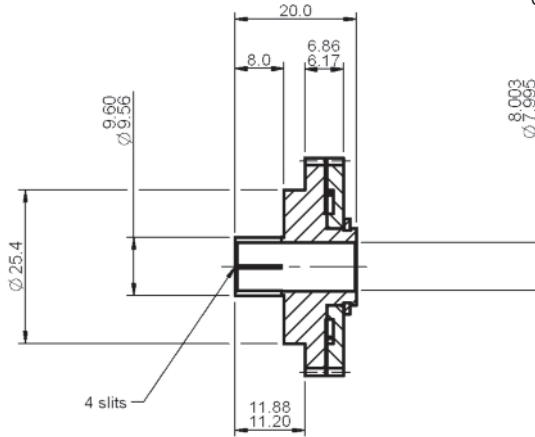

## Part number selection table

| Example Part No:- |   | <u>AC06S1B8F61A-</u> 90 |                 |     |
|-------------------|---|-------------------------|-----------------|-----|
| Standard Modules  | Basic Part Number<br>Standard Materials |                         | Number of Teeth |     |
|                   | Stainless Steel                         | Aluminium Alloy         | Min             | Max |
| 1.5               | AC150S1B8F61A-                          | AC150A1B8F61A-          | 21              | 75  |
| 1.25              | AC125S1B8F61A-                          | AC125A1B8F61A-          | 25              | 91  |
| 1.0               | AC10S1B8F61A-                           | AC10A1B8F61A-           | 30              | 114 |
| 0.8               | AC08S1B8F61A-                           | AC08A1B8F61A-           | 37              | 143 |
| 0.6               | AC06S1B8F61A-                           | AC06A1B8F61A-           | 48              | 192 |
| 0.5               | AC05S1B8F61A-                           | AC05A1B8F61A-           | 56              | 230 |
| 0.4               | AC04S1B8F61A-                           | AC04A1B8F61A-           | 70              | 289 |
| 0.3               | AC03S1B8F61A-                           | AC03A1B8F61A-           | 92              | 386 |
| 0.25              | AC025S1B8F61A-                          | AC025A1B8F61A-          | 110             | 463 |
| 0.2               | AC02S1B8F61A-                           | AC02A1B8F61A-           | 136             | 580 |

Precision Gears

### **i** Features and options

- Gear quality AQ10 as standard - see page T4-1
- Gear quality AQ9 for 1.5 mod
- Higher gear qualities available - see page T4-1
- Imperial gears available
- For all gear types and options - see page 4-6
- Product overview - see pages 4-2 to 4-6

### **?** Technical support

- Material specifications - see page T4-4
- Lubrication - see page T4-10
- Installation information - see page T4-9
- Treatment specifications - see page T4-4
- Technical information - see pages T4-1 to T4-18
- For modified or fully bespoke gear solutions, please contact us



### Associated Products

Pin hub gears: page 4-37 to 4-51  
 Shafts: page 11-1  
 Bearings: page 12-1  
 Pins: page 13-18

All dimensions in mm  
 General tolerances  $\pm 0.13$  mm  
 Pressure angle 20°

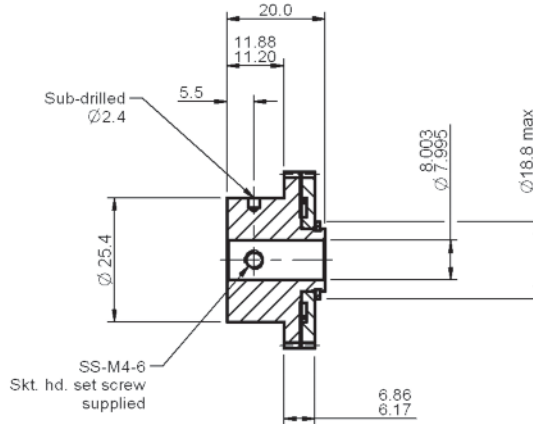

### Part number selection table

| Example Part No:- |                                      | <u>AP06S1B8F61A-</u> 90 |                 |     |
|-------------------|--------------------------------------|-------------------------|-----------------|-----|
| Standard Modules  | Basic Part Number Standard Materials |                         | Number of Teeth |     |
|                   | Stainless Steel                      | Aluminium Alloy         | Min             | Max |
| 1.5               | AP150S1B8F61A-                       | AP150A1B8F61A-          | 21              | 75  |
| 1.25              | AP125S1B8F61A-                       | AP125A1B8F61A-          | 25              | 91  |
| 1.0               | AP10S1B8F61A-                        | AP10A1B8F61A-           | 30              | 114 |
| 0.8               | AP08S1B8F61A-                        | AP08A1B8F61A-           | 37              | 143 |
| 0.6               | AP06S1B8F61A-                        | AP06A1B8F61A-           | 48              | 192 |
| 0.5               | AP05S1B8F61A-                        | AP05A1B8F61A-           | 56              | 230 |
| 0.4               | AP04S1B8F61A-                        | AP04A1B8F61A-           | 70              | 289 |
| 0.3               | AP03S1B8F61A-                        | AP03A1B8F61A-           | 92              | 386 |
| 0.25              | AP025S1B8F61A-                       | AP025A1B8F61A-          | 110             | 463 |
| 0.2               | AP02S1B8F61A-                        | AP02A1B8F61A-           | 136             | 580 |

### Features and options

- Gear quality AQ10 as standard - see page T4-1
- Gear quality AQ9 for 1.5 mod
- Higher gear qualities available - see page T4-1
- Imperial gears available
- For all gear types and options - see page 4-6
- Product overview - see pages 4-2 to 4-6

### Technical support

- Material specifications - see page T4-4
- Lubrication - see page T4-10
- Installation information - see page T4-9
- Treatment specifications - see page T4-4
- Technical information - see pages T4-1 to T4-18
- For modified or fully bespoke gear solutions, please contact us

Precision Gears



All dimensions in mm  
 General tolerances  $\pm 0.13\text{mm}$   
 Pressure angle  $20^\circ$

**Associated Products**  
 Clamp hub gears: page 4-36 to 4-50  
 Shafts: page 11-2  
 Bearings: page 12-1  
 Gear clamps: page 11-4

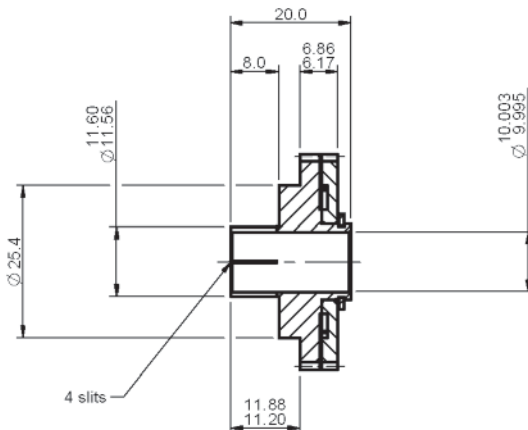

## Part number selection table

| Example Part No:- |   | <b>AC06S1B10F61A- 90</b> |                 |     |
|-------------------|---|--------------------------|-----------------|-----|
| Standard Modules  | Basic Part Number<br>Standard Materials |                          | Number of Teeth |     |
|                   | Stainless Steel                         | Aluminium Alloy          | Min             | Max |
| 1.5               | AC150S1B10F61A-                         | AC150A1B10F61A-          | 21              | 75  |
| 1.25              | AC125S1B10F61A-                         | AC125A1B10F61A-          | 25              | 91  |
| 1.0               | AC10S1B10F61A-                          | AC10A1B10F61A-           | 30              | 114 |
| 0.8               | AC08S1B10F61A-                          | AC08A1B10F61A-           | 37              | 143 |
| 0.6               | AC06S1B10F61A-                          | AC06A1B10F61A-           | 48              | 192 |
| 0.5               | AC05S1B10F61A-                          | AC05A1B10F61A-           | 56              | 230 |
| 0.4               | AC04S1B10F61A-                          | AC04A1B10F61A-           | 70              | 289 |
| 0.3               | AC03S1B10F61A-                          | AC03A1B10F61A-           | 92              | 386 |
| 0.25              | AC025S1B10F61A-                         | AC025A1B10F61A-          | 110             | 463 |
| 0.2               | AC02S1B10F61A-                          | AC02A1B10F61A-           | 136             | 580 |

Precision  
Gears

### **i** Features and options

- Gear quality AQ10 as standard - see page T4-1
- Gear quality AQ9 for 1.5 mod
- Higher gear qualities available - see page T4-1
- Imperial gears available
- For all gear types and options - see page 4-6
- Product overview - see pages 4-2 to 4-6

### **?** Technical support

- Material specifications - see page T4-4
- Lubrication - see page T4-10
- Installation information - see page T4-9
- Treatment specifications - see page T4-4
- Technical information - see pages T4-1 to T4-18
- For modified or fully bespoke gear solutions, please contact us





### Associated Products

Pin hub gears: page 4-37 to 4-51  
 Shafts: page 11-1  
 Bearings: page 12-1  
 Pins: page 13-18

All dimensions in mm  
 General tolerances  $\pm 0.13\text{mm}$   
 Pressure angle  $20^\circ$

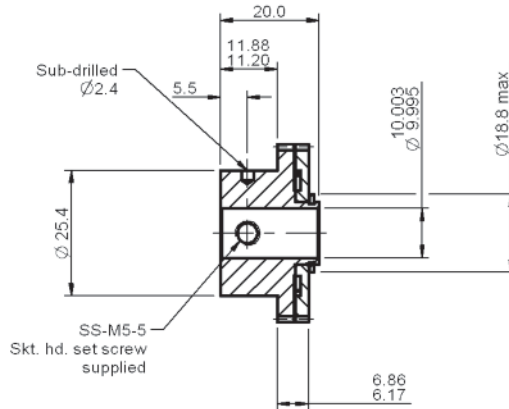

## Part number selection table

| Example Part No:- |   | <u>AP06S1B10F61A- 90</u> |                 |     |
|-------------------|---|--------------------------|-----------------|-----|
| Standard Modules  | Basic Part Number<br>Standard Materials |                          | Number of Teeth |     |
|                   | Stainless Steel                         | Aluminium Alloy          | Min             | Max |
| 1.5               | AP150S1B10F61A-                         | AP150A1B10F61A-          | 21              | 75  |
| 1.25              | AP125S1B10F61A-                         | AP125A1B10F61A-          | 25              | 91  |
| 1.0               | AP10S1B10F61A-                          | AP10A1B10F61A-           | 30              | 114 |
| 0.8               | AP08S1B10F61A-                          | AP08A1B10F61A-           | 37              | 143 |
| 0.6               | AP06S1B10F61A-                          | AP06A1B10F61A-           | 48              | 192 |
| 0.5               | AP05S1B10F61A-                          | AP05A1B10F61A-           | 56              | 230 |
| 0.4               | AP04S1B10F61A-                          | AP04A1B10F61A-           | 70              | 289 |
| 0.3               | AP03S1B10F61A-                          | AP03A1B10F61A-           | 92              | 386 |
| 0.25              | AP025S1B10F61A-                         | AP025A1B10F61A-          | 110             | 463 |
| 0.2               | AP02S1B10F61A-                          | AP02A1B10F61A-           | 136             | 580 |

### **i** Features and options

- Gear quality AQ10 as standard - see page T4-1
- Gear quality AQ9 for 1.5 mod
- Higher gear qualities available - see page T4-1
- Imperial gears available
- For all gear types and options - see page 4-6
- Product overview - see pages 4-2 to 4-6

### **?** Technical support

- Material specifications - see page T4-4
- Lubrication - see page T4-10
- Installation information - see page T4-9
- Treatment specifications - see page T4-4
- Technical information - see pages T4-1 to T4-18
- For modified or fully bespoke gear solutions, please contact us

Precision Gears



All dimensions in mm  
 General tolerances  $\pm 0.13$  mm  
 Pressure angle  $20^\circ$

**Associated Products**  
 Anti-backlash gears: page 4-7 to 4-34  
 Shafts: page 11-2  
 Bearings: page 12-1  
 Gear clamps: page 11-4

When F=2, L=7  
 F=4, L=9

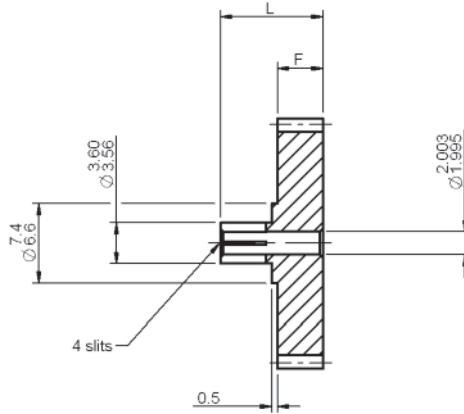

## Part number selection table

| Example Part No:- <u>C06S1B2</u> <u>F2A-</u> <u>25</u> |  |                 |                   |                 |     |     |
|--|--|-----------------|-------------------|-----------------|-----|-----|
| Standard Modules                                       | Basic Part Number Standard Materials # |                 | Face Width        | Number of Teeth |     |     |
|  | Stainless Steel                        | Aluminium Alloy |                   | Dim F           | Min | Max |
|  |  |                 | F2A               |                 |     | F4A |
| 1.5  | C150S1B2                               | C150A1B2        | F2A- (2 mm)       | 12 †            | 21  | 72  |
| 1.25   | C125S1B2                               | C125A1B2        |                   | 12 †            | 25  | 86  |
| 1.0  | C10S1B2                                | C10A1B2         |                   | 12 †            | 32  | 109 |
| 0.8  | C08S1B2                                | C08A1B2         |                   | 13 †            | 41  | 136 |
| 0.6  | C06S1B2                                | C06A1B2         | or<br>F4A- (4 mm) | 14 †            | 56  | 183 |
| 0.5  | C05S1B2                                | C05A1B2         |                   | 14 †            | 67  | 220 |
| 0.4  | C04S1B2                                | C04A1B2         |                   | 15 †            | 85  | 275 |
| 0.3  | C03S1B2                                | C03A1B2         |                   | 17              | 114 | 368 |
| 0.25   | C025S1B2                               | C025A1B2        | 18                | 137             | 442 |     |
| 0.2  | C02S1B2                                | C02A1B2         | 20                | 172             | 553 |     |

† Gears of 16 teeth or fewer will be modified - see page T4-8  
 # Alternative materials - replace **S1** in the part number with **B2** for brass

### **i** Features and options

- Gear quality AQ10 as standard - see page T4-1
- Gear quality AQ9 for 1.5 mod
- Higher gear qualities available - see page T4-1
- Imperial gears available
- For all gear types and options - see page 4-6
- Product overview - see pages 4-2 to 4-6

### **?** Technical support

- Material specifications - see page T4-4
- Lubrication - see page T4-10
- Installation information - see page T4-9
- Treatment specifications - see page T4-4
- Technical information - see pages T4-1 to T4-18
- For modified or fully bespoke gear solutions, please contact us



### Associated Products

Anti-backlash gears: page 4-13 to 4-35  
 Shafts: page 11-2  
 Bearings: page 12-1  
 Pins: page 13-18

All dimensions in mm  
 General tolerances  $\pm 0.13$  mm  
 Pressure angle  $20^\circ$

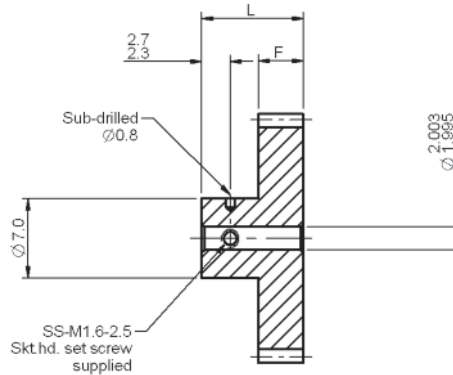

When  $F=2, L=7$   
 $F=4, L=9$

### Part number selection table

| Example Part No:- |   | <b>P06S1B2</b>  |                                  | <b>F2A-</b>     |     | <b>25</b> |  |
|-------------------|---|-----------------|----------------------------------|-----------------|-----|-----------|--|
| Standard Modules  | Basic Part Number<br>Standard Materials # |                 | Face Width                       | Number of Teeth |     |           |  |
|                   | Stainless Steel                           | Aluminium Alloy | Dim F                            | Min             | Max |           |  |
|                   |   |                 |                                  |                 | F2A | F4A       |  |
| 1.5               | <b>P150S1B2</b>                           | <b>P150A1B2</b> | F2A- (2 mm)<br>or<br>F4A- (4 mm) | 12 †            | 21  | 72        |  |
| 1.25              | <b>P125S1B2</b>                           | <b>P125A1B2</b> |                                  | 12 †            | 25  | 86        |  |
| 1.0               | <b>P10S1B2</b>                            | <b>P10A1B2</b>  |                                  | 12 †            | 32  | 109       |  |
| 0.8               | <b>P08S1B2</b>                            | <b>P08A1B2</b>  |                                  | 13 †            | 41  | 136       |  |
| 0.6               | <b>P06S1B2</b>                            | <b>P06A1B2</b>  |                                  | 15 †            | 56  | 183       |  |
| 0.5               | <b>P05S1B2</b>                            | <b>P05A1B2</b>  |                                  | 18              | 67  | 220       |  |
| 0.4               | <b>P04S1B2</b>                            | <b>P04A1B2</b>  |                                  | 21              | 85  | 275       |  |
| 0.3               | <b>P03S1B2</b>                            | <b>P03A1B2</b>  |                                  | 27              | 114 | 368       |  |
| 0.25              | <b>P025S1B2</b>                           | <b>P025A1B2</b> |                                  | 31              | 137 | 442       |  |
| 0.2               | <b>P02S1B2</b>                            | <b>P02A1B2</b>  |                                  | 38              | 172 | 553       |  |

† Gears of 16 teeth or fewer will be modified - see page T4-8

# Alternative materials - replace **S1** in the part number with **B2** for brass, or **S8** for hardened stainless steel

### Features and options

- Gear quality AQ10 as standard - see page T4-1
- Gear quality AQ9 for 1.5 mod
- Higher gear qualities available - see page T4-1
- Imperial gears available
- For all gear types and options - see page 4-6
- Product overview - see pages 4-2 to 4-6

### Technical support

- Material specifications - see page T4-4
- Lubrication - see page T4-10
- Installation information - see page T4-9
- Treatment specifications - see page T4-4
- Technical information - see pages T4-1 to T4-18
- For modified or fully bespoke gear solutions, please contact us

Precision Gears



All dimensions in mm  
 General tolerances  $\pm 0.13$  mm  
 Pressure angle  $20^\circ$

**Associated Products**  
 Anti-backlash gears: page 4-7 to 4-34  
 Shafts: page 11-2  
 Bearings: page 12-1  
 Gear clamps: page 11-4

When  $F=2, L=7$   
 $F=4, L=9$

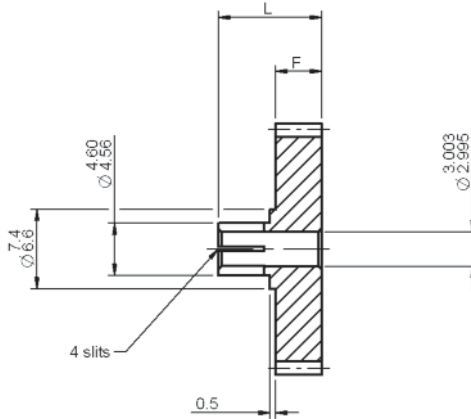

## Part number selection table

| Example Part No:- <b>C06S1B3 F2A- 25</b> |  |                 |                                   |                 |     |     |
|--|--|-----------------|-----------------------------------|-----------------|-----|-----|
| Standard Modules                         | Basic Part Number Standard Materials # |                 | Face Width<br>Dim F               | Number of Teeth |     |     |
|  | Stainless Steel                        | Aluminium Alloy |                                   | Min             | Max |     |
|  |  |                 | F2A                               |                 | F4A |     |
| 1.5                                      | C150S1B3                               | C150A1B3        | F2A- ( 2 mm)<br>or<br>F4A- (4 mm) | 12 †            | 21  | 72  |
| 1.25                                     | C125S1B3                               | C125A1B3        |                                   | 13 †            | 25  | 86  |
| 1.0                                      | C10S1B3                                | C10A1B3         |                                   | 13 †            | 32  | 109 |
| 0.8                                      | C08S1B3                                | C08A1B3         |                                   | 14 †            | 41  | 136 |
| 0.6                                      | C06S1B3                                | C06A1B3         |                                   | 15 †            | 56  | 183 |
| 0.5                                      | C05S1B3                                | C05A1B3         |                                   | 16 †            | 67  | 220 |
| 0.4                                      | C04S1B3                                | C04A1B3         |                                   | 18              | 85  | 275 |
| 0.3                                      | C03S1B3                                | C03A1B3         |                                   | 20              | 114 | 368 |
| 0.25                                     | C025S1B3                               | C025A1B3        |                                   | 22              | 137 | 442 |
| 0.2                                      | C02S1B3                                | C02A1B3         |                                   | 25              | 172 | 553 |

† Gears of 16 teeth or fewer will be modified - see page T4-8  
 # Alternative materials - replace **S1** in the part number with **B2** for brass

### **i** Features and options

- Gear quality AQ10 as standard - see page T4-1
- Gear quality AQ9 for 1.5 mod
- Higher gear qualities available - see page T4-1
- Imperial gears available
- For all gear types and options - see page 4-6
- Product overview - see pages 4-2 to 4-6

### **?** Technical support

- Material specifications - see page T4-4
- Lubrication - see page T4-10
- Installation information - see page T4-9
- Treatment specifications - see page T4-4
- Technical information - see pages T4-1 to T4-18
- For modified or fully bespoke gear solutions, please contact us



### Associated Products

Anti-backlash gears: page 4-13 to 4-35  
 Shafts: page 11-2  
 Bearings: page 12-1  
 Pins: page 13-18

All dimensions in mm  
 General tolerances  $\pm 0.13$  mm  
 Pressure angle 20°

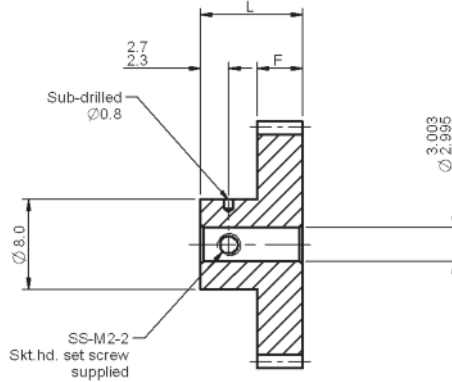

When F=2, L=7  
 F=4, L=9

### Part number selection table

| Example Part No:- <b>P06S1B3 F2A- 25</b> |  |                 |             |                 |     |     |
|--|--|-----------------|-------------|-----------------|-----|-----|
| Standard Modules                         | Basic Part Number Standard Materials # |                 | Face Width  | Number of Teeth |     |     |
|  | Stainless Steel                        | Aluminium Alloy | Dim F       | Min             | Max |     |
|  |  |                 |             |                 | F2A | F4A |
| 1.5                                      | <b>P150S1B3</b>                        | <b>P150A1B3</b> | F2A- (2 mm) | 12 †            | 21  | 72  |
| 1.25                                     | <b>P125S1B3</b>                        | <b>P125A1B3</b> |             | 13 †            | 25  | 86  |
| 1.0                                      | <b>P10S1B3</b>                         | <b>P10A1B3</b>  |             | 13 †            | 32  | 109 |
| 0.8                                      | <b>P08S1B3</b>                         | <b>P08A1B3</b>  |             | 14 †            | 41  | 136 |
| 0.6                                      | <b>P06S1B3</b>                         | <b>P06A1B3</b>  | or          | 17              | 56  | 183 |
| 0.5                                      | <b>P05S1B3</b>                         | <b>P05A1B3</b>  |             | 20              | 67  | 220 |
| 0.4                                      | <b>P04S1B3</b>                         | <b>P04A1B3</b>  | F4A- (4 mm) | 23              | 85  | 275 |
| 0.3                                      | <b>P03S1B3</b>                         | <b>P03A1B3</b>  |             | 30              | 114 | 368 |
| 0.25                                     | <b>P025S1B3</b>                        | <b>P025A1B3</b> |             | 35              | 137 | 442 |
| 0.2                                      | <b>P02S1B3</b>                         | <b>P02A1B3</b>  |             | 43              | 172 | 553 |

† Gears of 16 teeth or fewer will be modified - see page T4-8

# Alternative materials - replace **S1** in the part number with **B2** for brass, or **S8** for hardened stainless steel

### **i** Features and options

- Gear quality AQ10 as standard - see page T4-1
- Gear quality AQ9 for 1.5 mod
- Higher gear qualities available - see page T4-1
- Imperial gears available
- For all gear types and options - see page 4-6
- Product overview - see pages 4-2 to 4-6

### **?** Technical support

- Material specifications - see page T4-4
- Lubrication - see page T4-10
- Installation information - see page T4-9
- Treatment specifications - see page T4-4
- Technical information - see pages T4-1 to T4-18
- For modified or fully bespoke gear solutions, please contact us

Precision Gears



All dimensions in mm  
 General tolerances  $\pm 0.13$  mm  
 Pressure angle  $20^\circ$

**Associated Products**  
 Anti-backlash gears: page 4-7 to 4-34  
 Shafts: page 11-2  
 Bearings: page 12-1  
 Gear clamps: page 11-4

When F=2, L=9  
 F=4, L=11

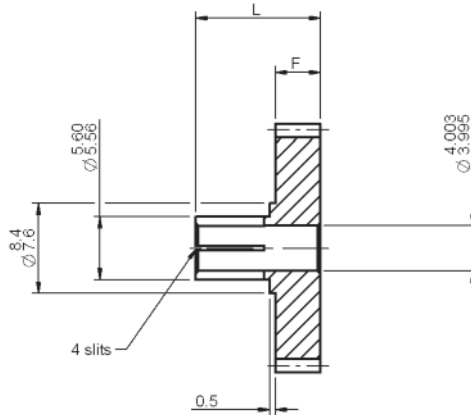

## Part number selection table

| Example Part No:- <u>C06S1B4</u> <u>F2A-</u> <u>25</u> |  |                 |             |                 |     |     |
|--|--|-----------------|-------------|-----------------|-----|-----|
| Standard Modules                                       | Basic Part Number Standard Materials # |                 | Face Width  | Number of Teeth |     |     |
|  | Stainless Steel                        | Aluminium Alloy | Dim F       | Min             | Max |     |
|  |  |                 |             |                 | F2A | F4A |
| 1.5  | C150S1B4                               | C150A1B4        | F2A- (2 mm) | 13 †            | 21  | 72  |
| 1.25   | C125S1B4                               | C125A1B4        |             | 14 †            | 25  | 86  |
| 1.0  | C10S1B4                                | C10A1B4         |             | 14 †            | 32  | 109 |
| 0.8  | C08S1B4                                | C08A1B4         |             | 15 †            | 41  | 136 |
| 0.6  | C06S1B4                                | C06A1B4         | or          | 17              | 56  | 183 |
| 0.5  | C05S1B4                                | C05A1B4         | F4A- (4 mm) | 18              | 67  | 220 |
| 0.4  | C04S1B4                                | C04A1B4         |             | 20              | 85  | 275 |
| 0.3  | C03S1B4                                | C03A1B4         |             | 24              | 114 | 368 |
| 0.25   | C025S1B4                               | C025A1B4        |             | 26              | 137 | 442 |
| 0.2  | C02S1B4                                | C02A1B4         |             | 30              | 172 | 553 |

† Gears of 16 teeth or fewer will be modified - see page T4-8  
 # Alternative materials - replace **S1** in the part number with **B2** for brass

### **i** Features and options

- Gear quality AQ10 as standard - see page T4-1
- Gear quality AQ9 for 1.5 mod
- Higher gear qualities available - see page T4-1
- Imperial gears available
- For all gear types and options - see page 4-6
- Product overview - see pages 4-2 to 4-6

### **?** Technical support

- Material specifications - see page T4-4
- Lubrication - see page T4-10
- Installation information - see page T4-9
- Treatment specifications - see page T4-4
- Technical information - see pages T4-1 to T4-18
- For modified or fully bespoke gear solutions, please contact us



### Associated Products

Anti-backlash gears: page 4-13 to 4-35  
 Shafts: page 11-2  
 Bearings: page 12-1  
 Pins: page 13-18

All dimensions in mm  
 General tolerances  $\pm 0.13$  mm  
 Pressure angle 20°

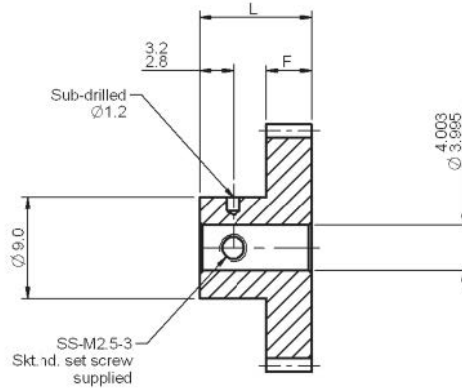

When F=2, L=8  
 F=4, L=10

### Part number selection table

| Example Part No:- |   | <b>P06S1B4</b>  | <b>F2A-</b> | <b>25</b>       |     |     |
|-------------------|---|-----------------|-------------|-----------------|-----|-----|
| Standard Modules  | Basic Part Number<br>Standard Materials # |                 | Face Width  | Number of Teeth |     |     |
|                   | Stainless Steel                           | Aluminium Alloy | Dim F       | Min             | Max |     |
|                   |   |                 |             |                 | F2A | F4A |
| 1.5               | <b>P150S1B4</b>                           | <b>P150A1B4</b> | F2A- (2 mm) | 13 †            | 21  | 72  |
| 1.25              | <b>P125S1B4</b>                           | <b>P125A1B4</b> |             | 14 †            | 25  | 86  |
| 1.0               | <b>P10S1B4</b>                            | <b>P10A1B4</b>  |             | 14 †            | 32  | 109 |
| 0.8               | <b>P08S1B4</b>                            | <b>P08A1B4</b>  |             | 15 †            | 41  | 136 |
| 0.6               | <b>P06S1B4</b>                            | <b>P06A1B4</b>  | or          | 19              | 56  | 183 |
| 0.5               | <b>P05S1B4</b>                            | <b>P05A1B4</b>  |             | F4A- (4 mm)     | 22  | 67  |
| 0.4               | <b>P04S1B4</b>                            | <b>P04A1B4</b>  | 26          |                 | 85  | 275 |
| 0.3               | <b>P03S1B4</b>                            | <b>P03A1B4</b>  | 34          |                 | 114 | 368 |
| 0.25              | <b>P025S1B4</b>                           | <b>P025A1B4</b> | 39          |                 | 137 | 442 |
| 0.2               | <b>P02S1B4</b>                            | <b>P02A1B4</b>  | 48          | 172             | 553 |     |

† Gears of 16 teeth or fewer will be modified - see page T4-8

# Alternative materials - replace **S1** in the part number with **B2** for brass, or **S8** for hardened stainless steel

### **i** Features and options

- Gear quality AQ10 as standard - see page T4-1
- Gear quality AQ9 for 1.5 mod
- Higher gear qualities available - see page T4-1
- Imperial gears available
- For all gear types and options - see page 4-6
- Product overview - see pages 4-2 to 4-6

### **?** Technical support

- Material specifications - see page T4-4
- Lubrication - see page T4-10
- Installation information - see page T4-9
- Treatment specifications - see page T4-4
- Technical information - see pages T4-1 to T4-18
- For modified or fully bespoke gear solutions, please contact us

Precision Gears



All dimensions in mm  
 General tolerances  $\pm 0.13$  mm  
 Pressure angle  $20^\circ$

**Associated Products**  
 Anti-backlash gears: page 4-7 to 4-34  
 Shafts: page 11-2  
 Bearings: page 12-1  
 Gear clamps: page 11-4

when F=2, L=9  
 F=4, L=11

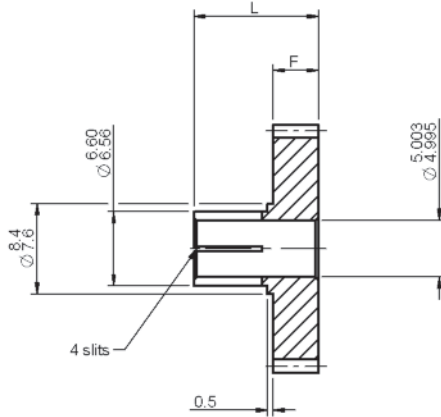

## Part number selection table

| Example Part No:- <b>C06S1B5 F2A- 25</b> |   |                 |             |                 |     |     |
|--|---|-----------------|-------------|-----------------|-----|-----|
| Standard Modules                         | Basic Part Number<br>Standard Materials # |                 | Face Width  | Number of Teeth |     |     |
|  | Stainless Steel                           | Aluminium Alloy | Dim F       | Min             | Max |     |
|  |   |                 |             |                 | F2A | F4A |
| 1.5                                      | C150S1B5                                  | C150A1B5        | F2A- (2 mm) | 14 †            | 21  | 72  |
| 1.25                                     | C125S1B5                                  | C125A1B5        |             | 14 †            | 25  | 86  |
| 1.0                                      | C10S1B5                                   | C10A1B5         | or          | 15 †            | 32  | 109 |
| 0.8                                      | C08S1B5                                   | C08A1B5         |             | 17              | 41  | 136 |
| 0.6                                      | C06S1B5                                   | C06A1B5         | F4A- (4 mm) | 19              | 56  | 183 |
| 0.5                                      | C05S1B5                                   | C05A1B5         |             | 20              | 67  | 220 |
| 0.4                                      | C04S1B5                                   | C04A1B5         | 23          | 85              | 275 |     |
| 0.3                                      | C03S1B5                                   | C03A1B5         | 27          | 114             | 368 |     |
| 0.25                                     | C025S1B5                                  | C025A1B5        | 30          | 137             | 442 |     |
| 0.2                                      | C02S1B5                                   | C02A1B5         | 35          | 172             | 553 |     |

† Gears of 16 teeth or fewer will be modified - see page T4-8  
 # Alternative materials - replace **S1** in the part number with **B2** for brass

### **i** Features and options

- Gear quality AQ10 as standard - see page T4-1
- Gear quality AQ9 for 1.5 mod
- Higher gear qualities available - see page T4-1
- Imperial gears available
- For all gear types and options - see page 4-6
- Product overview - see pages 4-2 to 4-6

### **?** Technical support

- Material specifications - see page T4-4
- Lubrication - see page T4-10
- Installation information - see page T4-9
- Treatment specifications - see page T4-4
- Technical information - see pages T4-1 to T4-18
- For modified or fully bespoke gear solutions, please contact us





### Associated Products

Anti-backlash gears: page 4-13 to 4-35  
 Shafts: page 11-2  
 Bearings: page 12-1  
 Pins: page 13-18

All dimensions in mm  
 General tolerances  $\pm 0.13$  mm  
 Pressure angle 20°

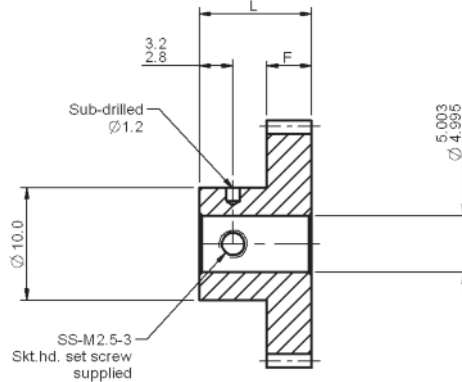

when F=2, L=8  
 F=4, L=10

## Part number selection table

| Example Part No:- |   | <b>P06S1B5</b>  | <b>F2A-</b> | <b>25</b>       |     |     |
|-------------------|---|-----------------|-------------|-----------------|-----|-----|
| Standard Modules  | Basic Part Number<br>Standard Materials # |                 | Face Width  | Number of Teeth |     |     |
|                   | Stainless Steel                           | Aluminium Alloy | Dim F       | Min             | Max |     |
|                   |   |                 |             |                 | F2A | F4A |
| 1.5               | <b>P150S1B5</b>                           | <b>P150A1B5</b> | F2A- (2 mm) | 14 †            | 21  | 72  |
| 1.25              | <b>P125S1B5</b>                           | <b>P125A1B5</b> |             | 14 †            | 25  | 86  |
| 1.0               | <b>P10S1B5</b>                            | <b>P10A1B5</b>  |             | 15 †            | 32  | 109 |
| 0.8               | <b>P08S1B5</b>                            | <b>P08A1B5</b>  |             | 17              | 41  | 136 |
| 0.6               | <b>P06S1B5</b>                            | <b>P06A1B5</b>  | or          | 21              | 56  | 183 |
| 0.5               | <b>P05S1B5</b>                            | <b>P05A1B5</b>  |             | 24              | 67  | 220 |
| 0.4               | <b>P04S1B5</b>                            | <b>P04A1B5</b>  | F4A- (4 mm) | 29              | 85  | 275 |
| 0.3               | <b>P03S1B5</b>                            | <b>P03A1B5</b>  |             | 37              | 114 | 368 |
| 0.25              | <b>P025S1B5</b>                           | <b>P025A1B5</b> |             | 43              | 137 | 442 |
| 0.2               | <b>P02S1B5</b>                            | <b>P02A1B5</b>  |             | 53              | 172 | 553 |

† Gears of 16 teeth or fewer will be modified - see page T4-8

# Alternative materials - replace **S1** in the part number with **B2** for brass, or **S8** for hardened stainless steel

### **i** Features and options

- Gear quality AQ10 as standard - see page T4-1
- Gear quality AQ9 for 1.5 mod
- Higher gear qualities available - see page T4-1
- Imperial gears available
- For all gear types and options - see page 4-6
- Product overview - see pages 4-2 to 4-6

### **?** Technical support

- Material specifications - see page T4-4
- Lubrication - see page T4-10
- Installation information - see page T4-9
- Treatment specifications - see page T4-4
- Technical information - see pages T4-1 to T4-18
- For modified or fully bespoke gear solutions, please contact us

Precision Gears



All dimensions in mm  
 General tolerances  $\pm 0.13$  mm  
 Pressure angle  $20^\circ$

**Associated Products**  
 Anti-backlash gears: page 4-7 to 4-34  
 Shafts: page 11-2  
 Bearings: page 12-1  
 Gear clamps: page 11-4

When F=3, L=10  
 F=4, L=11  
 F=6, L=13

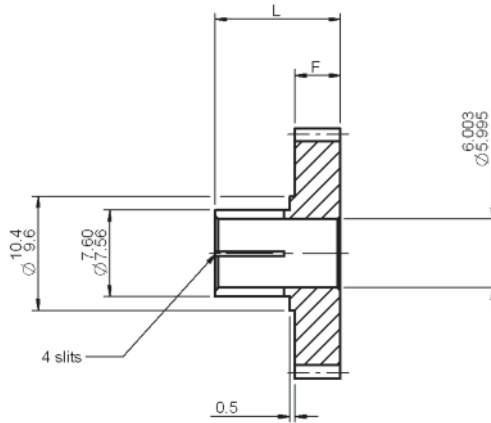

## Part number selection table

| Example Part No:- <u>C06S1B6</u> <u>F3A-</u> <u>75</u> |   |                 |             |                 |     |
|--|---|-----------------|-------------|-----------------|-----|
| Standard Modules                                       | Basic Part Number<br>Standard Materials # |                 | Face Width  | Number of Teeth |     |
|  | Stainless Steel                           | Aluminium Alloy | Dim F       | Min             | Max |
| 1.5  | C150S1B6                                  | C150A1B6        | F3A- (3 mm) | 14 †            | 72  |
| 1.25   | C125S1B6                                  | C125A1B6        |             | 15 †            | 86  |
| 1.0  | C10S1B6                                   | C10A1B6         | or          | 16 †            | 109 |
| 0.8  | C08S1B6                                   | C08A1B6         |             | 18              | 136 |
| 0.6  | C06S1B6                                   | C06A1B6         | F4A- (4 mm) | 20              | 183 |
| 0.5  | C05S1B6                                   | C05A1B6         |             | 22              | 220 |
| 0.4  | C04S1B6                                   | C04A1B6         | or          | 25              | 275 |
| 0.3  | C03S1B6                                   | C03A1B6         |             | 30              | 368 |
| 0.25   | C025S1B6                                  | C025A1B6        | F6A- (6 mm) | 34              | 442 |
| 0.2  | C02S1B6                                   | C02A1B6         |             | 40              | 553 |

† Gears of 16 teeth or fewer will be modified - see page T4-8  
 # Alternative materials - replace **S1** in the part number with **B2** for brass

### Features and options

- Gear quality AQ10 as standard - see page T4-1
- Gear quality AQ9 for 1.5 mod
- Higher gear qualities available - see page T4-1
- Imperial gears available
- For all gear types and options - see page 4-6
- Product overview - see pages 4-2 to 4-6

### Technical support

- Material specifications - see page T4-4
- Lubrication - see page T4-10
- Installation information - see page T4-9
- Treatment specifications - see page T4-4
- Technical information - see pages T4-1 to T4-18
- For modified or fully bespoke gear solutions, please contact us



### Associated Products

Anti-backlash gears: page 4-13 to 4-35  
 Shafts: page 11-2  
 Bearings: page 12-1  
 Pins: page 13-18

All dimensions in mm  
 General tolerances  $\pm 0.13$  mm  
 Pressure angle 20°

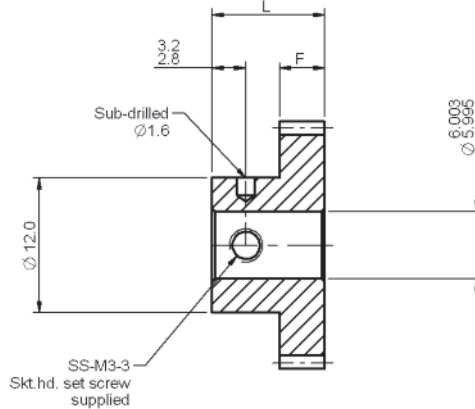

When F=3, L=9  
 F=4, L=10  
 F=6, L=12

### Part number selection table

| Example Part No:- |   | <b>P06S1B6</b>  | <b>F3A-</b>        | <b>75</b>       |     |  |
|-------------------|---|-----------------|--------------------|-----------------|-----|--|
| Standard Modules  | Basic Part Number<br>Standard Materials # |                 | Face Width         | Number of Teeth |     |  |
|                   | Stainless Steel                           | Aluminium Alloy | Dim F              | Min             | Max |  |
| 1.5               | <b>P150S1B6</b>                           | <b>P150A1B6</b> | <b>F3A-</b> (3 mm) | 14 †            | 72  |  |
| 1.25              | <b>P125S1B6</b>                           | <b>P125A1B6</b> |                    | 15 †            | 86  |  |
| 1.0               | <b>P10S1B6</b>                            | <b>P10A1B6</b>  | or                 | 16 †            | 109 |  |
| 0.8               | <b>P08S1B6</b>                            | <b>P08A1B6</b>  | <b>F4A-</b> (4 mm) | 19              | 136 |  |
| 0.6               | <b>P06S1B6</b>                            | <b>P06A1B6</b>  |                    | 23              | 183 |  |
| 0.5               | <b>P05S1B6</b>                            | <b>P05A1B6</b>  |                    | 27              | 220 |  |
| 0.4               | <b>P04S1B6</b>                            | <b>P04A1B6</b>  | or                 | 33              | 275 |  |
| 0.3               | <b>P03S1B6</b>                            | <b>P03A1B6</b>  | <b>F6A-</b> (6 mm) | 43              | 368 |  |
| 0.25              | <b>P025S1B6</b>                           | <b>P025A1B6</b> |                    | 50              | 442 |  |
| 0.2               | <b>P02S1B6</b>                            | <b>P02A1B6</b>  |                    | 62              | 553 |  |

† Gears of 16 teeth or fewer will be modified - see page T4-8

# Alternative materials - replace **S1** in the part number with **B2** for brass, or **S8** for hardened stainless steel

### **i** Features and options

- Gear quality AQ10 as standard - see page T4-1
- Gear quality AQ9 for 1.5 mod
- Higher gear qualities available - see page T4-1
- Imperial gears available
- For all gear types and options - see page 4-6
- Product overview - see pages 4-2 to 4-6

### **?** Technical support

- Material specifications - see page T4-4
- Lubrication - see page T4-10
- Installation information - see page T4-9
- Treatment specifications - see page T4-4
- Technical information - see pages T4-1 to T4-18
- For modified or fully bespoke gear solutions, please contact us

Precision Gears



All dimensions in mm  
 General tolerances  $\pm 0.13$  mm  
 Pressure angle  $20^\circ$

**Associated Products**  
 Anti-backlash gears: page 4-7 to 4-34  
 Shafts: page 11-2  
 Bearings: page 12-1  
 Gear clamps: page 11-4

When F=4, L=13  
 F=6, L=15

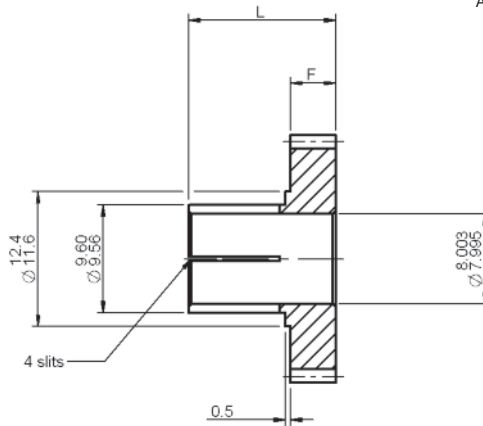

## Part number selection table

Example Part No:- **C06S1B8 F4A- 75**

| Standard Modules | Basic Part Number<br>Standard Materials # |                 | Face Width                       | Number of Teeth |     |
|------------------|---|-----------------|----------------------------------|-----------------|-----|
|                  | Stainless Steel                           | Aluminium Alloy | Dim F                            | Min             | Max |
| 1.5              | C150S1B8                                  | C150A1B8        | F4A- (4 mm)<br>or<br>F6A- (6 mm) | 16 †            | 72  |
| 1.25             | C125S1B8                                  | C125A1B8        |                                  | 17              | 86  |
| 1.0              | C10S1B8                                   | C10A1B8         |                                  | 18              | 109 |
| 0.8              | C08S1B8                                   | C08A1B8         |                                  | 20              | 136 |
| 0.6              | C06S1B8                                   | C06A1B8         |                                  | 24              | 183 |
| 0.5              | C05S1B8                                   | C05A1B8         |                                  | 26              | 220 |
| 0.4              | C04S1B8                                   | C04A1B8         | 30                               | 275             |     |
| 0.3              | C03S1B8                                   | C03A1B8         | 37                               | 368             |     |
| 0.25             | C025S1B8                                  | C025A1B8        | 42                               | 442             |     |
| 0.2              | C02S1B8                                   | C02A1B8         | 50                               | 553             |     |

† Gears of 16 teeth will be modified - see page T4-8

# Alternative materials - replace **S1** in the part number with **B2** for brass

### Features and options

- Gear quality AQ10 as standard - see page T4-1
- Gear quality AQ9 for 1.5 mod
- Higher gear qualities available - see page T4-1
- Imperial gears available
- For all gear types and options - see page 4-6
- Product overview - see pages 4-2 to 4-6

### Technical support

- Material specifications - see page T4-4
- Lubrication - see page T4-10
- Installation information - see page T4-9
- Treatment specifications - see page T4-4
- Technical information - see pages T4-1 to T4-18
- For modified or fully bespoke gear solutions, please contact us



### Associated Products

Anti-backlash gears: page 4-13 to 4-35  
 Shafts: page 11-2  
 Bearings: page 12-1  
 Pins: page 13-18

All dimensions in mm  
 General tolerances  $\pm 0.13$  mm  
 Pressure angle 20°

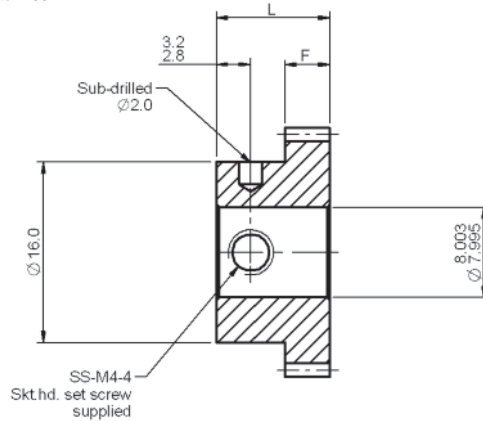

When F=4, L=10  
 F=6, L=12

### Part number selection table

| Example Part No:- |   | <b>P06S1B8</b>  |                                  | <b>F4A-</b>     | <b>75</b> |
|-------------------|---|-----------------|----------------------------------|-----------------|-----------|
| Standard Modules  | Basic Part Number<br>Standard Materials # |                 | Face Width                       | Number of Teeth |           |
|                   | Stainless Steel                           | Aluminium Alloy | Dim F                            | Min             | Max       |
| 1.5               | <b>P150S1B8</b>                           | <b>P150A1B8</b> | F4A- (4 mm)<br>or<br>F6A- (6 mm) | 16 †            | 72        |
| 1.25              | <b>P125S1B8</b>                           | <b>P125A1B8</b> |                                  | 17              | 86        |
| 1.0               | <b>P10S1B8</b>                            | <b>P10A1B8</b>  |                                  | 20              | 109       |
| 0.8               | <b>P08S1B8</b>                            | <b>P08A1B8</b>  |                                  | 24              | 136       |
| 0.6               | <b>P06S1B8</b>                            | <b>P06A1B8</b>  |                                  | 30              | 183       |
| 0.5               | <b>P05S1B8</b>                            | <b>P05A1B8</b>  |                                  | 35              | 220       |
| 0.4               | <b>P04S1B8</b>                            | <b>P04A1B8</b>  | F6A- (6 mm)                      | 43              | 275       |
| 0.3               | <b>P03S1B8</b>                            | <b>P03A1B8</b>  |                                  | 56              | 368       |
| 0.25              | <b>P025S1B8</b>                           | <b>P025A1B8</b> |                                  | 66              | 442       |
| 0.2               | <b>P02S1B8</b>                            | <b>P02A1B8</b>  |                                  | 82              | 553       |

† Gears of 16 teeth will be modified - see page T4-8

# Alternative materials - replace **S1** in the part number with **B2** for brass, or **S8** for hardened stainless steel

### **i** Features and options

- Gear quality AQ10 as standard - see page T4-1
- Gear quality AQ9 for 1.5 mod
- Higher gear qualities available - see page T4-1
- Imperial gears available
- For all gear types and options - see page 4-6
- Product overview - see pages 4-2 to 4-6

### **?** Technical support

- Material specifications - see page T4-4
- Lubrication - see page T4-10
- Installation information - see page T4-9
- Treatment specifications - see page T4-4
- Technical information - see pages T4-1 to T4-18
- For modified or fully bespoke gear solutions, please contact us

Precision Gears



All dimensions in mm  
 General tolerances  $\pm 0.13$  mm  
 Pressure angle  $20^\circ$

**Associated Products**  
 Anti-backlash gears: page 4-7 to 4-34  
 Shafts: page 11-2  
 Bearings: page 12-1  
 Gear clamps: page 11-4

When  $F=4, L=13$   
 $F=6, L=15$

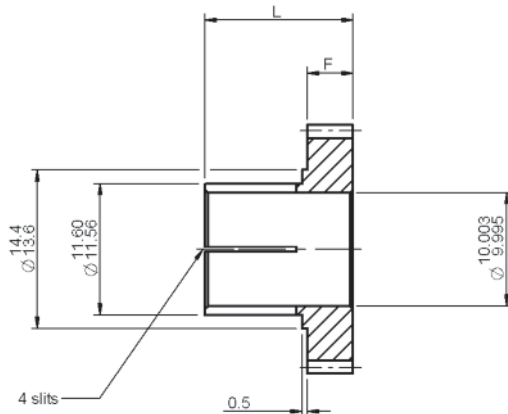

## Part number selection table

| Example Part No:- <u>C06S1B10</u> <u>F4A-</u> <u>75</u> |   |                  |             |                 |     |
|---|---|------------------|-------------|-----------------|-----|
| Standard Modules  | Basic Part Number<br>Standard Materials # |                  | Face Width  | Number of Teeth |     |
|   | Stainless Steel                           | Aluminium Alloy  | Dim F       | Min             | Max |
| 1.5   | <b>C150S1B10</b>                          | <b>C150A1B10</b> | F4A- (4 mm) | 17              | 72  |
| 1.25  | <b>C125S1B10</b>                          | <b>C125A1B10</b> |             | 18              | 86  |
| 1.0   | <b>C10S1B10</b>                           | <b>C10A1B10</b>  | or          | 20              | 109 |
| 0.8   | <b>C08S1B10</b>                           | <b>C08A1B10</b>  |             | 23              | 136 |
| 0.6   | <b>C06S1B10</b>                           | <b>C06A1B10</b>  | F6A- (6 mm) | 27              | 183 |
| 0.5   | <b>C05S1B10</b>                           | <b>C05A1B10</b>  |             | 30              | 220 |
| 0.4   | <b>C04S1B10</b>                           | <b>C04A1B10</b>  | F6A- (6 mm) | 35              | 275 |
| 0.3   | <b>C03S1B10</b>                           | <b>C03A1B10</b>  |             | 44              | 368 |
| 0.25  | <b>C025S1B10</b>                          | <b>C025A1B10</b> | 50          | 442             |     |
| 0.2   | <b>C02S1B10</b>                           | <b>C02A1B10</b>  | 60          | 553             |     |

# Alternative materials - replace **S1** in the part number with **B2** for brass

### **i** Features and options

- Gear quality AQ10 as standard - see page T4-1
- Gear quality AQ9 for 1.5 mod
- Higher gear qualities available - see page T4-1
- Imperial gears available
- For all gear types and options - see page 4-6
- Product overview - see pages 4-2 to 4-6

### **?** Technical support

- Material specifications - see page T4-4
- Lubrication - see page T4-10
- Installation information - see page T4-9
- Treatment specifications - see page T4-4
- Technical information - see pages T4-1 to T4-18
- For modified or fully bespoke gear solutions, please contact us



### Associated Products

Anti-backlash gears: page 4-13 to 4-35  
 Shafts: page 11-2  
 Bearings: page 12-1  
 Pins: page 13-18

All dimensions in mm  
 General tolerances  $\pm 0.13$  mm  
 Pressure angle 20°

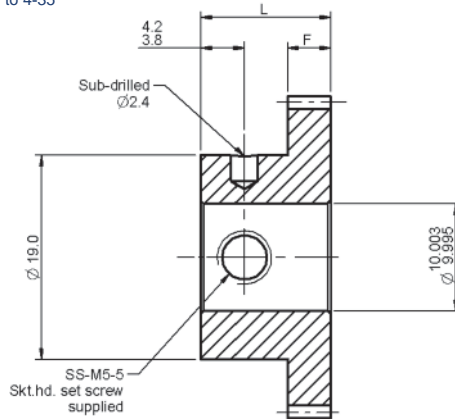

When F=4, L=12  
 F=6, L=14

## Part number selection table

| Example Part No:- |   | <b>P06S1B10</b>  | <b>F4A-</b>                      | <b>75</b>       |            |
|-------------------|---|------------------|----------------------------------|-----------------|------------|
| Standard Modules  | Basic Part Number<br>Standard Materials # |                  | Face Width                       | Number of Teeth |            |
|                   | Stainless Steel                           | Aluminium Alloy  | Dim F                            | Min             | Max        |
| 1.5               | <b>P150S1B10</b>                          | <b>P150A1B10</b> | F4A- (4 mm)<br>or<br>F6A- (6 mm) | <b>17</b>       | <b>72</b>  |
| 1.25              | <b>P125S1B10</b>                          | <b>P125A1B10</b> |                                  | <b>19</b>       | <b>86</b>  |
| 1.0               | <b>P10S1B10</b>                           | <b>P10A1B10</b>  |                                  | <b>22</b>       | <b>109</b> |
| 0.8               | <b>P08S1B10</b>                           | <b>P08A1B10</b>  |                                  | <b>27</b>       | <b>136</b> |
| 0.6               | <b>P06S1B10</b>                           | <b>P06A1B10</b>  |                                  | <b>34</b>       | <b>183</b> |
| 0.5               | <b>P05S1B10</b>                           | <b>P05A1B10</b>  |                                  | <b>40</b>       | <b>220</b> |
| 0.4               | <b>P04S1B10</b>                           | <b>P04A1B10</b>  |                                  | <b>50</b>       | <b>275</b> |
| 0.3               | <b>P03S1B10</b>                           | <b>P03A1B10</b>  |                                  | <b>65</b>       | <b>368</b> |
| 0.25              | <b>P025S1B10</b>                          | <b>P025A1B10</b> |                                  | <b>77</b>       | <b>442</b> |
| 0.2               | <b>P02S1B10</b>                           | <b>P02A1B10</b>  |                                  | <b>95</b>       | <b>553</b> |

# Alternative materials - replace **S1** in the part number with **B2** for brass, or **S8** for hardened stainless steel

### **i** Features and options

- Gear quality AQ10 as standard - see page T4-1
- Gear quality AQ9 for 1.5 mod
- Higher gear qualities available - see page T4-1
- Imperial gears available
- For all gear types and options - see page 4-6
- Product overview - see pages 4-2 to 4-6

### **?** Technical support

- Material specifications - see page T4-4
- Lubrication - see page T4-10
- Installation information - see page T4-9
- Treatment specifications - see page T4-4
- Technical information - see pages T4-1 to T4-18
- For modified or fully bespoke gear solutions, please contact us

Precision Gears



All dimensions in mm  
 General tolerances  $\pm 0.13$  mm  
 Pressure angle  $20^\circ$

**Associated Products**  
 Anti-backlash gears: page 4-7 to 4-34  
 Shafts: page 11-2  
 Bearings: page 12-1  
 Gear clamps: page 11-4

When  $F=6, L=15$   
 $F=10, L=19$

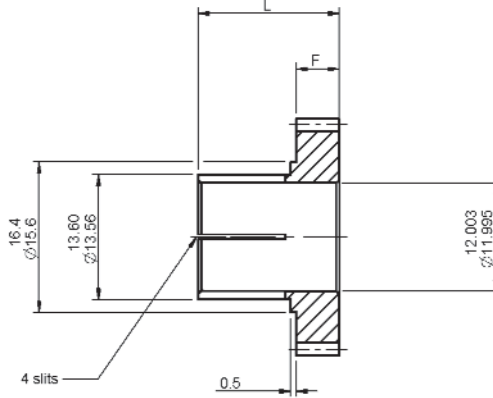

## Part number selection table

| Example Part No:- <u>C06S1B12</u> <u>F6A-</u> <u>75</u> |   |                 |                                   |                 |     |
|---|---|-----------------|-----------------------------------|-----------------|-----|
| Standard Modules  | Basic Part Number<br>Standard Materials # |                 | Face Width                        | Number of Teeth |     |
|   | Stainless Steel                           | Aluminium Alloy | Dim F                             | Min             | Max |
| 1.5   | C150S1B12                                 | C150A1B12       | F6A- (6mm)<br>or<br>F10A- (10 mm) | 18              | 72  |
| 1.25  | C125S1B12                                 | C125A1B12       |                                   | 20              | 86  |
| 1.0   | C10S1B12                                  | C10A1B12        |                                   | 22              | 109 |
| 0.8   | C08S1B12                                  | C08A1B12        |                                   | 25              | 136 |
| 0.6   | C06S1B12                                  | C06A1B12        |                                   | 30              | 183 |
| 0.5   | C05S1B12                                  | C05A1B12        |                                   | 34              | 220 |
| 0.4   | C04S1B12                                  | C04A1B12        |                                   | 40              | 275 |
| 0.3   | C03S1B12                                  | C03A1B12        |                                   | 50              | 368 |
| 0.25  | C025S1B12                                 | C025A1B12       |                                   | 58              | 442 |
| 0.2   | C02S1B12                                  | C02A1B12        |                                   | 70              | 553 |

# Alternative materials - replace **S1** in the part number with **B2** for brass

### **i** Features and options

- Gear quality AQ10 as standard - see page T4-1
- Gear quality AQ9 for 1.5 mod
- Higher gear qualities available - see page T4-1
- Imperial gears available
- For all gear types and options - see page 4-6
- Product overview - see pages 4-2 to 4-6

### **?** Technical support

- Material specifications - see page T4-4
- Lubrication - see page T4-10
- Installation information - see page T4-9
- Treatment specifications - see page T4-4
- Technical information - see pages T4-1 to T4-18
- For modified or fully bespoke gear solutions, please contact us





### Associated Products

Anti-backlash gears: page 4-13 to 4-35  
 Shafts: page 11-2  
 Bearings: page 12-1  
 Pins: page 13-18

All dimensions in mm  
 General tolerances  $\pm 0.13$  mm  
 Pressure angle 20°

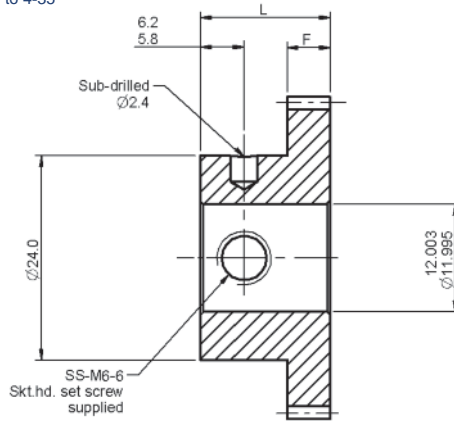

When F=8, L=20  
 F=12, L=24

## Part number selection table

| Example Part No:- <b>P06S1B12 F8A- 75</b> |   |                  |                                    |                 |            |
|---|---|------------------|------------------------------------|-----------------|------------|
| Standard Modules                          | Basic Part Number<br>Standard Materials # |                  | Face Width                         | Number of Teeth |            |
|   | Stainless Steel                           | Aluminium Alloy  | Dim F                              | Min             | Max        |
| 1.5                                       | <b>P150S1B12</b>                          | <b>P150A1B12</b> | F8A- (8 mm)<br>or<br>F12A- (12 mm) | <b>19</b>       | <b>72</b>  |
| 1.25                                      | <b>P125S1B12</b>                          | <b>P125A1B12</b> |                                    | <b>22</b>       | <b>86</b>  |
| 1.0                                       | <b>P10S1B12</b>                           | <b>P10A1B12</b>  |                                    | <b>26</b>       | <b>109</b> |
| 0.8                                       | <b>P08S1B12</b>                           | <b>P08A1B12</b>  |                                    | <b>32</b>       | <b>136</b> |
| 0.6                                       | <b>P06S1B12</b>                           | <b>P06A1B12</b>  |                                    | <b>41</b>       | <b>183</b> |
| 0.5                                       | <b>P05S1B12</b>                           | <b>P05A1B12</b>  |                                    | <b>48</b>       | <b>220</b> |
| 0.4                                       | <b>P04S1B12</b>                           | <b>P04A1B12</b>  |                                    | <b>59</b>       | <b>275</b> |
| 0.3                                       | <b>P03S1B12</b>                           | <b>P03A1B12</b>  |                                    | <b>77</b>       | <b>368</b> |
| 0.25                                      | <b>P025S1B12</b>                          | <b>P025A1B12</b> |                                    | <b>92</b>       | <b>442</b> |
| 0.2                                       | <b>P02S1B12</b>                           | <b>P02A1B12</b>  |                                    | <b>113</b>      | <b>553</b> |

# Alternative materials - replace **S1** in the part number with **B2** for brass, or **S8** for hardened stainless steel

### **i** Features and options

- Gear quality AQ10 as standard - see page T4-1
- Gear quality AQ9 for 1.5 mod
- Higher gear qualities available - see page T4-1
- Imperial gears available
- For all gear types and options - see page 4-6
- Product overview - see pages 4-2 to 4-6

### **?** Technical support

- Material specifications - see page T4-4
- Lubrication - see page T4-10
- Installation information - see page T4-9
- Treatment specifications - see page T4-4
- Technical information - see pages T4-1 to T4-18
- For modified or fully bespoke gear solutions, please contact us

Precision Gears



All dimensions in mm  
 General tolerances  $\pm 0.13$  mm  
 Pressure angle  $20^\circ$

**Associated Products**  
 Anti-backlash gears: page 4-7 to 4-35  
 Shafts: page 11-2

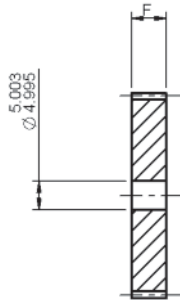

Note  
 Delrin gear bore  
 $\varnothing 5.02/4.97$

## Part number selection table

| Example Part No:- <b>F06S1B5 F3A- 75</b> |  |                 |             |                 |     |
|--|--|-----------------|-------------|-----------------|-----|
| Standard Modules                         | Basic Part Number Standard Materials # |                 | Face Width  | Number of Teeth |     |
|  | Stainless Steel                        | Aluminium Alloy | Dim F       | Min             | Max |
| 1.5                                      | <b>F150S1B5</b>                        | <b>F150A1B5</b> | F3A- (3 mm) | 14 †            | 72  |
| 1.25                                     | <b>F125S1B5</b>                        | <b>F125A1B5</b> |             | 14 †            | 86  |
| 1.0                                      | <b>F10S1B5</b>                         | <b>F10A1B5</b>  |             | 15 †            | 109 |
| 0.8                                      | <b>F08S1B5</b>                         | <b>F08A1B5</b>  |             | 17              | 136 |
| 0.6                                      | <b>F06S1B5</b>                         | <b>F06A1B5</b>  |             | 19              | 183 |
| 0.5                                      | <b>F05S1B5</b>                         | <b>F05A1B5</b>  | or          | 20              | 220 |
| 0.4                                      | <b>F04S1B5</b>                         | <b>F04A1B5</b>  | F6A- (6 mm) | 23              | 275 |
| 0.3                                      | <b>F03S1B5</b>                         | <b>F03A1B5</b>  |             | 27              | 368 |
| 0.25                                     | <b>F025S1B5</b>                        | <b>F025A1B5</b> |             | 30              | 442 |
| 0.2                                      | <b>F02S1B5</b>                         | <b>F02A1B5</b>  |             | 35              | 553 |

† Gears of 16 teeth or fewer will be modified - see page T4-8

# Alternative materials - replace **S1** in the part number with **B2** for brass, **D1** for Delrin or **S8** for hardened stainless steel

### **i** Features and options

- Gear quality AQ10 as standard - see page T4-1
- Gear quality AQ9 for 1.5 mod
- Higher gear qualities available - see page T4-1
- Imperial gears available
- For all gear types and options - see page 4-6
- Product overview - see pages 4-2 to 4-6

### **?** Technical support

- Material specifications - see page T4-4
- Lubrication - see page T4-10
- Installation information - see page T4-9
- Treatment specifications - see page T4-4
- Technical information - see pages T4-1 to T4-18
- For modified or fully bespoke gear solutions, please contact us



### Associated Products

Anti-backlash gears: page 4-7 to 4-35  
Shafts: page 11-2

All dimensions in mm  
General tolerances  $\pm 0.13$  mm  
Pressure angle  $20^\circ$

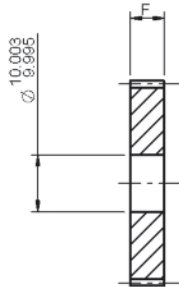

Note  
Delrin gear bore  
 $\varnothing 10.02/9.97$

## Part number selection table

| Example Part No:-  |   |                  |             |                 |            |
|--|---|------------------|-------------|-----------------|------------|
| <span style="margin-right: 20px;"><u>F06S1B10</u></span> <span style="margin-right: 20px;"><u>F6A-</u></span> <span><u>75</u></span> |   |                  |             |                 |            |
| Standard Modules   | Basic Part Number<br>Standard Materials # |                  | Face Width  | Number of Teeth |            |
|  | Stainless Steel                           | Aluminium Alloy  | Dim F       | Min             | Max        |
| 1.5  | <b>F150S1B10</b>                          | <b>F150A1B10</b> | F3A- (3 mm) | <b>17</b>       | <b>72</b>  |
| 1.25   | <b>F125S1B10</b>                          | <b>F125A1B10</b> |             | <b>18</b>       | <b>86</b>  |
| 1.0  | <b>F10S1B10</b>                           | <b>F10A1B10</b>  |             | <b>20</b>       | <b>109</b> |
| 0.8  | <b>F08S1B10</b>                           | <b>F08A1B10</b>  |             | <b>23</b>       | <b>136</b> |
| 0.6  | <b>F06S1B10</b>                           | <b>F06A1B10</b>  | or          | <b>27</b>       | <b>183</b> |
| 0.5  | <b>F05S1B10</b>                           | <b>F05A1B10</b>  | F6A- (6 mm) | <b>30</b>       | <b>220</b> |
| 0.4  | <b>F04S1B10</b>                           | <b>F04A1B10</b>  |             | <b>35</b>       | <b>275</b> |
| 0.3  | <b>F03S1B10</b>                           | <b>F03A1B10</b>  |             | <b>44</b>       | <b>368</b> |
| 0.25   | <b>F025S1B10</b>                          | <b>F025A1B10</b> |             | <b>50</b>       | <b>442</b> |
| 0.2  | <b>F02S1B10</b>                           | <b>F02A1B10</b>  |             | <b>60</b>       | <b>553</b> |

# Alternative materials - replace **S1** in the part number with **B2** for brass, **D1** for Delrin or **S8** for hardened stainless steel

### **i** Features and options

- Gear quality AQ10 as standard - see page T4-1
- Gear quality AQ9 for 1.5 mod
- Higher gear qualities available - see page T4-1
- Imperial gears available
- For all gear types and options - see page 4-6
- Product overview - see pages 4-2 to 4-6

### **?** Technical support

- Material specifications - see page T4-4
- Lubrication - see page T4-10
- Installation information - see page T4-9
- Treatment specifications - see page T4-4
- Technical information - see pages T4-1 to T4-18
- For modified or fully bespoke gear solutions, please contact us

Precision Gears



All dimensions in mm  
 General tolerances  $\pm 0.13$  mm  
 Pressure angle  $20^\circ$

**Associated Products**  
 Anti-backlash gears: page 4-7 to 4-35

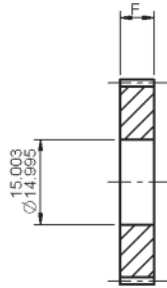

Note  
 Delrin gear bore  
 $\text{Ø}15.02/14.97$

## Part number selection table

| Example Part No:- |   | <b>F06S1B15</b>  | <b>F3A-</b>                              | <b>75</b>       |            |  |
|-------------------|---|------------------|--|-----------------|------------|--|
| Standard Modules  | Basic Part Number<br>Standard Materials # |                  | Face Width                               | Number of Teeth |            |  |
|                   | Stainless Steel                           | Aluminium Alloy  | Dim F                                    | Min             | Max        |  |
| 1.5               | <b>F150S1B15</b>                          | <b>F150A1B15</b> | F3A- (3 mm)<br><br>or<br><br>F6A- (6 mm) | <b>20</b>       | <b>72</b>  |  |
| 1.25              | <b>F125S1B15</b>                          | <b>F125A1B15</b> |  | <b>22</b>       | <b>86</b>  |  |
| 1.0               | <b>F10S1B15</b>                           | <b>F10A1B15</b>  |  | <b>25</b>       | <b>109</b> |  |
| 0.8               | <b>F08S1B15</b>                           | <b>F08A1B15</b>  |  | <b>29</b>       | <b>136</b> |  |
| 0.6               | <b>F06S1B15</b>                           | <b>F06A1B15</b>  |  | <b>35</b>       | <b>183</b> |  |
| 0.5               | <b>F05S1B15</b>                           | <b>F05A1B15</b>  |  | <b>40</b>       | <b>220</b> |  |
| 0.4               | <b>F04S1B15</b>                           | <b>F04A1B15</b>  |  | <b>48</b>       | <b>275</b> |  |
| 0.3               | <b>F03S1B15</b>                           | <b>F03A1B15</b>  |  | <b>60</b>       | <b>368</b> |  |
| 0.25              | <b>F025S1B15</b>                          | <b>F025A1B15</b> |  | <b>70</b>       | <b>442</b> |  |
| 0.2               | <b>F02S1B15</b>                           | <b>F02A1B15</b>  |  | <b>85</b>       | <b>553</b> |  |

# Alternative materials - replace **S1** in the part number with **B2** for brass, **D1** for Delrin or **S8** for hardened stainless steel

### **i** Features and options

- Gear quality AQ10 as standard - see page T4-1
- Gear quality AQ9 for 1.5 mod
- Higher gear qualities available - see page T4-1
- Imperial gears available
- For all gear types and options - see page 4-6
- Product overview - see pages 4-2 to 4-6

### **?** Technical support

- Material specifications - see page T4-4
- Lubrication - see page T4-10
- Installation information - see page T4-9
- Treatment specifications - see page T4-4
- Technical information - see pages T4-1 to T4-18
- For modified or fully bespoke gear solutions, please contact us



### Associated Products

Anti-backlash gears: page 4-7 to 4-35

All dimensions in mm  
General tolerances  $\pm 0.13$  mm  
Pressure angle 20°

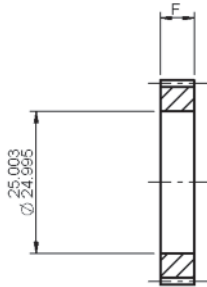

Note  
Delrin gear bore  
Ø25.02/24.97

## Part number selection table

| Example Part No:- |   | <u>F06S1B25</u> | <u>F6A-</u>       | <u>75</u>       |     |  |
|-------------------|---|-----------------|-------------------|-----------------|-----|--|
| Standard Modules  | Basic Part Number<br>Standard Materials # |                 | Face Width        | Number of Teeth |     |  |
|                   | Stainless Steel                           | Aluminium Alloy | Dim F             | Min             | Max |  |
| 1.5               | F150S1B25                                 | F150A1B25       | F3A- (3 mm)       | 27              | 72  |  |
| 1.25              | F125S1B25                                 | F125A1B25       |                   | 30              | 86  |  |
| 1.0               | F10S1B25                                  | F10A1B25        |                   | 35              | 109 |  |
| 0.8               | F08S1B25                                  | F08A1B25        | or<br>F6A- (6 mm) | 42              | 136 |  |
| 0.6               | F06S1B25                                  | F06A1B25        |                   | 52              | 183 |  |
| 0.5               | F05S1B25                                  | F05A1B25        |                   | 60              | 220 |  |
| 0.4               | F04S1B25                                  | F04A1B25        |                   | 73              | 275 |  |
| 0.3               | F03S1B25                                  | F03A1B25        |                   | 94              | 368 |  |
| 0.25              | F025S1B25                                 | F025A1B25       | 110               | 442             |     |  |
| 0.2               | F02S1B25                                  | F02A1B25        | 135               | 553             |     |  |

# Alternative materials - replace **S1** in the part number with **B2** for brass, **D1** for Delrin or **S8** for hardened stainless steel

### **i** Features and options

- Gear quality AQ10 as standard - see page T4-1
- Gear quality AQ9 for 1.5 mod
- Higher gear qualities available - see page T4-1
- Imperial gears available
- For all gear types and options - see page 4-6
- Product overview - see pages 4-2 to 4-6

### **?** Technical support

- Material specifications - see page T4-4
- Lubrication - see page T4-10
- Installation information - see page T4-9
- Treatment specifications - see page T4-4
- Technical information - see pages T4-1 to T4-18
- For modified or fully bespoke gear solutions, please contact us

Precision Gears



All dimensions in mm  
 General tolerances  $\pm 0.13$  mm  
 Material: Stainless steel 17-4 PH,  
 hardened to 35-42 HRC  
 Pressure angle  $20^\circ$

When  $F=2, L=8$   
 $F=4, L=10$

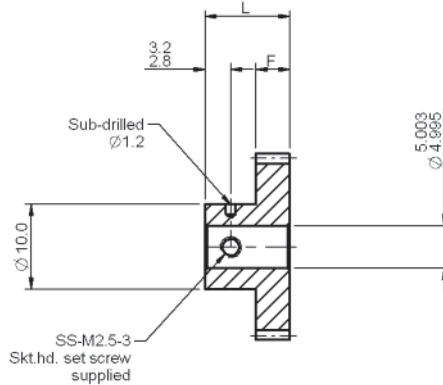

**Associated Products**  
 Pin hub spur gears: page 4-37 to 4-51  
 Shafts: page 11-2  
 Bearings: page 12-1  
 Pins: page 13-18

## Part number selection table

| Example Part No:- <b>P06S8B5 F2A- 25</b> |   |                     |                 |     |     |
|--|---|---------------------|-----------------|-----|-----|
| Standard Modules                         | Basic Part Number<br>Hardened Stainless Steel | Face Width<br>Dim F | Number of Teeth |     |     |
|  |   |                     | Min             | Max |     |
|  |   |                     |                 | F2A | F4A |
| 1.5                                      | P150S8B5                                      | F2A- (2 mm)         | 14 †            | 21  | 72  |
| 1.25                                     | P125S8B5                                      |                     | 14 †            | 25  | 86  |
| 1.0                                      | P10S8B5                                       |                     | 15 †            | 32  | 109 |
| 0.8                                      | P08S8B5                                       |                     | 17              | 41  | 136 |
| 0.6                                      | P06S8B5                                       | or                  | 21              | 56  | 183 |
| 0.5                                      | P05S8B5                                       | F4A- (4 mm)         | 24              | 67  | 220 |
| 0.4                                      | P04S8B5                                       |                     | 29              | 85  | 275 |
| 0.3                                      | P03S8B5                                       |                     | 37              | 114 | 368 |
| 0.25                                     | P025S8B5                                      |                     | 43              | 137 | 442 |
| 0.2                                      | P02S8B5                                       |                     | 53              | 172 | 553 |

† Gears of 16 teeth or fewer will be modified - see page T4-8

### **i** Features and options

- Gear quality AQ10 as standard - see page T4-1
- Gear quality AQ9 for 1.5 mod
- Higher gear qualities available - see page T4-1
- Additional bore sizes 2 mm to 12 mm available
- Imperial gears available
- For all gear types and options - see page 4-6
- Product overview - see pages 4-2 to 4-6

### **?** Technical support

- Material specifications - see page T4-4
- Lubrication - see page T4-10
- Installation information - see page T4-9
- Treatment specifications - see page T4-4
- Technical information - see pages T4-1 to T4-18
- For modified or fully bespoke gear solutions, please contact us



### Associated Products

Pin hub spur gears: page 4-37 to 4-51  
 Shafts: page 11-2  
 Bearings: page 12-1  
 Pins: page 13-18

All dimensions in mm  
 General tolerances  $\pm 0.13$  mm  
 Material: Stainless steel 17-4 PH,  
 hardened to 35-42 HRC  
 Pressure angle 20°

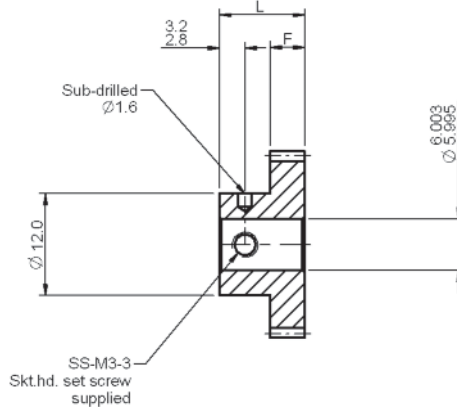

When F=3, L=9  
 F=4, L=10  
 F=6, L=12

### Part number selection table

| Example Part No:- |                          | <u>P06S8B6</u> | <u>F4A-</u>     | <u>25</u> |
|-------------------|--------------------------|----------------|-----------------|-----------|
| Standard Modules  | Basic Part Number        | Face Width     | Number of Teeth |           |
|                   | Hardened Stainless Steel | Dim F          | Min             | Max       |
| 1.5               | P150S8B6                 | F3A- (3 mm)    | 14 †            | 72        |
| 1.25              | P125S8B6                 |                | 15 †            | 86        |
| 1.0               | P10S8B6                  | or             | 16 †            | 109       |
| 0.8               | P08S8B6                  |                | 19              | 136       |
| 0.6               | P06S8B6                  | F4A- (4 mm)    | 23              | 183       |
| 0.5               | P05S8B6                  |                | 27              | 220       |
| 0.4               | P04S8B6                  |                | 33              | 275       |
| 0.3               | P03S8B6                  | or             | 43              | 368       |
| 0.25              | P025S8B6                 | F6A- (6 mm)    | 50              | 442       |
| 0.2               | P02S8B6                  |                | 62              | 553       |

† Gears of 16 teeth or fewer will be modified - see page T4-8

### **i** Features and options

- Gear quality AQ10 as standard - see page T4-1
- Gear quality AQ9 for 1.5 mod
- Higher gear qualities available - see page T4-1
- Additional bore sizes 2 mm to 12 mm available
- Imperial gears available
- For all gear types and options - see page 4-6
- Product overview - see pages 4-2 to 4-6

### **?** Technical support

- Material specifications - see page T4-4
- Lubrication - see page T4-10
- Installation information - see page T4-9
- Treatment specifications - see page T4-4
- Technical information - see pages T4-1 to T4-18
- For modified or fully bespoke gear solutions, please contact us

Precision Gears



All dimensions in mm  
 General tolerances  $\pm 0.13$  mm  
 Material: Stainless steel 17-4 PH,  
 hardened to 35-42 HRC  
 Pressure angle  $20^\circ$

### Associated Products

Pin hub spur gears: page 4-37 to 4-51  
 Shafts: page 11-2  
 Bearings: page 12-1  
 Pins: page 13-18

When  $F=4, L=10$   
 $F=6, L=12$

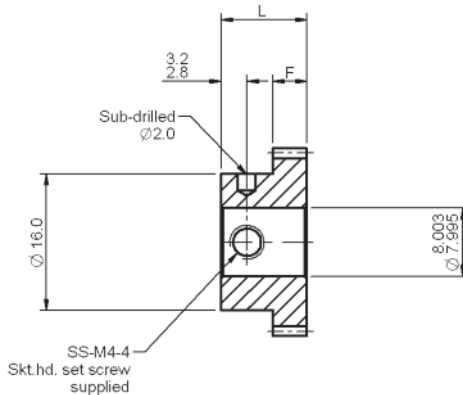

## Part number selection table

| Example Part No:- <b>P06S8B8 F4A- 50</b> |                          |                                  |                 |     |
|--|--------------------------|----------------------------------|-----------------|-----|
| Standard Modules                         | Basic Part Number        | Face Width                       | Number of Teeth |     |
|  | Hardened Stainless Steel | Dim F                            | Min             | Max |
| 1.5                                      | P150S8B8                 | F4A- (4 mm)<br>or<br>F6A- (6 mm) | 16 †            | 72  |
| 1.25                                     | P125S8B8                 |                                  | 17              | 86  |
| 1.0                                      | P10S8B8                  |                                  | 20              | 109 |
| 0.8                                      | P08S8B8                  |                                  | 24              | 136 |
| 0.6                                      | P06S8B8                  |                                  | 30              | 183 |
| 0.5                                      | P05S8B8                  |                                  | 35              | 220 |
| 0.4                                      | P04S8B8                  | 43                               | 275             |     |
| 0.3                                      | P03S8B8                  | 56                               | 368             |     |
| 0.25                                     | P025S8B8                 | 66                               | 442             |     |
| 0.2                                      | P02S8B8                  | 82                               | 553             |     |

† Gears of 16 teeth or fewer will be modified - see page T4-8

### **i** Features and options

- Gear quality AQ10 as standard - see page T4-1
- Gear quality AQ9 for 1.5 mod
- Higher gear qualities available - see page T4-1
- Additional bore sizes 2 mm to 12 mm available
- Imperial gears available
- For all gear types and options - see page 4-6
- Product overview - see pages 4-2 to 4-6

### **?** Technical support

- Material specifications - see page T4-4
- Lubrication - see page T4-10
- Installation information - see page T4-9
- Treatment specifications - see page T4-4
- Technical information - see pages T4-1 to T4-18
- For modified or fully bespoke gear solutions, please contact us





### Associated Products

Pin hub spur gears: page 4-37 to 4-51  
 Shafts: page 11-2  
 Bearings: page 12-1  
 Pins: page 13-18

All dimensions in mm  
 General tolerances  $\pm 0.13$  mm  
 Material: Stainless steel 17-4 PH,  
 hardened to 35-42 HRC  
 Pressure angle 20°

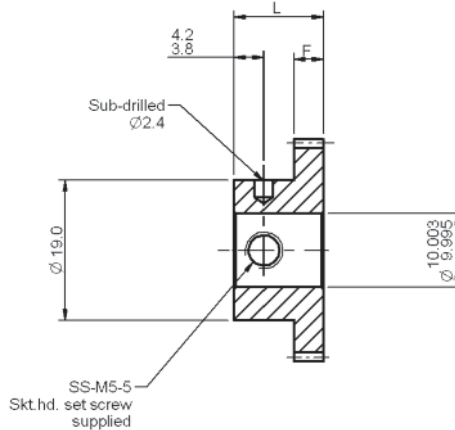

When F=4, L=12  
 F=6, L=14

## Part number selection table

| Example Part No:- |                          | <u>P06S8B10</u>                          | <u>F4A-</u>     | <u>65</u> |
|-------------------|--------------------------|--|-----------------|-----------|
| Standard Modules  | Basic Part Number        | Face Width                               | Number of Teeth |           |
|                   | Hardened Stainless Steel | Dim F                                    | Min             | Max       |
| 1.5               | P150S8B10                | F4A- (4 mm)<br><br>or<br><br>F6A- (6 mm) | 17              | 72        |
| 1.25              | P125S8B10                |  | 19              | 86        |
| 1.0               | P10S8B10                 |  | 22              | 109       |
| 0.8               | P08S8B10                 |  | 27              | 136       |
| 0.6               | P06S8B10                 |  | 34              | 183       |
| 0.5               | P05S8B10                 |  | 40              | 220       |
| 0.4               | P04S8B10                 |  | 50              | 275       |
| 0.3               | P03S8B10                 |  | 65              | 368       |
| 0.25              | P025S8B10                |  | 77              | 442       |
| 0.2               | P02S8B10                 |  | 95              | 553       |

### **i** Features and options

- Gear quality AQ10 as standard - see page T4-1
- Gear quality AQ9 for 1.5 mod
- Higher gear qualities available - see page T4-1
- Additional bore sizes 2 mm to 12 mm available
- Imperial gears available
- For all gear types and options - see page 4-6
- Product overview - see pages 4-2 to 4-6

### **?** Technical support

- Material specifications - see page T4-4
- Lubrication - see page T4-10
- Installation information - see page T4-9
- Treatment specifications - see page T4-4
- Technical information - see pages T4-1 to T4-18
- For modified or fully bespoke gear solutions, please contact us

Precision Gears



## Ground spur gears

Ground spur gears are ideal for high speed mechatronic applications where higher loads and accurate motion are required.

- Modules 0.5 to 1.0 available.
- Manufactured from chromium molybdenum steel, hardened to 49-55HRc.
- Standard gear quality: ISO 5
- Bore diameter, outside diameter and other surfaces are ground to provide location datums when additional machining is required. Additional machining of the bore is not recommended.
- Keyway features available - see [page 4-69](#)



## Part number structure

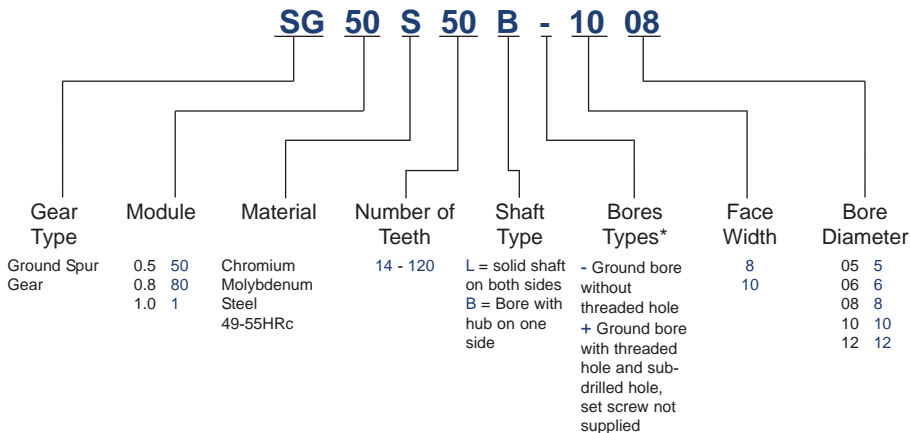

\* See bore type designator in part number, - or +



Associated Products  
Bearings: page 12-1

All dimensions in mm  
Pressure angle 20°

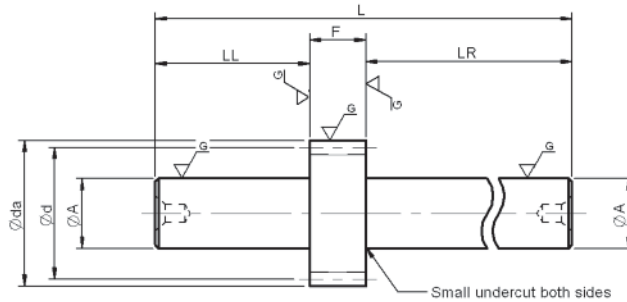

### Part number selection table

| Part Number   | Module | Number of Teeth | PCD  |      | Face Width F | Shaft Dia (h7) ØA | Shaft Length |    | Overall Length L |
|---------------|--------|-----------------|------|------|--------------|-------------------|--------------|----|------------------|
|               |        |                 | Ød   | Øda  |              |                   | LL           | LR |                  |
| SG50S20L-0806 | 0.5    | 20              | 10.0 | 11.0 | 8            | 6                 | 22           | 50 | 80               |
| SG50S22L-0808 |        | 22              | 11.0 | 12.0 |              | 8                 |              |    |                  |
| SG50S24L-0810 |        | 24              | 12.0 | 13.0 |              | 10                |              |    |                  |
| SG50S25L-0810 |        | 25              | 12.5 | 13.5 |              | 10                |              |    |                  |
| SG50S26L-0810 |        | 26              | 13.0 | 14.0 |              | 10                |              |    |                  |
| SG80S15L-0806 | 0.8    | 15              | 12.0 | 13.6 | 8            | 6                 | 22           | 60 | 90               |
| SG80S16L-0806 |        | 16              | 12.8 | 14.4 |              | 6                 |              |    |                  |
| SG80S18L-0808 |        | 18              | 14.4 | 16.0 |              | 8                 |              |    |                  |
| SG80S20L-0810 |        | 20              | 16.0 | 17.6 |              | 10                |              |    |                  |
| SG80S24L-0810 |        | 24              | 19.2 | 20.8 |              | 10                |              |    |                  |
| SG80S25L-0810 |        | 25              | 20.0 | 21.6 |              | 10                |              |    |                  |
| SG1S14L-1008  | 1.0    | 14              | 14.0 | 16.0 | 10           | 8                 | 25           | 60 | 95               |
| SG1S15L-1010  |        | 15              | 15.0 | 17.0 |              | 10                |              |    |                  |
| SG1S16L-1010  |        | 16              | 16.0 | 18.0 |              | 10                |              |    |                  |
| SG1S18L-1010  |        | 18              | 18.0 | 20.0 |              | 10                |              |    |                  |

### Features

- Material: Chromium molybdenum steel (ISO 34CrMo4, 42CrMo4)
- Gear tooth treatment: Induction hardened to 49-55 HRc
- Gear quality: ISO 5
- Gear tooth surface finish  $\sqrt{1.6}$

### Technical support

- For transmission capacity - see page T4-17
- Part number structure - see page 4-60
- Small quantities of selected items available ex-stock, please visit our on-line store: [www.reliance.co.uk/shop](http://www.reliance.co.uk/shop)
- For modified or fully bespoke gears, please contact us



All dimensions in mm  
Pressure angle 20°

**Associated Products**  
Set screws: page 13-1  
Shafts: page 11-2  
Bearings: page 12-1

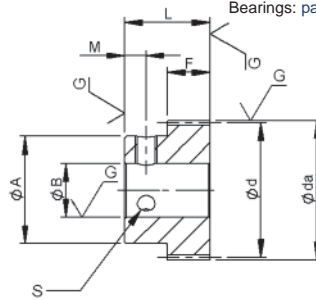
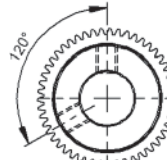
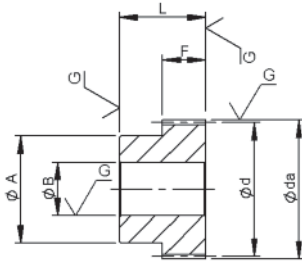

- in part number denotes no threaded hole

\* in part number denotes two threaded holes (set screws not supplied)

## Part number selection table

| Part Number   | Number of Teeth | PCD<br>$\phi d$ | OD<br>$\phi da$ | Bore Dia (H7)<br>$\phi B$ | Hub Dia<br>$\phi A$ | Face Width<br>F | Overall Length<br>L | Set Screw |   |
|---------------|-----------------|-----------------|-----------------|---------------------------|---------------------|-----------------|---------------------|-----------|---|
|               |                 |                 |                 |                           |                     |                 |                     | S         | M |
| SG50S28B-0805 | 28              | 14.0            | 15.0            | 5                         | 10                  | 8               | 16                  | -         | - |
| SG50S30B-0805 | 30              | 15.0            | 16.0            | 5                         | 12                  |                 |                     | -         | - |
| SG50S30B-0806 | 30              | 15.0            | 16.0            | 6                         | 12                  |                 |                     | -         | - |
| SG50S30B*0806 | 30              | 15.0            | 16.0            | 6                         | 12                  |                 |                     | M3        | 4 |
| SG50S32B-0805 | 32              | 16.0            | 17.0            | 5                         | 12                  |                 |                     | -         | - |
| SG50S32B-0806 | 32              | 16.0            | 17.0            | 6                         | 12                  |                 |                     | -         | - |
| SG50S35B-0805 | 35              | 17.5            | 18.5            | 5                         | 14                  |                 |                     | -         | - |
| SG50S36B-0806 | 36              | 18.0            | 19.0            | 6                         | 16                  |                 |                     | -         | - |
| SG50S36B-0808 | 36              | 18.0            | 19.0            | 8                         | 16                  |                 |                     | -         | - |
| SG50S40B-0806 | 40              | 20.0            | 21.0            | 6                         | 16                  |                 |                     | -         | - |
| SG50S40B-0808 | 40              | 20.0            | 21.0            | 8                         | 16                  |                 |                     | -         | - |
| SG50S40B*0808 | 40              | 20.0            | 21.0            | 8                         | 16                  |                 |                     | M4        | 4 |
| SG50S45B-0808 | 45              | 22.5            | 23.5            | 8                         | 16                  |                 |                     | -         | - |
| SG50S48B-0808 | 48              | 24.0            | 25.0            | 8                         | 20                  |                 |                     | -         | - |
| SG50S50B-0808 | 50              | 25.0            | 26.0            | 8                         | 20                  |                 |                     | -         | - |
| SG50S50B-0810 | 50              | 25.0            | 26.0            | 10                        | 20                  |                 |                     | -         | - |
| SG50S50B*0810 | 50              | 25.0            | 26.0            | 10                        | 20                  | M4              | 4                   |           |   |
| SG50S54B-0808 | 54              | 27.0            | 28.0            | 8                         | 20                  | -               | -                   |           |   |
| SG50S55B-0808 | 55              | 27.5            | 28.5            | 8                         | 20                  | -               | -                   |           |   |

Precision Gears

### Features

- Material: Chromium molybdenum steel (ISO 34CrMo4, 42CrMo4)
- Gear tooth treatment: Induction hardened to 49-55 HRc
- Gear quality: ISO 5
- Gear tooth surface finish  $\sqrt{R_a}$
- Keyway features available - see page 4-69

### Technical support

- For transmission capacity - see page T4-17
- Part number structure - see page 4-60
- Small quantities of selected items available ex-stock, please visit our on-line store: [www.reliance.co.uk/shop](http://www.reliance.co.uk/shop)
- For modified or fully bespoke gears, please contact us



**Associated Products**  
 Set screws: page 13-1  
 Shafts: page 11-2  
 Bearings: page 12-1

All dimensions in mm  
 Pressure angle 20

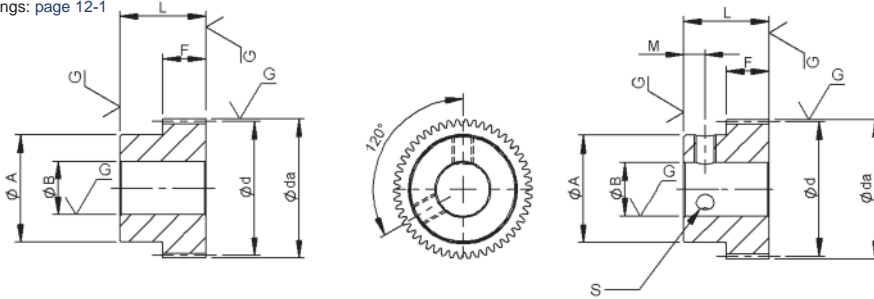

- in part number denotes no threaded hole

\* in part number denotes two threaded holes (set screws not supplied)

### Part number selection table

| Part Number    | Number of Teeth | PCD<br>Ød | OD<br>Øda | Bore Dia (H7)<br>ØB | Hub Dia<br>ØA | Face Width<br>F | Overall Length<br>L | Set Screw |   |
|----------------|-----------------|-----------|-----------|---------------------|---------------|-----------------|---------------------|-----------|---|
|                |                 |           |           |                     |               |                 |                     | S         | M |
| SG50S56B-0808  | 56              | 28.0      | 29.0      | 8                   | 20            |                 |                     | -         | - |
| SG50S60B-0808  | 60              | 30.0      | 31.0      | 8                   | 22            |                 |                     | -         | - |
| SG50S60B-0810  | 60              | 30.0      | 31.0      | 10                  | 22            |                 |                     | -         | - |
| SG50S60B*0810  | 60              | 30.0      | 31.0      | 10                  | 22            |                 |                     | M4        | 4 |
| SG50S64B-0808  | 64              | 32.0      | 33.0      | 8                   | 22            |                 |                     | -         | - |
| SG50S70B-0808  | 70              | 35.0      | 36.0      | 8                   | 22            |                 |                     | -         | - |
| SG50S72B-0808  | 72              | 36.0      | 37.0      | 8                   | 25            |                 |                     | -         | - |
| SG50S75B-0808  | 75              | 37.5      | 38.5      | 8                   | 25            |                 |                     | -         | - |
| SG50S80B-0808  | 80              | 40.0      | 41.0      | 8                   | 25            |                 |                     | -         | - |
| SG50S80B-0810  | 80              | 40.0      | 41.0      | 10                  | 25            |                 |                     | -         | - |
| SG50S80B-0812  | 80              | 40.0      | 41.0      | 12                  | 25            | 8               | 16                  | -         | - |
| SG50S80B*0812  | 80              | 40.0      | 41.0      | 12                  | 25            |                 |                     | M5        | 4 |
| SG50S90B-0810  | 90              | 45.0      | 46.0      | 10                  | 30            |                 |                     | -         | - |
| SG50S96B-0810  | 96              | 48.0      | 49.0      | 10                  | 30            |                 |                     | -         | - |
| SG50S100B-0810 | 100             | 50.0      | 51.0      | 10                  | 30            |                 |                     | -         | - |
| SG50S100B-0812 | 100             | 50.0      | 51.0      | 12                  | 30            |                 |                     | -         | - |
| SG50S100B*0812 | 100             | 50.0      | 51.0      | 12                  | 30            |                 |                     | M5        | 4 |
| SG50S108B-0810 | 108             | 54.0      | 55.0      | 10                  | 35            |                 |                     | -         | - |
| SG50S112B-0810 | 112             | 56.0      | 57.0      | 10                  | 35            |                 |                     | -         | - |
| SG50S120B-0810 | 120             | 60.0      | 61.0      | 10                  | 35            |                 |                     | -         | - |

### **i** Features

- Material: Chromium molybdenum steel (ISO 34CrMo4, 42CrMo4)
- Gear tooth treatment: Induction hardened to 49-55 HRc
- Gear quality: ISO 5
- Gear tooth surface finish  $\sqrt{1.6}$
- Keyway features available - see page 4-69

### **?** Technical support

- For transmission capacity - see page T4-17
- Part number structure - see page 4-60
- Small quantities of selected items available ex-stock, please visit our on-line store: [www.reliance.co.uk/shop](http://www.reliance.co.uk/shop)
- For modified or fully bespoke gears, please contact us



All dimensions in mm  
Pressure angle 20°

## Associated Products

Set screws: page 13-1

Shafts: page 11-2

Bearings: page 12-1

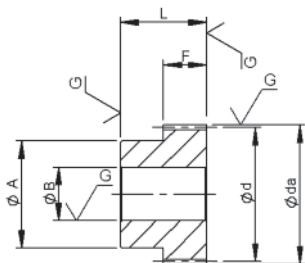

- in part number denotes no threaded hole

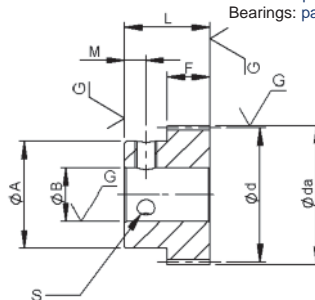
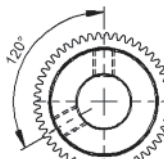

\* in part number denotes two threaded holes (set screws not supplied)

## Part number selection table

| Part Number   | Number of Teeth | PCD<br>Ød | OD<br>Øda | Bore Dia (H7)<br>ØB | Hub Dia<br>ØA | Face Width<br>F | Overall Length<br>L | Set Screw |   |
|---------------|-----------------|-----------|-----------|---------------------|---------------|-----------------|---------------------|-----------|---|
|               |                 |           |           |                     |               |                 |                     | S         | M |
| SG80S22B-0806 | 22              | 17.6      | 19.2      | 6                   | 14            | 8               | 18                  | -         | - |
| SG80S24B-0806 | 24              | 19.2      | 20.8      | 6                   | 16            |                 |                     | -         | - |
| SG80S25B-0806 | 25              | 20.0      | 21.6      | 6                   | 16            |                 |                     | -         | - |
| SG80S28B-0808 | 28              | 22.4      | 24.0      | 8                   | 18            |                 |                     | -         | - |
| SG80S30B-0810 | 30              | 24.0      | 25.6      | 10                  | 20            |                 |                     | -         | - |
| SG80S30B*0810 | 30              | 24.0      | 25.6      | 10                  | 20            |                 |                     | M4        | 5 |
| SG80S32B-0810 | 32              | 25.6      | 27.2      | 10                  | 20            |                 |                     | -         | - |
| SG80S35B-0810 | 35              | 28.0      | 29.6      | 10                  | 20            |                 |                     | -         | - |
| SG80S36B-0810 | 36              | 28.8      | 30.4      | 10                  | 20            |                 |                     | -         | - |
| SG80S40B-0810 | 40              | 32.0      | 33.6      | 10                  | 25            |                 |                     | -         | - |
| SG80S40B*0812 | 40              | 32.0      | 33.6      | 12                  | 25            |                 |                     | M5        | 5 |
| SG80S45B-0810 | 45              | 36.0      | 37.6      | 10                  | 25            |                 |                     | -         | - |
| SG80S48B-0810 | 48              | 38.4      | 40.0      | 10                  | 25            |                 |                     | -         | - |
| SG80S50B-0810 | 50              | 40.0      | 41.6      | 10                  | 25            |                 |                     | -         | - |
| SG80S50B*0812 | 50              | 40.0      | 41.6      | 12                  | 25            |                 |                     | M5        | 5 |
| SG80S54B-0810 | 54              | 43.2      | 44.8      | 10                  | 25            |                 |                     | -         | - |
| SG80S55B-0810 | 55              | 44.0      | 45.6      | 10                  | 25            | -               | -                   |           |   |

### **i** Features

- Material: Chromium molybdenum steel (ISO 34CrMo4, 42CrMo4)
- Gear tooth treatment: Induction hardened to 49-55 HRc
- Gear quality: ISO 5
- Gear tooth surface finish  $\sqrt{1.6}$
- Keyway features available - see page 4-69

### **?** Technical support

- For transmission capacity - see page T4-17
- Part number structure - see page 4-60
- Small quantities of selected items available ex-stock, please visit our on-line store: [www.reliance.co.uk/shop](http://www.reliance.co.uk/shop)
- For modified or fully bespoke gears, please contact us



**Associated Products**  
 Set screws: page 13-1  
 Shafts: page 11-2  
 Bearings: page 12-1

All dimensions in mm  
 Pressure angle 20°

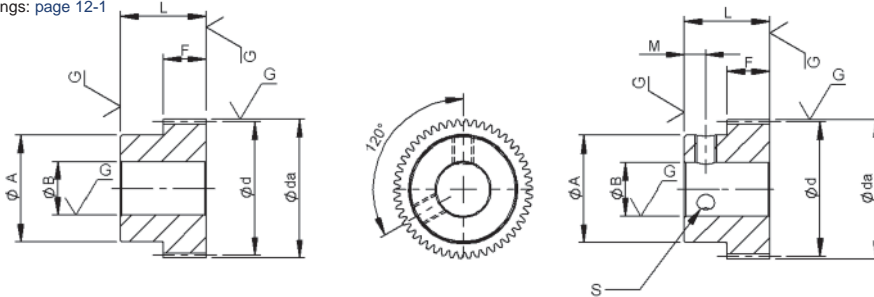

- in part number denotes no threaded hole

\* in part number denotes two threaded holes (set screws not supplied)

### Part number selection table

| Part Number    | Number of Teeth | PCD<br>Ød | OD<br>Øda | Bore Dia (H7)<br>ØB | Hub Dia<br>ØA | Face Width<br>F | Overall Length<br>L | Set Screw |   |
|----------------|-----------------|-----------|-----------|---------------------|---------------|-----------------|---------------------|-----------|---|
|                |                 |           |           |                     |               |                 |                     | S         | M |
| SG80S56B-0810  | 56              | 44.8      | 46.4      | 10                  | 25            |                 |                     | -         | - |
| SG80S60B-0810  | 60              | 48.0      | 49.6      | 10                  | 25            |                 |                     | -         | - |
| SG80S60B*0812  | 60              | 48.0      | 49.6      | 12                  | 25            |                 |                     | M5        | 5 |
| SG80S64B-0812  | 64              | 51.2      | 52.8      | 12                  | 30            |                 |                     | -         | - |
| SG80S70B-0812  | 70              | 56.0      | 57.6      | 12                  | 30            |                 |                     | -         | - |
| SG80S72B-0812  | 72              | 57.6      | 59.2      | 12                  | 30            |                 |                     | -         | - |
| SG80S75B-0812  | 75              | 60.0      | 61.6      | 12                  | 30            |                 |                     | -         | - |
| SG80S80B-0812  | 80              | 64.0      | 65.6      | 12                  | 30            | 8               | 18                  | -         | - |
| SG80S90B-0812  | 90              | 72.0      | 73.6      | 12                  | 35            |                 |                     | -         | - |
| SG80S96B-0812  | 96              | 76.8      | 78.4      | 12                  | 35            |                 |                     | -         | - |
| SG80S100B-0812 | 100             | 80.0      | 81.6      | 12                  | 35            |                 |                     | -         | - |
| SG80S108B-0812 | 108             | 86.4      | 88.0      | 12                  | 40            |                 |                     | -         | - |
| SG80S112B-0812 | 112             | 89.6      | 91.2      | 12                  | 40            |                 |                     | -         | - |
| SG80S120B-0812 | 120             | 96.0      | 97.6      | 12                  | 40            |                 |                     | -         | - |

### **i** Features

- Material: Chromium molybdenum steel (ISO 34CrMo4, 42CrMo4)
- Gear tooth treatment: Induction hardened to 49-55 HRc
- Gear quality: ISO 5
- Gear tooth surface finish  $\sqrt{1.6}$
- Keyway features available - see page 4-69

### **?** Technical support

- For transmission capacity - see page T4-17
- Part number structure - see page 4-60
- Small quantities of selected items available ex-stock, please visit our on-line store: [www.reliance.co.uk/shop](http://www.reliance.co.uk/shop)
- For modified or fully bespoke gears, please contact us

Precision Gears



All dimensions in mm  
Pressure angle 20°

**Associated Products**  
Set screws: page 13-1  
Shafts: page 11-2  
Bearings: page 12-1

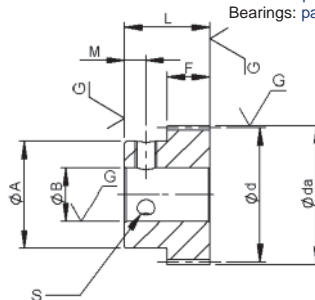
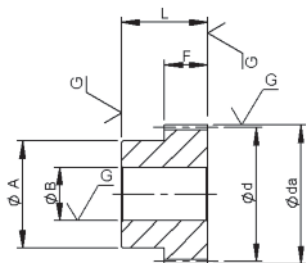

- in part number denotes no threaded hole

\* in part number denotes two threaded holes (set screws not supplied)

## Part number selection table

| Part Number  | Number of Teeth | PCD<br>Ød | OD<br>Øda | Bore Dia (H7)<br>ØB | Hub Dia<br>ØA | Face Width<br>F | Overall Length<br>L | Set Screw |   |
|--------------|-----------------|-----------|-----------|---------------------|---------------|-----------------|---------------------|-----------|---|
|              |                 |           |           |                     |               |                 |                     | S         | M |
| SG1S17B-1006 | 17              | 17.0      | 19.0      | 6                   | 12            |                 |                     | -         | - |
| SG1S18B-1008 | 18              | 18.0      | 20.0      | 8                   | 15            |                 |                     | -         | - |
| SG1S20B-1008 | 20              | 20.0      | 22.0      | 8                   | 16            |                 |                     | -         | - |
| SG1S20B*1008 | 20              | 20.0      | 22.0      | 8                   | 16            |                 |                     | M4        | 5 |
| SG1S20B*1010 | 20              | 20.0      | 22.0      | 10                  | 16            |                 |                     | M4        | 5 |
| SG1S21B-1008 | 21              | 21.0      | 23.0      | 8                   | 16            |                 |                     | -         | - |
| SG1S22B-1008 | 22              | 22.0      | 24.0      | 8                   | 18            |                 |                     | -         | - |
| SG1S23B-1008 | 23              | 23.0      | 25.0      | 8                   | 18            |                 |                     | -         | - |
| SG1S24B-1008 | 24              | 24.0      | 26.0      | 8                   | 20            | 10              | 20                  | -         | - |
| SG1S24B*1008 | 24              | 24.0      | 26.0      | 8                   | 20            |                 |                     | M4        | 5 |
| SG1S24B*1010 | 24              | 24.0      | 26.0      | 10                  | 20            |                 |                     | M4        | 5 |
| SG1S25B-1008 | 25              | 25.0      | 27.0      | 8                   | 20            |                 |                     | -         | - |
| SG1S26B-1008 | 26              | 26.0      | 28.0      | 8                   | 20            |                 |                     | -         | - |
| SG1S27B-1008 | 27              | 27.0      | 29.0      | 8                   | 20            |                 |                     | -         | - |
| SG1S28B-1008 | 28              | 28.0      | 30.0      | 8                   | 20            |                 |                     | -         | - |
| SG1S30B-1010 | 30              | 30.0      | 32.0      | 10                  | 26            |                 |                     | -         | - |
| SG1S30B*1010 | 30              | 30.0      | 32.0      | 10                  | 26            |                 |                     | M4        | 5 |

### **i** Features

- Material: Chromium molybdenum steel (ISO 34CrMo4, 42CrMo4)
- Gear tooth treatment: Induction hardened to 49-55 HRc
- Gear quality: ISO 5
- Gear tooth surface finish  $\sqrt{1.6}$
- Keyway features available - see page 4-69

### **?** Technical support

- For transmission capacity - see page T4-17
- Part number structure - see page 4-60
- Small quantities of selected items available ex-stock, please visit our on-line store: [www.reliance.co.uk/shop](http://www.reliance.co.uk/shop)
- For modified or fully bespoke gears, please contact us





**Associated Products**  
 Set screws: page 13-1  
 Shafts: page 11-2  
 Bearings: page 12-1

All dimensions in mm  
 Pressure angle 20°

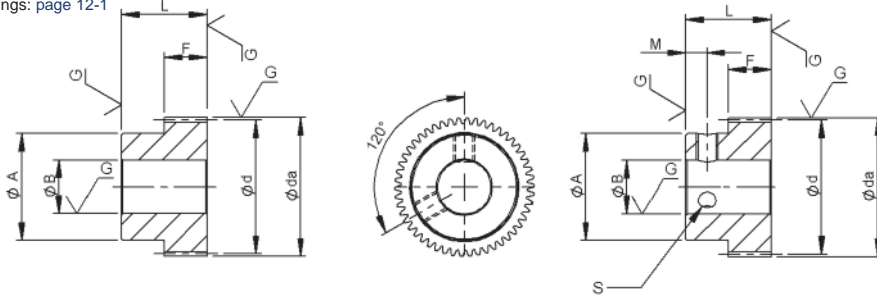

- in part number denotes no threaded hole

\* in part number denotes two threaded holes (set screws not supplied)

### Part number selection table

| Part Number         | Number of Teeth | PCD<br>Ød | OD<br>Øda | Bore Dia (H7)<br>ØB | Hub Dia<br>ØA | Face Width<br>F | Overall Length<br>L | Set Screw |   |
|---------------------|-----------------|-----------|-----------|---------------------|---------------|-----------------|---------------------|-----------|---|
|                     |                 |           |           |                     |               |                 |                     | S         | M |
| <b>SG1S30B*1012</b> | 30              | 30.0      | 32.0      | 12                  | 26            | 10              | 20                  | M4        | 5 |
| <b>SG1S32B-1010</b> | 32              | 32.0      | 34.0      | 10                  | 26            |                 |                     | -         | - |
| <b>SG1S34B-1010</b> | 34              | 34.0      | 36.0      | 10                  | 26            |                 |                     | -         | - |
| <b>SG1S35B-1010</b> | 35              | 35.0      | 37.0      | 10                  | 26            |                 |                     | -         | - |
| <b>SG1S36B-1010</b> | 36              | 36.0      | 38.0      | 10                  | 26            |                 |                     | -         | - |
| <b>SG1S38B-1010</b> | 38              | 38.0      | 40.0      | 10                  | 26            |                 |                     | -         | - |
| <b>SG1S40B-1010</b> | 40              | 40.0      | 42.0      | 10                  | 26            |                 |                     | -         | - |
| <b>SG1S40B-1012</b> | 40              | 40.0      | 42.0      | 12                  | 26            |                 |                     | -         | - |
| <b>SG1S42B-1010</b> | 42              | 42.0      | 44.0      | 10                  | 35            |                 |                     | -         | - |
| <b>SG1S44B-1010</b> | 44              | 44.0      | 46.0      | 10                  | 35            |                 |                     | -         | - |
| <b>SG1S45B-1012</b> | 45              | 45.0      | 47.0      | 12                  | 35            |                 |                     | -         | - |
| <b>SG1S48B-1012</b> | 48              | 48.0      | 50.0      | 12                  | 35            |                 |                     | -         | - |
| <b>SG1S50B-1012</b> | 50              | 50.0      | 52.0      | 12                  | 35            |                 |                     | -         | - |

### **i** Features

- Material: Chromium molybdenum steel (ISO 34CrMo4, 42CrMo4)
- Gear tooth treatment: Induction hardened to 49-55 HRc
- Gear quality: ISO 5
- Gear tooth surface finish  $\sqrt{1.6}$
- Keyway features available - see page 4-69

### **?** Technical support

- For transmission capacity - see page T4-17
- Part number structure - see page 4-60
- Small quantities of selected items available ex-stock, please visit our on-line store: [www.reliance.co.uk/shop](http://www.reliance.co.uk/shop)
- For modified or fully bespoke gears, please contact us

Precision Gears



All dimensions in mm  
Pressure angle 20°

**Associated Products**  
Set screws: page 13-1  
Shafts: page 11-2  
Bearings: page 12-1

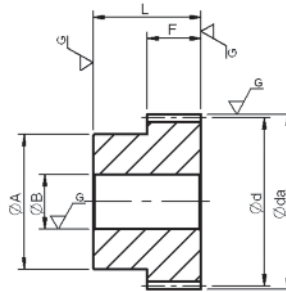

- in part number denotes no threaded hole

### Part number selection table

| Part Number   | Number of Teeth | PCD   | OD    | Bore Dia (H7) | Hub Dia | Face Width | Overall Length |
|---------------|-----------------|-------|-------|---------------|---------|------------|----------------|
|               |                 | Ød    | Øda   | ØB            | ØA      | F          | L              |
| SG1S52B-1012  | 52              | 52.0  | 54.0  | 12            | 35      | 10         | 20             |
| SG1S54B-1012  | 54              | 54.0  | 56.0  |               |         |            |                |
| SG1S55B-1012  | 55              | 55.0  | 57.0  |               |         |            |                |
| SG1S56B-1012  | 56              | 56.0  | 58.0  |               |         |            |                |
| SG1S60B-1012  | 60              | 60.0  | 62.0  |               |         |            |                |
| SG1S64B-1012  | 64              | 64.0  | 66.0  |               |         |            |                |
| SG1S70B-1012  | 70              | 70.0  | 72.0  |               |         |            |                |
| SG1S72B-1012  | 72              | 72.0  | 74.0  |               |         |            |                |
| SG1S75B-1012  | 75              | 75.0  | 77.0  |               |         |            |                |
| SG1S80B-1012  | 80              | 80.0  | 82.0  |               |         |            |                |
| SG1S100B-1012 | 100             | 100.0 | 102.0 | 50            |         |            |                |

Precision Gears

### **i** Features

- Material: Chromium molybdenum steel (ISO 34CrMo4, 42CrMo4)
- Gear tooth treatment: Induction hardened to 49-55 HRc
- Gear quality: ISO 5
- Gear tooth surface finish  $\sqrt{R}$
- Keyway features available - see page 4-69

### **?** Technical support

- For transmission capacity - see page T4-17
- Part number structure - see page 4-60
- Small quantities of selected items available ex-stock, please visit our on-line store: [www.reliance.co.uk/shop](http://www.reliance.co.uk/shop)
- For modified or fully bespoke gears, please contact us



### Associated Products

Ground pin hub spur gears: page 4-62

All dimensions in mm



### Tolerances for key

| b x t           | 3 x 3 | 4 x 4 |
|-----------------|-------|-------|
| b Tolerance (h) | h9    | h9    |
| t Tolerance (h) | h9    | h9    |

### Keyway information

| Bore Dia<br>Ø | Keyway<br>b <sub>2</sub> x t <sub>2</sub> | Width          |                | Depth          |            |
|---------------|---|----------------|----------------|----------------|------------|
|               |   | b <sub>2</sub> | Tolerance Js 9 | t <sub>2</sub> | Tolerance  |
| 8             | 3 x 1.4                                   | 3              | ±0.0125        | 1.4            | +0.1<br>-0 |
| 10            |   |                |                |                |            |
| 12            | 4 x 1.8                                   | 4              | ±0.015         | 1.8            |            |

### **i** Features

- The keyways above are available as options, add **-K** to the end of the part number
- Additional custom keyways are available, please contact us



## Brass gears

Brass gears are ideal for lightly loaded applications, an economic balance of accuracy and load capacity against cost.

- Modules 0.3 to 0.75 available
- Manufactured from brass (ISO CuZn38Pb2, CuZn39Pb3)
- Standard gear quality: ISO 9 - 10



## Part number structure

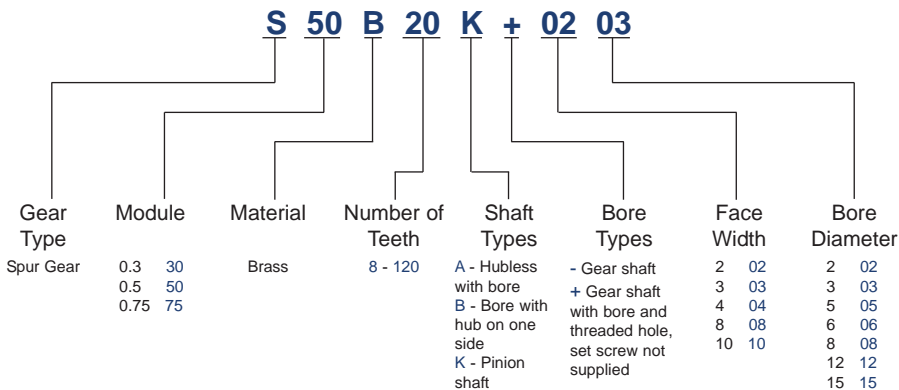

Precision Gears

Additional brass gears are available in the precision gear range - see page 4-6



Associated Products  
Set screws: page 13-1  
Shafts: page 11-2  
Bearings: page 12-1

All dimensions in mm  
Pressure angle 20°

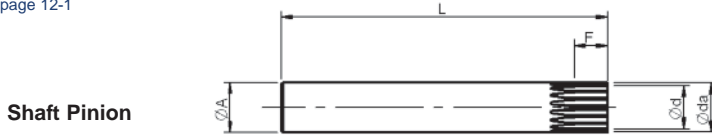

Shaft Pinion

- in part number denotes shaft pinion type

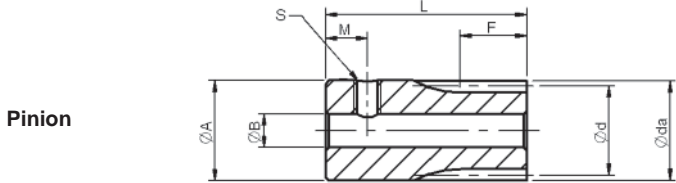

Pinion

### Part number selection table

set screw not supplied

| Part Number  | Module | Number of Teeth | PCD<br>Ød | OD<br>Øda | Bore Dia (H8)<br>ØB | Hub Dia<br>ØA | Face Width<br>F | Overall Length<br>L | Set Screw |     |
|--------------|--------|-----------------|-----------|-----------|---------------------|---------------|-----------------|---------------------|-----------|-----|
|              |        |                 |           |           |                     |               |                 |                     | S         | M   |
| S30B14K+0402 | 0.3    | 14              | 4.2       | 4.8       | 2                   | 5.0           | 4               | 12                  | M1.6      | 2.5 |
| S30B15K+0402 |        | 15              | 4.5       | 5.1       |                     | 5.5           |                 | 12                  | M1.6      | 2.5 |
| S30B16K+0402 |        | 16              | 4.8       | 5.4       |                     | 5.5           |                 | 12                  | M1.6      | 2.5 |
| S30B18K+0402 |        | 18              | 5.4       | 6.0       |                     | 6.0           |                 | 12                  | M2        | 2.5 |
| S50B10K-1006 | 0.5    | 10              | 5.0       | 6.0       | -                   | 6.0           | 10              | 55                  | -         | -   |
| S50B12K-1007 |        | 12              | 6.0       | 7.0       | -                   | 7.0           | 10              | 55                  | -         | -   |
| S50B14K-1008 |        | 14              | 7.0       | 8.0       | -                   | 8.0           | 10              | 55                  | -         | -   |
| S50B15K+0803 |        | 15              | 7.5       | 8.5       | 3                   | 9.0           | 8               | 18                  | M3        | 3.0 |
| S50B16K+0803 |        | 16              | 8.0       | 9.0       | 3                   | 9.0           | 8               | 18                  | M3        | 3.0 |
| S50B18K+0803 |        | 18              | 9.0       | 10.0      | 3                   | 10.0          | 8               | 18                  | M3        | 3.0 |
| S50B20K+0803 |        | 20              | 10.0      | 11.0      | 3                   | 11.0          | 8               | 18                  | M3        | 3.0 |
| S75B10K-0809 | 0.75   | 10              | 7.5       | 9.0       | -                   | 9.0           | 8               | 55                  | -         | -   |
| S75B12K-0811 |        | 12              | 9.0       | 10.5      | -                   | 11.0          |                 | 55                  | -         | -   |
| S75B14K+0805 |        | 14              | 10.5      | 12.0      | 5                   | 12.0          |                 | 20                  | M3        | 3.0 |
| S75B15K+0805 |        | 15              | 11.25     | 12.75     | 5                   | 12.75         |                 | 20                  | M3        | 3.0 |
| S75B16K+0805 |        | 16              | 12.0      | 13.5      | 5                   | 13.5          |                 | 20                  | M3        | 3.0 |
| S75B18K+0805 |        | 18              | 13.5      | 15.0      | 5                   | 15.0          |                 | 20                  | M3        | 3.0 |
| S75B20K+0805 |        | 20              | 15.0      | 16.5      | 5                   | 16.5          |                 | 20                  | M3        | 3.0 |

### Features

- Material: Brass (ISO CuZn39Pb3)
- Gear quality: ISO 9 - 10
- Small quantities of selected items available ex-stock, please visit our on-line store: [www.reliance.co.uk/shop](http://www.reliance.co.uk/shop)

### Technical support

- Allowable backlash - see [page T4-17](#)
- For modified or fully bespoke gears, please contact us
- Product overview - see [page 4-70](#)

Precision Gears



All dimensions in mm  
Pressure angle 20°

**Associated Products**

Set screws: page 13-1

Shafts: page 11-2

Bearings: page 12-1

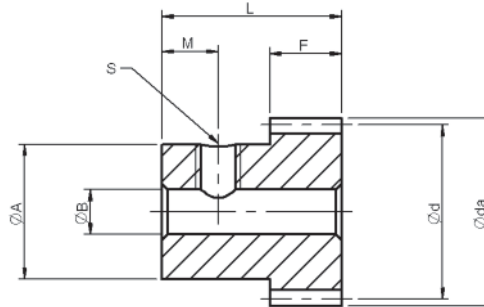
**Part number selection table**

set screw not supplied

| Part Number         | Number of Teeth | PCD  |      | Bore Dia (H8)<br>ØB | Hub Dia<br>ØA | Face Width<br>F | Overall Length<br>L | Set Screw |     |
|---------------------|-----------------|------|------|---------------------|---------------|-----------------|---------------------|-----------|-----|
|                     |                 | Ød   | Øda  |                     |               |                 |                     | S         | M   |
| <b>S30B20B+0302</b> | 20              | 6.0  | 6.6  | 2                   | 5             | 3.2             | 8                   | M1.6      | 2.5 |
| <b>S30B24B+0302</b> | 24              | 7.2  | 7.8  | 2                   | 6             | 3.2             |                     | M2        | 2.5 |
| <b>S30B25B+0302</b> | 25              | 7.5  | 8.1  | 2                   | 6             | 3.2             |                     | M2        | 2.5 |
| <b>S30B28B+0302</b> | 28              | 8.4  | 9.0  | 2                   | 7             | 3.2             |                     | M2        | 2.5 |
| <b>S30B30B+0302</b> | 30              | 9.0  | 9.6  | 2                   | 8             | 3.2             |                     | M2        | 2.5 |
| <b>S30B32B+0202</b> | 32              | 9.6  | 10.2 | 2                   | 8             | 2.0             |                     | M2        | 3.0 |
| <b>S30B35B+0202</b> | 35              | 10.5 | 11.1 | 2                   | 8             | 2.0             |                     | M2        | 3.0 |
| <b>S30B36B+0203</b> | 36              | 10.8 | 11.4 | 3                   | 9             | 2.0             |                     | M3        | 3.0 |
| <b>S30B40B+0203</b> | 40              | 12.0 | 12.6 | 3                   | 10            | 2.0             |                     | M3        | 3.0 |
| <b>S30B45B+0203</b> | 45              | 13.5 | 14.1 | 3                   | 10            | 2.0             |                     | M3        | 3.0 |
| <b>S30B48B+0203</b> | 48              | 14.4 | 15.0 | 3                   | 10            | 2.0             | M3                  | 3.0       |     |

**i Features**

- Material: Brass (ISO CuZn39Pb3)
- Gear quality: ISO 9 - 10
- Small quantities of selected items available ex-stock, please visit our on-line store: [www.reliance.co.uk/shop](http://www.reliance.co.uk/shop)

**? Technical support**

- Allowable backlash - see [page T4-17](#)
- For modified or fully bespoke gears, please contact us
- Product overview - see [page 4-70](#)



**Associated Products**  
 Set screws: page 13-1  
 Shafts: page 11-2  
 Bearings: page 12-1

All dimensions in mm  
 Pressure angle 20°

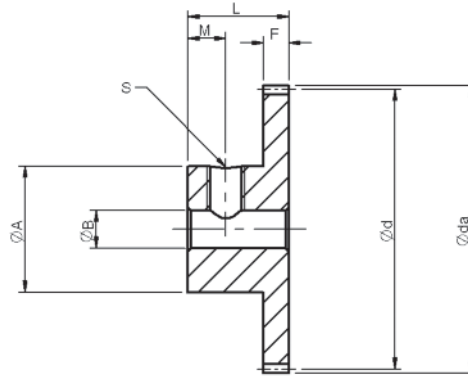

### Part number selection table

set screw not supplied

| Part Number          | Number of Teeth | PCD<br>Ød | OD<br>Øda | Bore Dia (H8)<br>ØB | Hub Dia<br>ØA | Face Width<br>F | Overall Length<br>L | Set Screw |   |
|----------------------|-----------------|-----------|-----------|---------------------|---------------|-----------------|---------------------|-----------|---|
|                      |                 |           |           |                     |               |                 |                     | S         | M |
| <b>S30B50B+0203</b>  | 50              | 15.0      | 15.6      |                     |               |                 |                     |           |   |
| <b>S30B56B+0203</b>  | 56              | 16.8      | 17.4      |                     |               |                 |                     |           |   |
| <b>S30B60B+0203</b>  | 60              | 18.0      | 18.6      |                     |               |                 |                     |           |   |
| <b>S30B64B+0203</b>  | 64              | 19.2      | 19.8      |                     |               |                 |                     |           |   |
| <b>S30B66B+0203</b>  | 66              | 19.8      | 20.4      |                     |               |                 |                     |           |   |
| <b>S30B70B+0203</b>  | 70              | 21.0      | 21.6      |                     |               |                 |                     |           |   |
| <b>S30B72B+0203</b>  | 72              | 21.6      | 22.2      | 3                   | 10            | 2               | 8                   | M3        | 3 |
| <b>S30B75B+0203</b>  | 75              | 22.5      | 23.1      |                     |               |                 |                     |           |   |
| <b>S30B80B+0203</b>  | 80              | 24.0      | 24.6      |                     |               |                 |                     |           |   |
| <b>S30B90B+0203</b>  | 90              | 27.0      | 27.6      |                     |               |                 |                     |           |   |
| <b>S30B96B+0203</b>  | 96              | 28.8      | 29.4      |                     |               |                 |                     |           |   |
| <b>S30B100B+0203</b> | 100             | 30.0      | 30.6      |                     |               |                 |                     |           |   |
| <b>S30B108B+0203</b> | 108             | 32.4      | 33.0      |                     |               |                 |                     |           |   |

### **i** Features

- Material: Brass (ISO CuZn39Pb3)
- Gear quality: ISO 9 - 10
- Small quantities of selected items available ex-stock, please visit our on-line store: [www.reliance.co.uk/shop](http://www.reliance.co.uk/shop)

### **?** Technical support

- Allowable backlash - see [page T4-17](#)
- For modified or fully bespoke gears, please contact us
- Product overview - see [page 4-70](#)

Precision Gears



All dimensions in mm  
Pressure angle 20°

**Associated Products**  
Set screws: page 13-1  
Shafts: page 11-2  
Bearings: page 12-1

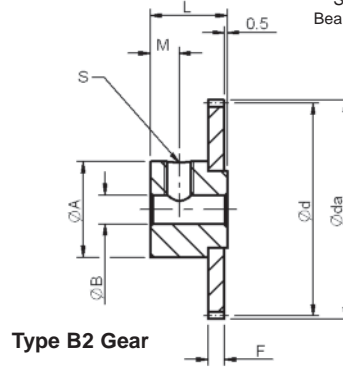
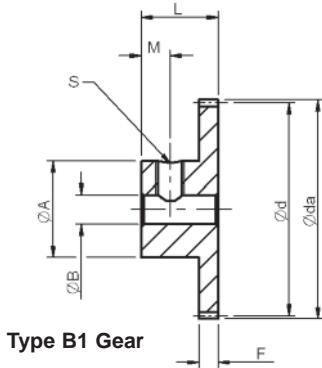

## Part number selection table

set screw not supplied

| Part Number  | Number of Teeth | Type | PCD<br>Ød | OD<br>Øda | Bore Dia (H8)<br>ØB | Hub Dia<br>ØA | Face Width<br>F | Overall Length<br>L | Set Screw |     |
|--------------|-----------------|------|-----------|-----------|---------------------|---------------|-----------------|---------------------|-----------|-----|
|              |                 |      |           |           |                     |               |                 |                     | S         | M   |
| S50B20B+0303 | 20              | B1   | 10.0      | 11.0      | 3                   | 8.2           | 3               | 8                   | M3        | 2.5 |
| S50B24B+0303 | 24              | B1   | 12.0      | 13.0      |                     | 10.0          | 3               | 8                   |           |     |
| S50B25B+0303 | 25              | B1   | 12.5      | 13.5      |                     | 10.0          | 3               | 8                   |           |     |
| S50B26B+0303 | 26              | B1   | 13.0      | 14.0      |                     | 10.0          | 3               | 8                   |           |     |
| S50B28B+0303 | 28              | B1   | 14.0      | 15.0      |                     | 10.0          | 3               | 8                   |           |     |
| S50B30B+0303 | 30              | B1   | 15.0      | 16.0      |                     | 10.0          | 3               | 8                   |           |     |
| S50B32B+0303 | 32              | B1   | 16.0      | 17.0      |                     | 10.0          | 3               | 8                   |           |     |
| S50B35B+0303 | 35              | B1   | 17.5      | 18.5      |                     | 10.0          | 3               | 8                   |           |     |
| S50B36B+0303 | 36              | B1   | 18.0      | 19.0      |                     | 10.0          | 3               | 8                   |           |     |
| S50B40B+0203 | 40              | B2   | 20.0      | 21.0      |                     | 10.0          | 2               | 7.5                 |           |     |
| S50B42B+0203 | 42              | B2   | 21.0      | 22.0      |                     | 10.0          | 2               | 7.5                 |           |     |
| S50B45B+0203 | 45              | B2   | 22.5      | 23.5      |                     | 10.0          | 2               | 7.5                 |           |     |
| S50B48B+0203 | 48              | B2   | 24.0      | 25.0      |                     | 10.0          | 2               | 7.5                 |           |     |
| S50B50B+0203 | 50              | B2   | 25.0      | 26.0      |                     | 10.0          | 2               | 7.5                 |           |     |
| S50B55B+0203 | 55              | B2   | 27.5      | 28.5      |                     | 10.0          | 2               | 7.5                 |           |     |
| S50B56B+0203 | 56              | B2   | 28.0      | 29.0      |                     | 10.0          | 2               | 7.5                 |           |     |
| S50B58B+0203 | 58              | B2   | 29.0      | 30.0      |                     | 10.0          | 2               | 7.5                 |           |     |
| S50B60B+0203 | 60              | B2   | 30.0      | 31.0      |                     | 10.0          | 2               | 7.5                 |           |     |

Type B2 gears have riveted hub

### **i** Features

- Material: Brass (ISO CuZn38Pb2, CuZn39Pb3)
- Gear quality: ISO 9 - 10
- Small quantities of selected items available ex-stock, please visit our on-line store: [www.reliance.co.uk/shop](http://www.reliance.co.uk/shop)

### **?** Technical support

- Allowable backlash - see [page T4-17](#)
- For modified or fully bespoke gears, please contact us
- Product overview - see [page 4-70](#)





**Associated Products**  
 Set screws: page 13-1  
 Shafts: page 11-2  
 Bearings: page 12-1

All dimensions in mm  
 Pressure angle 20°

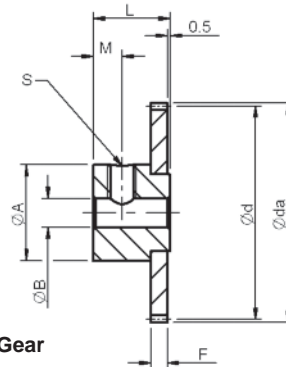

Type B2 Gear

### Part number selection table

set screw not supplied

| Part Number   | Number of Teeth | Type | PCD<br>Ød | OD<br>Øda | Bore Dia (H8)<br>ØB | Hub Dia<br>ØA | Face Width<br>F | Overall Length<br>L | Set Screw |     |
|---------------|-----------------|------|-----------|-----------|---------------------|---------------|-----------------|---------------------|-----------|-----|
|               |                 |      |           |           |                     |               |                 |                     | S         | M   |
| S50B62B+0203  | 62              | B2   | 31.0      | 32.0      | 3                   | 10.0          | 2               | 7.5                 | M3        | 2.5 |
| S50B64B+0203  | 64              | B2   | 32.0      | 33.0      |                     | 10.0          |                 | 7.5                 |           | 2.5 |
| S50B65B+0203  | 65              | B2   | 32.5      | 33.5      |                     | 10.0          |                 | 7.5                 |           | 2.5 |
| S50B68B+0203  | 68              | B2   | 34.0      | 35.0      |                     | 10.0          |                 | 7.5                 |           | 2.5 |
| S50B70B+0203  | 70              | B2   | 35.0      | 36.0      |                     | 10.0          |                 | 7.5                 |           | 2.5 |
| S50B72B+0203  | 72              | B2   | 36.0      | 37.0      |                     | 10.0          |                 | 7.5                 |           | 2.5 |
| S50B75B+0203  | 75              | B2   | 37.5      | 38.5      |                     | 10.0          |                 | 7.5                 |           | 2.5 |
| S50B80B+0203  | 80              | B2   | 40.0      | 41.0      |                     | 10.0          |                 | 7.5                 |           | 2.5 |
| S50B84B+0203  | 84              | B2   | 42.0      | 43.0      |                     | 10.0          |                 | 7.5                 |           | 2.5 |
| S50B85B+0203  | 85              | B2   | 42.5      | 43.5      |                     | 10.0          |                 | 7.5                 |           | 2.5 |
| S50B90B+0203  | 90              | B2   | 45.0      | 46.0      |                     | 10.0          |                 | 7.5                 |           | 2.5 |
| S50B95B+0203  | 95              | B2   | 47.5      | 48.5      |                     | 10.0          |                 | 7.5                 |           | 2.5 |
| S50B100B+0203 | 100             | B2   | 50.0      | 51.0      |                     | 15.0          |                 | 9.5                 |           | 3.5 |
| S50B105B+0203 | 105             | B2   | 52.5      | 53.5      |                     | 15.0          |                 | 9.5                 |           | 3.5 |
| S50B110B+0203 | 110             | B2   | 55.0      | 56.0      |                     | 15.0          |                 | 9.5                 |           | 3.5 |

Type B2 gears have riveted hub

### Features

- Material: Brass (ISO CuZn38Pb2, CuZn39Pb3)
- Gear quality: ISO 9 - 10
- Small quantities of selected items available ex-stock, please visit our on-line store: [www.reliance.co.uk/shop](http://www.reliance.co.uk/shop)

### Technical support

- Allowable backlash - see [page T4-17](#)
- For modified or fully bespoke gears, please contact us
- Product overview - see [page 4-70](#)

Precision Gears



All dimensions in mm  
Pressure angle 20°

**Associated Products**  
Set screws: page 13-1  
Shafts: page 11-2  
Bearings: page 12-1

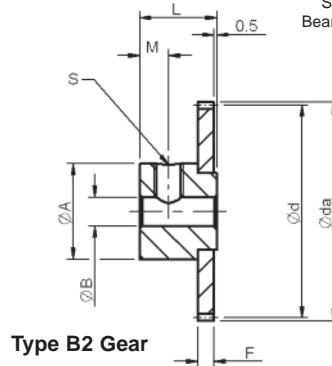
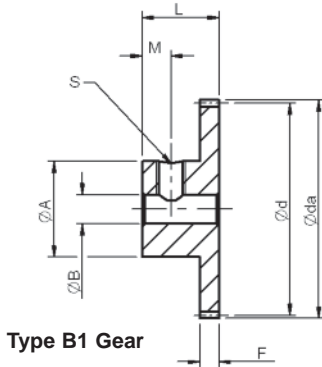

## Part number selection table

set screw not supplied

| Part Number  | Number of Teeth | Type | PCD<br>Ød | OD<br>Øda | Bore Dia (H8)<br>ØB | Hub Dia<br>ØA | Face Width<br>F | Overall Length<br>L | Set Screw |     |
|--------------|-----------------|------|-----------|-----------|---------------------|---------------|-----------------|---------------------|-----------|-----|
|              |                 |      |           |           |                     |               |                 |                     | S         | M   |
| S75B16B+0305 | 16              | B1   | 12.0      | 13.5      | 5                   | 10.0          |                 | 10.0                | M3        |     |
| S75B18B+0305 | 18              | B1   | 13.5      | 15.0      | 5                   | 11.0          |                 | 10.0                | M3        |     |
| S75B20B+0306 | 20              | B1   | 15.0      | 16.5      | 6                   | 12.0          |                 | 10.0                | M4        |     |
| S75B24B+0306 | 24              | B1   | 18.0      | 19.5      | 6                   | 14.0          |                 | 10.0                | M4        |     |
| S75B25B+0306 | 25              | B1   | 18.75     | 20.25     | 6                   | 14.0          |                 | 10.0                | M4        |     |
| S75B26B+0306 | 26              | B1   | 19.5      | 21.0      | 6                   | 14.0          |                 | 10.0                | M4        |     |
| S75B28B+0306 | 28              | B1   | 21.0      | 22.5      | 6                   | 14.0          |                 | 10.0                | M4        |     |
| S75B30B+0306 | 30              | B1   | 22.5      | 24.0      | 6                   | 15.0          |                 | 10.0                | M4        |     |
| S75B32B+0306 | 32              | B1   | 24.0      | 25.5      | 6                   | 15.0          |                 | 10.0                | M4        |     |
| S75B35B+0306 | 35              | B1   | 26.25     | 27.75     | 6                   | 18.0          | 3               | 10.0                | M4        | 3.5 |
| S75B36B+0306 | 36              | B1   | 27.0      | 28.5      | 6                   | 18.0          |                 | 10.0                | M4        |     |
| S75B40B+0306 | 40              | B1   | 30.0      | 31.5      | 6                   | 20.0          |                 | 10.0                | M4        |     |
| S75B42B+0306 | 42              | B1   | 31.5      | 33.0      | 6                   | 20.0          |                 | 10.0                | M4        |     |
| S75B45B+0306 | 45              | B1   | 33.75     | 35.25     | 6                   | 20.0          |                 | 10.0                | M4        |     |
| S75B48B+0306 | 48              | B1   | 36.0      | 37.5      | 6                   | 20.0          |                 | 10.0                | M4        |     |
| S75B50B+0306 | 50              | B2   | 37.5      | 39.0      | 6                   | 20.0          |                 | 10.5                | M4        |     |
| S75B55B+0306 | 55              | B2   | 41.25     | 42.75     | 6                   | 20.0          |                 | 10.5                | M4        |     |
| S75B56B+0306 | 56              | B2   | 42.0      | 43.5      | 6                   | 20.0          |                 | 10.5                | M4        |     |
| S75B58B+0306 | 58              | B2   | 43.5      | 45.0      | 6                   | 20.0          |                 | 10.5                | M4        |     |

Type B2 gears have riveted hub

### **i** Features

- Material: Brass (ISO CuZn38Pb2, CuZn39Pb3)
- Gear quality: ISO 9 - 10
- Small quantities of selected items available ex-stock, please visit our on-line store: [www.reliance.co.uk/shop](http://www.reliance.co.uk/shop)

### **?** Technical support

- Allowable backlash - see [page T4-17](#)
- For modified or fully bespoke gears, please contact us
- Product overview - see [page 4-70](#)



**Associated Products**  
 Set screws: page 13-1  
 Shafts: page 11-2  
 Bearings: page 12-1

All dimensions in mm  
 Pressure angle 20°

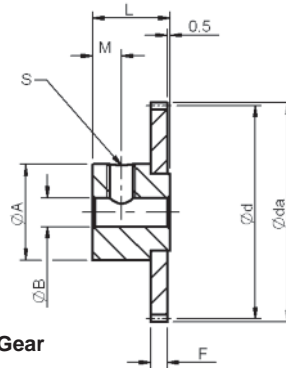

Type B2 Gear

### Part number selection table

set screw not supplied

| Part Number                   | Number of Teeth | Type | PCD<br>$\varnothing d$ | OD<br>$\varnothing da$ | Bore Dia (H8)<br>$\varnothing B$ | Hub Dia<br>$\varnothing A$ | Face Width<br>F | Overall Length<br>L | Set Screw |     |
|-------------------------------|-----------------|------|------------------------|------------------------|----------------------------------|----------------------------|-----------------|---------------------|-----------|-----|
|                               |                 |      |                        |                        |                                  |                            |                 |                     | S         | M   |
| <a href="#">S75B60B+0306</a>  | 60              | B2   | 45.0                   | 46.5                   |                                  |                            |                 |                     |           |     |
| <a href="#">S75B62B+0306</a>  | 62              | B2   | 46.5                   | 48.0                   |                                  |                            |                 |                     |           |     |
| <a href="#">S75B64B+0306</a>  | 64              | B2   | 48.0                   | 49.5                   |                                  |                            |                 |                     |           |     |
| <a href="#">S75B65B+0306</a>  | 65              | B2   | 48.75                  | 50.25                  |                                  |                            |                 |                     |           |     |
| <a href="#">S75B66B+0306</a>  | 66              | B2   | 49.5                   | 51.0                   |                                  |                            |                 |                     |           |     |
| <a href="#">S75B68B+0306</a>  | 68              | B2   | 51.0                   | 52.5                   |                                  |                            |                 |                     |           |     |
| <a href="#">S75B70B+0306</a>  | 70              | B2   | 52.5                   | 54.0                   |                                  |                            |                 |                     |           |     |
| <a href="#">S75B72B+0306</a>  | 72              | B2   | 54.0                   | 55.5                   |                                  |                            |                 |                     |           |     |
| <a href="#">S75B75B+0306</a>  | 75              | B2   | 56.25                  | 57.75                  | 6                                | 20.0                       | 3               | 10.5                | M4        | 3.5 |
| <a href="#">S75B80B+0306</a>  | 80              | B2   | 60.0                   | 61.5                   |                                  |                            |                 |                     |           |     |
| <a href="#">S75B85B+0306</a>  | 85              | B2   | 63.75                  | 65.25                  |                                  |                            |                 |                     |           |     |
| <a href="#">S75B90B+0306</a>  | 90              | B2   | 67.5                   | 69.0                   |                                  |                            |                 |                     |           |     |
| <a href="#">S75B95B+0306</a>  | 95              | B2   | 71.25                  | 72.75                  |                                  |                            |                 |                     |           |     |
| <a href="#">S75B100B+0306</a> | 100             | B2   | 75.0                   | 76.5                   |                                  |                            |                 |                     |           |     |
| <a href="#">S75B105B+0306</a> | 105             | B2   | 78.75                  | 80.25                  |                                  |                            |                 |                     |           |     |
| <a href="#">S75B110B+0306</a> | 110             | B2   | 82.5                   | 84.0                   |                                  |                            |                 |                     |           |     |
| <a href="#">S75B115B+0306</a> | 115             | B2   | 86.25                  | 87.75                  |                                  |                            |                 |                     |           |     |
| <a href="#">S75B120B+0306</a> | 120             | B2   | 90.0                   | 91.5                   |                                  |                            |                 |                     |           |     |

Type B2 gears have riveted hub

### **i** Features

- Material: Brass (ISO CuZn38Pb2, CuZn39Pb3)
- Gear quality: ISO 9 - 10
- Small quantities of selected items available ex-stock, please visit our on-line store: [www.reliance.co.uk/shop](http://www.reliance.co.uk/shop)

### **?** Technical support

- Allowable backlash - see [page T4-17](#)
- For modified or fully bespoke gears, please contact us
- Product overview - see [page 4-70](#)

Precision Gears



All dimensions in mm  
Pressure angle 20°

**Associated Products**  
Gears: page 4-1  
Shafts: page 11-2

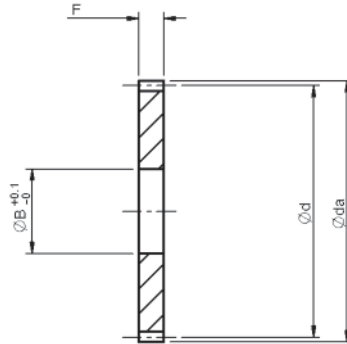

### Part number selection table

| Part Number  | Number of Teeth | PCD  |      | Face Width F | Bore Dia ØB |
|--------------|-----------------|------|------|--------------|-------------|
|              |                 | Ød   | Øda  |              |             |
| S50B40A-0208 | 40              | 20.0 | 21.0 | 2            | 8           |
| S50B42A-0208 | 42              | 21.0 | 22.0 |              |             |
| S50B45A-0208 | 45              | 22.5 | 23.5 |              |             |
| S50B48A-0208 | 48              | 24.0 | 25.0 |              |             |
| S50B50A-0208 | 50              | 25.0 | 26.0 |              |             |
| S50B55A-0208 | 55              | 27.5 | 28.5 |              |             |
| S50B56A-0208 | 56              | 28.0 | 29.0 |              |             |
| S50B58A-0208 | 58              | 29.0 | 30.0 |              |             |
| S50B60A-0208 | 60              | 30.0 | 31.0 |              |             |
| S50B62A-0208 | 62              | 31.0 | 32.0 |              |             |
| S50B64A-0208 | 64              | 32.0 | 33.0 |              |             |
| S50B65A-0208 | 65              | 32.5 | 33.5 |              |             |

Precision Gears

### Features

- Material: Brass (ISO CuZn38Pb2, CuZn39Pb3)
- Gear quality: ISO 9 - 10
- Small quantities of selected items available ex-stock, please visit our on-line store: [www.reliance.co.uk/shop](http://www.reliance.co.uk/shop)

### Technical support

- Allowable backlash - see [page T4-17](#)
- For modified or fully bespoke gears, please contact us
- Product overview - see [page 4-70](#)



**Associated Products**  
Gears: page 4-1  
Shafts: page 11-2

All dimensions in mm  
Pressure angle 20°

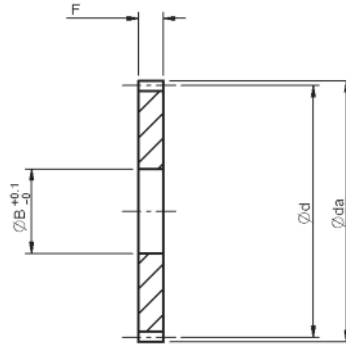

### Part number selection table

| Part Number   | Number of Teeth | PCD<br>Ød | OD<br>Øda | Face Width<br>F | Bore Dia<br>ØB |
|---------------|-----------------|-----------|-----------|-----------------|----------------|
| S50B68A-0208  | 68              | 34.0      | 35.0      | 2               | 8              |
| S50B70A-0208  | 70              | 35.0      | 36.0      |                 | 8              |
| S50B72A-0208  | 72              | 36.0      | 37.0      |                 | 8              |
| S50B75A-0208  | 75              | 37.5      | 38.5      |                 | 8              |
| S50B80A-0208  | 80              | 40.0      | 41.0      |                 | 8              |
| S50B84A-0208  | 84              | 42.0      | 43.0      |                 | 8              |
| S50B85A-0208  | 85              | 42.5      | 43.5      |                 | 8              |
| S50B90A-0208  | 90              | 45.0      | 46.0      |                 | 8              |
| S50B95A-0208  | 95              | 47.5      | 48.5      |                 | 8              |
| S50B100A-0212 | 100             | 50.0      | 51.0      |                 | 12             |
| S50B105A-0212 | 105             | 52.5      | 53.5      |                 | 12             |
| S50B110A-0212 | 110             | 55.0      | 56.0      |                 | 12             |

Precision Gears

### Features

- Material: Brass (ISO CuZn38Pb2, CuZn39Pb3)
- Gear quality: ISO 9 - 10
- Small quantities of selected items available ex-stock, please visit our on-line store: [www.reliance.co.uk/shop](http://www.reliance.co.uk/shop)

### Technical support

- Allowable backlash - see [page T4-17](#)
- For modified or fully bespoke gears, please contact us
- Product overview - see [page 4-70](#)



All dimensions in mm  
Pressure angle 20°

Associated Products  
Gears: page 4-1

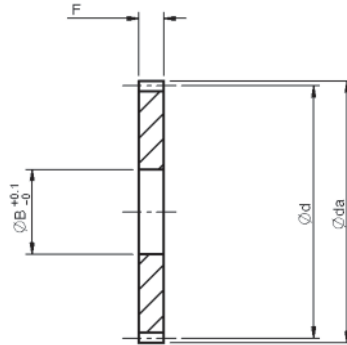

### Part number selection table

| Part Number  | Number of Teeth | PCD<br>$\phi d$ | OD<br>$\phi da$ | Face Width<br>F | Bore Dia<br>$\phi B$ |
|--------------|-----------------|-----------------|-----------------|-----------------|----------------------|
| S75B50A-0315 | 50              | 37.5            | 39.0            | 3               | 15                   |
| S75B55A-0315 | 55              | 41.25           | 42.75           |                 |                      |
| S75B56A-0315 | 56              | 42.0            | 43.5            |                 |                      |
| S75B58A-0315 | 58              | 43.5            | 45.0            |                 |                      |
| S75B60A-0315 | 60              | 45.0            | 46.5            |                 |                      |
| S75B62A-0315 | 62              | 46.5            | 48.0            |                 |                      |
| S75B64A-0315 | 64              | 48.0            | 49.5            |                 |                      |
| S75B65A-0315 | 65              | 48.75           | 50.25           |                 |                      |
| S75B66A-0315 | 66              | 49.5            | 51.0            |                 |                      |
| S75B68A-0315 | 68              | 51.0            | 52.5            |                 |                      |
| S75B70A-0315 | 70              | 52.5            | 54.0            |                 |                      |
| S75B72A-0315 | 72              | 54.0            | 55.5            |                 |                      |

Precision Gears

### Features

- Material: Brass (ISO CuZn38Pb2, CuZn39Pb3)
- Gear quality: ISO 9 - 10
- Small quantities of selected items available ex-stock, please visit our on-line store: [www.reliance.co.uk/shop](http://www.reliance.co.uk/shop)

### Technical support

- Allowable backlash - see [page T4-17](#)
- For modified or fully bespoke gears, please contact us
- Product overview - see [page 4-70](#)



Associated Products  
Gears: page 4-1

All dimensions in mm  
Pressure angle 20°

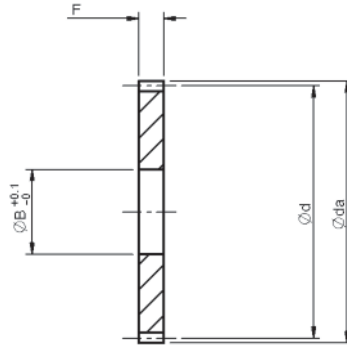

### Part number selection table

| Part Number   | Number of Teeth | PCD<br>$\text{Ø}d$ | OD<br>$\text{Ø}da$ | Face Width<br>F | Bore Dia<br>$\text{Ø}B$ |
|---------------|-----------------|--------------------|--------------------|-----------------|-------------------------|
| S75B75A-0315  | 75              | 56.25              | 57.75              | 3               | 15                      |
| S75B80A-0315  | 80              | 60.0               | 61.5               |                 |                         |
| S75B85A-0315  | 85              | 63.75              | 65.25              |                 |                         |
| S75B90A-0315  | 90              | 67.5               | 69.0               |                 |                         |
| S75B95A-0315  | 95              | 71.25              | 72.75              |                 |                         |
| S75B100A-0315 | 100             | 75.0               | 76.5               |                 |                         |
| S75B105A-0315 | 105             | 78.75              | 80.25              |                 |                         |
| S75B110A-0315 | 110             | 82.5               | 84.0               |                 |                         |
| S75B115A-0315 | 115             | 86.25              | 87.75              |                 |                         |
| S75B120A-0315 | 120             | 90.0               | 91.5               |                 |                         |

Precision Gears

### Features

- Material: Brass (ISO CuZn38Pb2, CuZn39Pb3)
- Gear quality: ISO 9 - 10
- Small quantities of selected items available ex-stock, please visit our on-line store: [www.reliance.co.uk/shop](http://www.reliance.co.uk/shop)

### Technical support

- Allowable backlash - see [page T4-17](#)
- For modified or fully bespoke gears, please contact us
- Product overview - see [page 4-70](#)





# Section Contents

Product Range - Overview.....Page 5-2

Precision Worms and Wheels .....Page 5-3

Worms and Wheels.....Page 5-6

Precision Bevel Gears .....Page 5-8

Mitre Bevel Gears .....Page 5-11

Bevel Gears .....Page 5-13

Brass Bevel Gears .....Page 5-14

Brass Internal Gears .....Page 5-15

Technical Information.....Page T4-1

# Worms and Wheels, Bevels and Internal Gears



## Worms, bevels and internal gears

Reliance offers a range of worms and wheels, bevel and internal gears that are designed to complement our spur gear range by offering additional motion options. As with the spur gears these gears are offered as precision grade in stainless steel and brass as a more economical alternative for less demanding applications.

### Worms and wheels

Worm and wheel drives provide high ratio right angled motion in a small space. Both precision cut and precision cold rolled worms are available (refer to the features, options and technical information on the individual product pages). In general, for more accurate applications the precision cut worms will give the best results and for applications requiring a little more torque transmission precision rolled worms should be used.



Please note that this catalogue only shows a limited range of worms and wheels. Reliance has the ability to cut worms and wheels from 0.2 module up to 1 module; please contact us for requirements for special variants.

### Bevel gears

Bevel gears are more efficient than worms and wheels for right angle drives, but they are typically used for lower ratio applications; if high ratios are required a spur gear reduction stage can be incorporated. Typically shaft angles of 90 degrees are used but other angles are possible – please contact us to discuss your application.



As with the worms and wheels, bevel gears are available in stainless steel and brass; the stainless steel option being higher precision than the brass option. It is important to note that with the bevel gears, where two gears are shown on the page the part number refers to the gear pair. Where only one gear is shown on the page the part number applies to individual gears only – for a pair, two gears must be ordered.

### Internal gears

A small range of brass internal gears is offered for use with the brass gear range.





**Associated Products**  
 Set screws: page 13-11  
 Shafts: page 11-2  
 Bearings: page 12-1

All dimensions in mm  
 Pressure angle 20°

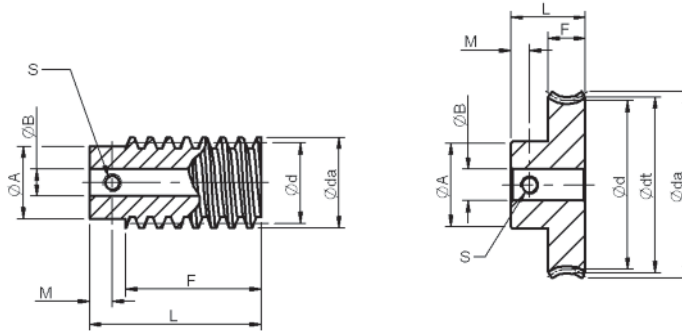

### Part number selection tables

#### Worm

Set screw supplied

| Part Number      | Number of Starts | Thread Direction | PCD<br>Ød | OD<br>Øda | Bore Dia (H8)<br>ØB | Hub Dia<br>ØA | Face Width<br>F | Overall Length<br>L | Lead Angle | Set Screw |     |
|------------------|------------------|------------------|-----------|-----------|---------------------|---------------|-----------------|---------------------|------------|-----------|-----|
|                  |                  |                  |           |           |                     |               |                 |                     |            | S         | M   |
| <b>W50SUR1+B</b> | 1                | Right            | 9         | 10        | 3                   | 7.6           | 13              | 18                  | 3°11'      | M2.5      | 2.5 |

#### Wormwheel

Set screw supplied

| Part Number      | Number of Teeth | Throat Dia<br>Ødt | PCD<br>Ød | Add Mod Coef<br>x | OD<br>Øda | Bore Dia (H8)<br>ØB | Hub Dia<br>ØA | Face Width<br>F | Overall Length<br>L | Set Screw |   |
|------------------|-----------------|-------------------|-----------|-------------------|-----------|---------------------|---------------|-----------------|---------------------|-----------|---|
|                  |                 |                   |           |                   |           |                     |               |                 |                     | S         | M |
| <b>G50B20+R1</b> | 20              | 11                | 10        | -0.015            | 11.3      | 3                   | 9             | 5               | 11                  | M3        | 3 |
| <b>G50B30+R1</b> | 30              | 16                | 15        | -0.023            | 16.3      | 4                   | 12            |                 | 11                  | M3        | 3 |
| <b>G50B40+R1</b> | 40              | 21                | 20        | -0.031            | 21.3      | 5                   | 15            |                 | 13                  | M4        | 4 |
| <b>G50B50+R1</b> | 50              | 26                | 25        | -0.038            | 26.3      | 5                   | 16            |                 | 13                  | M4        | 4 |

Dimension x: Negative modification to allow for use of standard centres

#### **i** Features

- Worm material: Stainless steel SUS304, precision cold rolled
- Wormwheel material: Brass CuZn39Pb3
- Single start worm, right hand thread

#### **?** Technical support

- Worm gear formulae - see [page T4-19](#)
- Backlash at nominal centres - see [page T4-17](#)
- For modified or fully bespoke worms and wheels, please contact us
- Product overview - see [page 5-2](#)



All dimensions in mm  
Pressure angle 20°

**Associated Products**  
Set screws: page 13-11  
Shafts: page 11-2  
Bearings: page 12-1

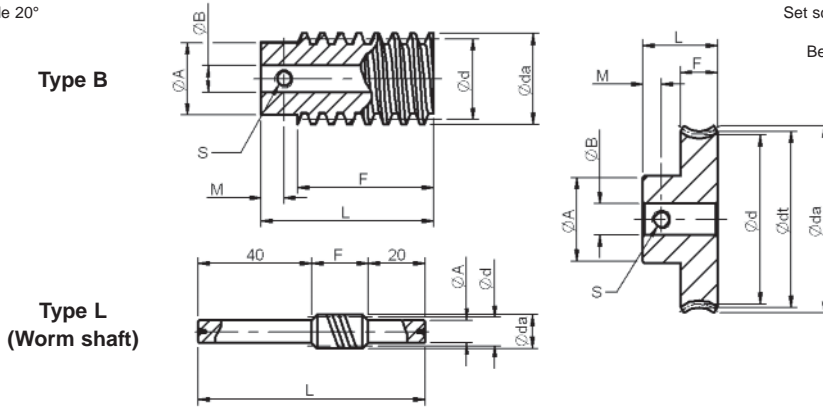

**Part number selection tables**

**Worm**

Set screw not supplied

| Part Number                          | Number of Starts | Thread Direction | PCD  | OD  | Bore Dia (H8) | Hub Dia         | Face Width | Overall Length | Lead Angle | Set Screw |        |
|--------------------------------------|------------------|------------------|------|-----|---------------|-----------------|------------|----------------|------------|-----------|--------|
|                                      |                  |                  | Ød   | Øda | ØB            | ØA              | F          | L              |            | S         | M      |
| <b>W80SUR1+B</b><br><b>W80SUR1-L</b> | 1                | Right            | 10.4 | 12  | 5<br>-        | 10.3<br>8.0(h9) | 14<br>20   | 26<br>80       | 4°24'      | M3<br>-   | 3<br>- |

the dash (-L) in part number denotes worm shaft type

**Wormwheel**

Set screw supplied

| Part Number      | Number of Teeth | Throat Dia | PCD | Add Mod Coef | OD   | Bore Dia (H8) | Hub Dia | Face Width | Overall Length | Set Screw |   |
|------------------|-----------------|------------|-----|--------------|------|---------------|---------|------------|----------------|-----------|---|
|                  |                 | Ødt        | Ød  | x            | Øda  | ØB            | ØA      | F          | L              | S         | M |
| <b>G80A20+R1</b> | 20              | 17.6       | 16  | -0.029       | 18.1 | 5             | 12      | 6          | 12             | M3        | 3 |
| <b>G80A30+R1</b> | 30              | 25.6       | 24  | -0.044       | 26.1 | 5             | 16      |            | 12             | M3        | 3 |
| <b>G80A40+R1</b> | 40              | 33.6       | 32  | -0.059       | 34.1 | 6             | 18      |            | 14             | M4        | 4 |
| <b>G80A50+R1</b> | 50              | 41.6       | 40  | -0.074       | 42.1 | 6             | 20      |            | 14             | M4        | 4 |

Dimension x: Negative modification to allow for use of standard centres

**Features**

- Worm material: Stainless steel SUS304, precision cold rolled
- Wormwheel material: Aluminium bronze casting JIS CAC702
- Single start worm, right hand thread
- Wormwheel suited to right hand, single thread worm

**Technical support**

- Worm gear formulae - see page T4-19
- Backlash at nominal centres - see page T4-17
- For modified or fully bespoke worms and wheels, please contact us
- Product overview - see page 5-2



**Associated Products**  
 Set screws: page 13-11  
 Shafts: page 11-2  
 Bearings: page 12-1

All dimensions in mm  
 Pressure angle 20°

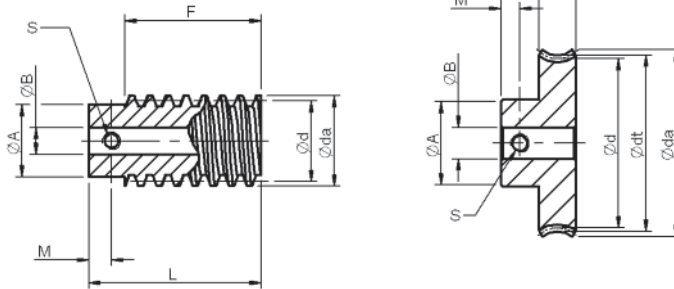

## Part number selection tables

### Worm

Set screw not supplied

| Part Number | Number of Starts | Thread Direction | PCD<br>Ød | OD<br>Øda | Bore Dia (H8)<br>ØB | Hub Dia<br>ØA | Face Width<br>F | Overall Length<br>L | Lead Angle     | Set Screw |     |
|-------------|------------------|------------------|-----------|-----------|---------------------|---------------|-----------------|---------------------|----------------|-----------|-----|
|             |                  |                  |           |           |                     |               |                 |                     |                | S         | M   |
| W1SUR1+B    | 1                | Right            | 16        | 18        | 6                   | 15.85         | 15.5<br>15.0    | 32                  | 3°35'<br>7°11' | M4        | 3.5 |
| W1SUR2+B    | 2                |                  |           |           |                     |               |                 |                     |                |           |     |

### Wormwheel

Set screw supplied

| Part Number | Number of Teeth | Throat Dia<br>Ødt | PCD<br>Ød | Add Mod Coef<br>x | OD<br>Øda | Bore Dia (H8)<br>ØB | Hub Dia<br>ØA | Face Width<br>F | Overall Length<br>L | Set Screw |   |
|-------------|-----------------|-------------------|-----------|-------------------|-----------|---------------------|---------------|-----------------|---------------------|-----------|---|
|             |                 |                   |           |                   |           |                     |               |                 |                     | S         | M |
| G1A20R1+6   | 20              | 22                | 20        | -0.019            | 23.5      | 6                   | 17            | 10              | 18                  | M5        | 4 |
| G1A30R1+6   | 30              | 32                | 30        | -0.029            | 33.5      | 6                   | 22            |                 |                     |           |   |
| G1A40R1+8   | 40              | 42                | 40        | -0.039            | 43.5      | 8                   | 25            | 10              | 18                  | M5        | 4 |
| G1A50R1+8   | 50              | 52                | 50        | -0.048            | 53.5      | 8                   | 30            |                 |                     |           |   |
| G1A20R2+6   | 20              | 22                | 20        | -0.079            | 23.5      | 6                   | 17            | 10              | 18                  | M5        | 4 |
| G1A30R2+6   | 30              | 32                | 30        | -0.118            | 33.5      | 6                   | 22            |                 |                     |           |   |
| G1A40R2+8   | 40              | 42                | 40        | -0.158            | 43.5      | 8                   | 25            | 10              | 18                  | M5        | 4 |
| G1A50R2+8   | 50              | 52                | 50        | -0.197            | 53.5      | 8                   | 30            |                 |                     |           |   |

Dimension x: Negative modification to allow for use of standard centres

### **i** Features and options

- Worm material: Stainless steel SUS304, precision cold rolled
- Wormwheel material: Aluminium bronze casting JIS CAC702
- Single **(R1)** and double **(R2)** start worm, right hand thread
- Left hand thread direction available, replace R with L in the part number

### **?** Technical support

- Worm gear formulae - see page T4-19
- Backlash at nominal centres - see page T4-17
- For modified or fully bespoke worms and wheels, please contact us
- Product overview - see page 5-2



All dimensions in mm  
General tolerances  $\pm 0.13$  mm

**Associated Products**  
Set screws: page 13-11  
Shafts: page 11-2  
Bearings: page 12-1

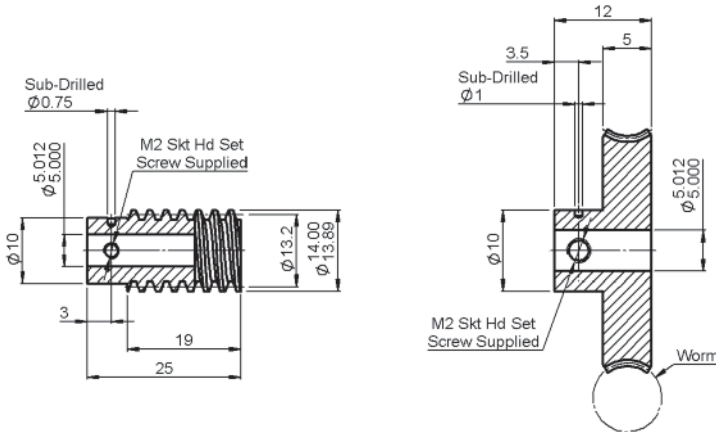

### Part number selection tables

| Worm        |               |
|-------------|---------------|
| Lead Angle  | 1° 44'        |
| Lead        | 1.257         |
| P.A.        | 14.5°         |
| Part Number | <b>WGS-5S</b> |

| Wormwheel           | Dimensions      |                |
|---------------------|-----------------|----------------|
| Part Number         | Number of Teeth | Pitch Diameter |
| <b>Single Start</b> |                 |                |
| <b>WGB83-S40</b>    | 40              | 16.00          |
| <b>WGB83-S50</b>    | 50              | 20.00          |
| <b>WGB83-S60</b>    | 60              | 24.00          |
| <b>WGB83-S70</b>    | 70              | 28.00          |
| <b>WGB83-S80</b>    | 80              | 32.00          |
| <b>WGB83-S90</b>    | 90              | 36.00          |
| <b>WGB83-S100</b>   | 100             | 40.00          |
| <b>WGB83-S110</b>   | 110             | 44.00          |
| <b>WGB83-S120</b>   | 120             | 48.00          |

Worms and Wheels

### **i** Features and options

- Gear quality AQ10 - see page T4-1
- Worm material: Stainless steel (DIN 1.4305)
- Wormwheel material: Naval brass QQ-B-637
- Anti-backlash wormwheels available
- Alternative number of starts available

### **?** Technical support

- Worm gear formulae - see page T4-19
- For modified or fully bespoke worms and wheels, please contact us
- Product overview - see page 5-2



**Associated Products**  
 Set screws: page 13-11  
 Shafts: page 11-2  
 Bearings: page 12-1

All dimensions in mm  
 General tolerances  $\pm 0.13$  mm

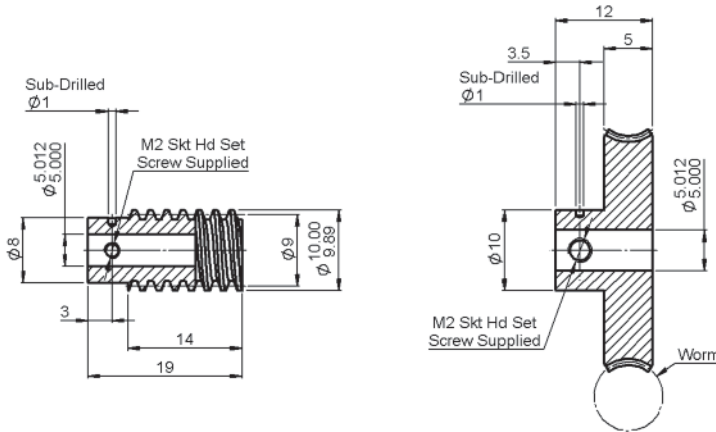

### Part number selection tables

| Worm        |               |
|-------------|---------------|
| Lead Angle  | 3° 10'        |
| Lead        | 1.571         |
| P.A.        | 14.5°         |
| Part Number | <b>WFS-5S</b> |

| Wormwheel           | Dimensions      |                |
|---------------------|-----------------|----------------|
| Part Number         | Number of Teeth | Pitch Diameter |
| <b>Single Start</b> |                 |                |
| WFB83-S30           | 30              | 15.00          |
| WFB83-S40           | 40              | 20.00          |
| WFB83-S50           | 50              | 25.00          |
| WFB83-S60           | 60              | 30.00          |
| WFB83-S70           | 70              | 35.00          |
| WFB83-S80           | 80              | 40.00          |
| WFB83-S90           | 90              | 45.00          |
| WFB83-S100          | 100             | 50.00          |
| WFB83-S120          | 120             | 60.00          |

### **i** Features and options

- Gear quality AQ10 - see page T4-1
- Worm material: Stainless steel (DIN 1.4305)
- Wormwheel material: Naval brass QQ-B-637
- Anti-backlash wormwheels available
- Alternative number of starts available

### **?** Technical support

- Worm gear formulae - see page T4-19
- For modified or fully bespoke worms and wheels, please contact us
- Product overview - see page 5-2



# 0.4 Module 4 mm Bore

# Precision Bevel Gears

All dimensions in mm  
 General tolerances  $\pm 0.13$  mm  
 Pressure angle  $20^\circ$   
 Material: Stainless steel 303

**Associated Products**  
 Set screws: page 13-11  
 Shafts: page 11-2  
 Bearings: page 12-1

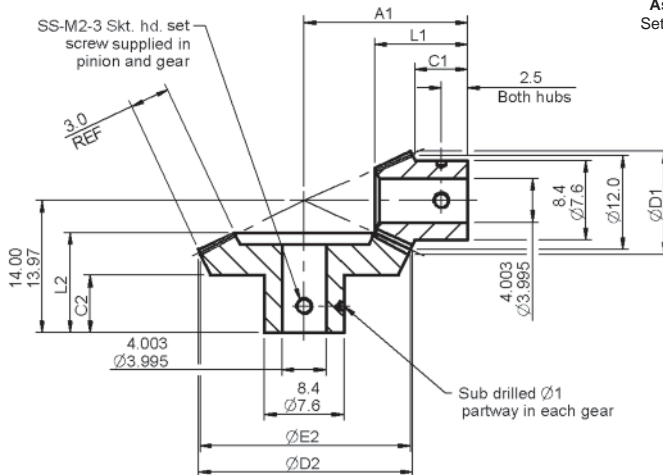

## Part number selection table

Gears supplied as a pair

| Part Number (pair) | Ratio | Module | Number of Teeth |      | Max. TTCE (pair) | Max. TCE (pair) |
|--------------------|-------|--------|-----------------|------|------------------|-----------------|
|                    |       |        | Pinion          | Gear |                  |                 |
| M04N-1S            | 1:1   | 0.4    | 30              | 30   | 0.025            | 0.050           |
| M04N-2S            | 2:1   |        | 30              | 60   |                  |                 |
| M04N-3S            | 3:1   |        | 30              | 90   |                  |                 |
| M04N-4S            | 4:1   |        | 30              | 120  |                  |                 |

## Dimension table

| Part Number (pair) | Overall Length $\pm 0.15$ |         | Outside Dia $+0.00 / -0.05$ |                       | Pitch Dia | Hub Length $\pm 0.25$ |           | Distance to Apex $+0.00 / -0.03$ |
|--------------------|---------------------------|---------|-----------------------------|-----------------------|-----------|-----------------------|-----------|----------------------------------|
|                    | Pinion L1                 | Gear L2 | Pinion $\varnothing D1$     | Gear $\varnothing D2$ |           | Gear $\varnothing E2$ | Pinion C1 |                                  |
| M04N-1S            | 10.28                     | 10.28   | 12.56                       | 12.56                 | 12.0      | 6.00                  | 6.00      | 14.00                            |
| M04N-2S            | 9.86                      | 9.50    | 12.96                       | 24.23                 | 24.0      | 6.00                  | 5.00      | 19.00                            |
| M04N-3S            | 9.00                      | 9.13    | 13.07                       | 36.15                 | 36.0      | 5.33                  | 5.00      | 24.00                            |
| M04N-4S            | 8.03                      | 8.91    | 13.11                       | 48.11                 | 48.0      | 4.50                  | 5.00      | 29.00                            |

Worms and  
Wheels

### Features

- Gleason system
- Precision bevel gears supplied as a pair

### Technical support

- For modified or fully bespoke gears, please contact us
- Product overview - see page 5-2





**Associated Products**  
 Set screws: page 13-11  
 Shafts: page 11-2  
 Bearings: page 12-1

All dimensions in mm  
 General tolerances  $\pm 0.13$  mm  
 Pressure angle  $20^\circ$   
 Material: Stainless steel 303

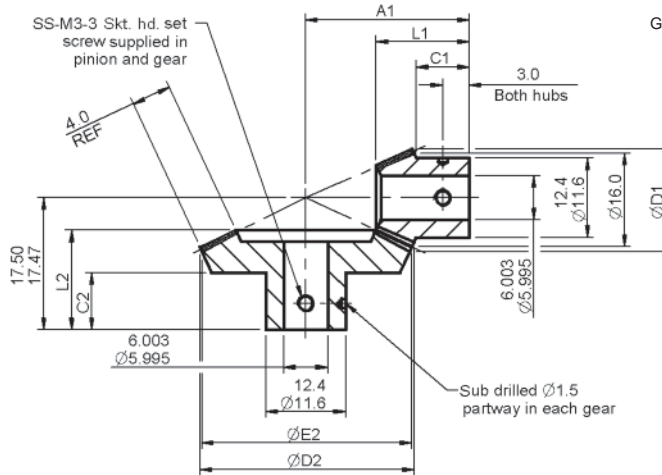

### Part number selection table

Gears supplied as a pair

| Part Number (pair) | Ratio | Module | Number of Teeth |      | Max. TTCE (pair) | Max. TCE (pair) |
|--------------------|-------|--------|-----------------|------|------------------|-----------------|
|                    |       |        | Pinion          | Gear |                  |                 |
| M05N-1S            | 1:1   | 0.5    | 32              | 32   | 0.025            | 0.050           |
| M05N-2S            | 2:1   |        | 32              | 64   |                  |                 |
| M05N-3S            | 3:1   |        | 32              | 96   |                  |                 |
| M05N-4S            | 4:1   |        | 32              | 128  |                  |                 |

### Dimension table

| Part Number (pair) | Overall Length $\pm 0.15$ |         | Outside Dia $+0.00 / -0.05$ |                   | Pitch Dia | Hub Length $\pm 0.25$ |           | Distance to Apex $+0.00 / -0.03$ |
|--------------------|---------------------------|---------|-----------------------------|-------------------|-----------|-----------------------|-----------|----------------------------------|
|                    | Pinion L1                 | Gear L2 | Pinion $\text{ØD1}$         | Gear $\text{ØD2}$ |           | Gear $\text{ØE2}$     | Pinion C1 | Gear C2                          |
| M05N-1S            | 12.52                     | 12.52   | 16.71                       | 16.71             | 16.0      | 7.50                  | 7.50      | 17.50                            |
| M05N-2S            | 11.80                     | 11.49   | 17.20                       | 32.29             | 32.0      | 7.00                  | 6.00      | 24.00                            |
| M05N-3S            | 9.98                      | 10.98   | 17.34                       | 48.19             | 48.0      | 5.30                  | 6.00      | 30.00                            |
| M05N-4S            | 10.03                     | 10.70   | 17.39                       | 64.14             | 64.0      | 5.50                  | 6.00      | 38.00                            |

### Features

- Gleason system
- Precision bevel gears supplied as a pair

### Technical support

- For modified or fully bespoke gears, please contact us
- Product overview - see page 5-2

Worms and Wheels



# 0.8 Module 8 mm Bore

# Precision Bevel Gears

All dimensions in mm  
General tolerances  $\pm 0.13$  mm  
Pressure angle  $20^\circ$   
Material: Stainless steel 303

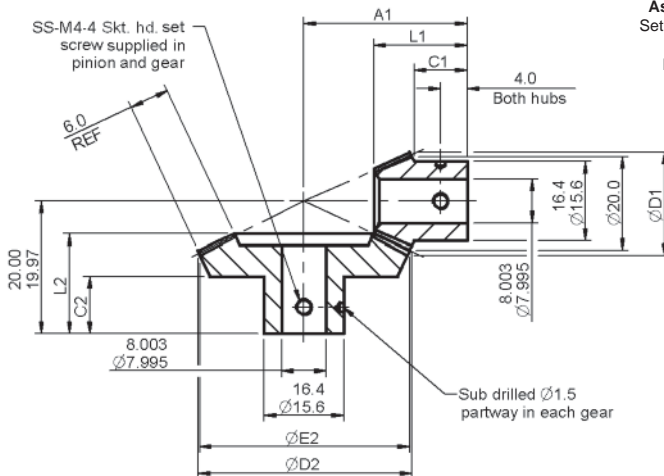

**Associated Products**  
Set screws: page 13-11  
Shafts: page 11-2  
Bearings: page 12-1

## Part number selection table

Gears supplied as a pair

| Part Number (pair) | Ratio | Module | Number of Teeth |      | Max. TTCE (pair) | Max. TCE (pair) |
|--------------------|-------|--------|-----------------|------|------------------|-----------------|
|                    |       |        | Pinion          | Gear |                  |                 |
| M08N-1S            | 1:1   | 0.8    | 25              | 25   | 0.025            | 0.050           |
| M08N-2S            | 2:1   |        | 25              | 50   |                  |                 |

## Dimension table

| Part Number (pair) | Overall Length $\pm 0.15$ |         | Outside Dia $+0.00 / -0.05$ |                | Pitch Dia      | Hub Lengths $\pm 0.25$ |         | Distance to Apex $+0.00 / -0.03$ |
|--------------------|---------------------------|---------|-----------------------------|----------------|----------------|------------------------|---------|----------------------------------|
|                    | Pinion L1                 | Gear L2 | Pinion $\phi D1$            | Gear $\phi D2$ | Gear $\phi E2$ | Pinion C1              | Gear C2 | Pinion A1                        |
| M08N-1S            | 14.51                     | 14.51   | 21.13                       | 21.13          | 20.0           | 8.30                   | 8.30    | 20.00                            |
| M08N-2S            | 15.70                     | 13.00   | 21.93                       | 40.47          | 40.0           | 9.00                   | 7.50    | 30.00                            |

Worms and  
Wheels

### Features

- Gleason system
- Precision bevel gears supplied as a pair

### Technical support

- For modified or fully bespoke gears, please contact us
- Product overview - see page 5-2

# Mitre Bevel Gears Integral Clamp

0.8, 1.0 & 1.5  
Module



**Associated Products**  
Set screws: page 13-11  
Shafts: page 11-2  
Bearings: page 12-1

All dimensions in mm  
Pressure angle 20°  
Material: Stainless steel SUS304

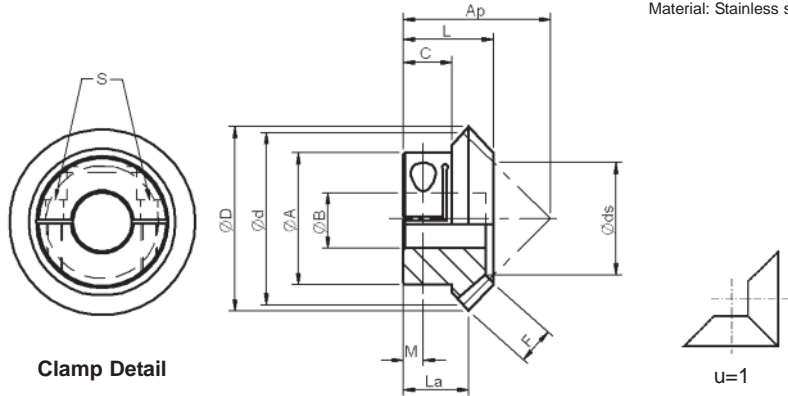

Gears supplied separately

## Part number selection table

Supplied with two clamp screws

| Part Number           | Ratio | Module | Number of Teeth | Face Width | Set Screw | M | Face Angle | Distance to Apex |
|-----------------------|-------|--------|-----------------|------------|-----------|---|------------|------------------|
|                       | u     |        |                 | F          | S         |   | Ap         |                  |
| <b>ML80SU20-1605</b>  | 1:1   | 0.8    | 20              | 3.7        | M2.5      | 3 | 49°3'      | 16.00            |
| <b>ML1SU20-2106</b>   |       | 1.0    | 20              | 4.3        | M3        | 4 | 49°3'      | 21.00            |
| <b>ML1SU30-2808</b>   |       | 1.0    | 30              | 6.2        | M4        | 5 | 47°42'     | 28.00            |
| <b>ML1.5SU20-3010</b> |       | 1.5    | 20              | 6.8        | M4        | 5 | 49°3'      | 30.00            |

## Dimension table

| Part Number           | Overall Length | Outside Dia | Pitch Dia | Bore Dia (H8) | Hub Dia | Hub Length | Tip Distance | Øds  |
|-----------------------|----------------|-------------|-----------|---------------|---------|------------|--------------|------|
|                       | L              | ØD          | Ød        | ØB            | ØA      | C          | La           |      |
| <b>ML80SU20-1605</b>  | 10.95          | 17.13       | 16        | 5             | 14.5    | 7.25       | 8.57         | 9.5  |
| <b>ML1SU20-2106</b>   | 14.48          | 21.41       | 20        | 6             | 16.0    | 9.00       | 11.71        | 11.8 |
| <b>ML1SU30-2808</b>   | 17.84          | 31.41       | 30        | 8             | 24.0    | 11.00      | 13.71        | 19.4 |
| <b>ML1.5SU20-3010</b> | 20.38          | 32.12       | 30        | 10            | 24.0    | 12.00      | 16.06        | 17.7 |

### **i** Features and options

- Gear quality: ISO 8
- Recommended shaft tolerance h7 or better
- Recommended shaft surface finish 1.6Ra or better
- Small quantities of selected items available ex-stock, please visit our on-line store [www.reliance.co.uk/shop](http://www.reliance.co.uk/shop)

### **?** Technical support

- Mitre bevel gears are not supplied as a pair and need to be ordered separately
- For allowable backlash - see [page T4-17](#)
- Product overview - see [page 5-2](#)

Worms and  
Wheels



# 0.8 & 1.0 Module

# Mitre Bevel Gears

All dimensions in mm  
Pressure angle 20°  
Material: Stainless steel SUS304

**Associated Products**  
Set screws: page 13-11  
Shafts: page 11-2  
Bearings: page 12-1

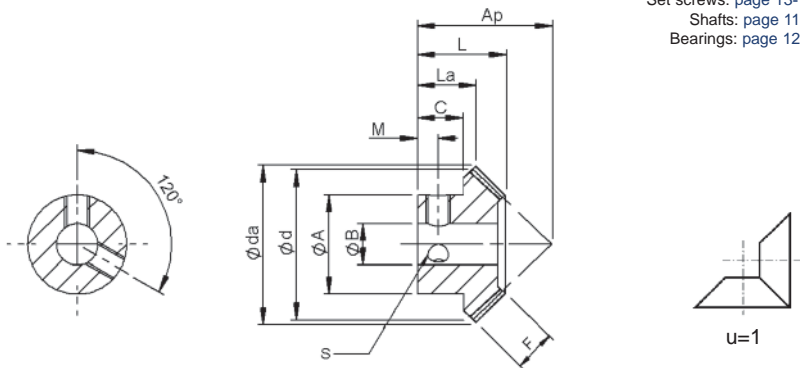

Gears supplied separately  
Set screw not supplied

## Part number selection table

| Part Number         | Ratio<br>u | Module | Number of Teeth | Face Width<br>F | Set Screw<br>S | M   | Face Angle | Distance to Apex<br>Ap |
|---------------------|------------|--------|-----------------|-----------------|----------------|-----|------------|------------------------|
| <b>M80SU20*1605</b> | 1:1        | 0.8    | 20              | 3.7             | M3             | 3.0 | 49°3'      | 16.00                  |
| <b>M80SU25*1805</b> |            | 0.8    | 25              | 4.7             | M3             | 3.0 | 48°51'     | 18.00                  |
| <b>M80SU30*2006</b> |            | 0.8    | 30              | 5.6             | M4             | 3.5 | 47°42'     | 20.00                  |
| <b>M1SU20*2106</b>  |            | 1.0    | 20              | 4.3             | M4             | 4.5 | 49°3'      | 21.00                  |
| <b>M1SU25*2306</b>  |            | 1.0    | 25              | 5.3             | M4             | 4.0 | 48°51'     | 23.00                  |
| <b>M1SU30*2608</b>  |            | 1.0    | 30              | 6.2             | M5             | 4.5 | 47°42'     | 26.00                  |

\* in part number denotes two threaded holes

## Dimension table

| Part Number         | Overall Length<br>L | Outside Dia<br>Øda | Pitch Dia<br>Ød | Bore Dia (H8)<br>ØB | Hub Dia<br>ØA | Hub Length<br>C | Tip Distance<br>La |
|---------------------|---------------------|--------------------|-----------------|---------------------|---------------|-----------------|--------------------|
| <b>M80SU20*1605</b> | 11.00               | 17.13              | 16.0            | 5                   | 12.0          | 6.00            | 8.57               |
| <b>M80SU25*1805</b> | 11.67               | 21.13              | 20.0            | 5                   | 16.0          | 6.00            | 8.57               |
| <b>M80SU30*2006</b> | 12.34               | 25.13              | 24.0            | 6                   | 18.0          | 6.00            | 8.57               |
| <b>M1SU20*2106</b>  | 14.53               | 21.41              | 20.0            | 6                   | 16.0          | 9.00            | 11.71              |
| <b>M1SU25*2306</b>  | 14.70               | 26.41              | 25.0            | 6                   | 20.0          | 8.00            | 11.21              |
| <b>M1SU30*2608</b>  | 15.89               | 31.41              | 30.0            | 8                   | 22.0          | 8.90            | 11.71              |

### **i** Features

- Gear quality: ISO 8
- Small quantities of selected items available ex-stock, please visit our on-line store [www.reliance.co.uk/shop](http://www.reliance.co.uk/shop)

### **?** Technical support

- Mitre bevel gears are not supplied as a pair and need to be ordered separately
- For allowable backlash - see [page T4-17](#)
- Product overview - see [page 5-2](#)



**Associated Products**  
 Set screws: page 13-11  
 Shafts: page 11-2  
 Bearings: page 12-1

All dimensions in mm  
 Pressure angle 20°  
 Material: Stainless steel SUS304

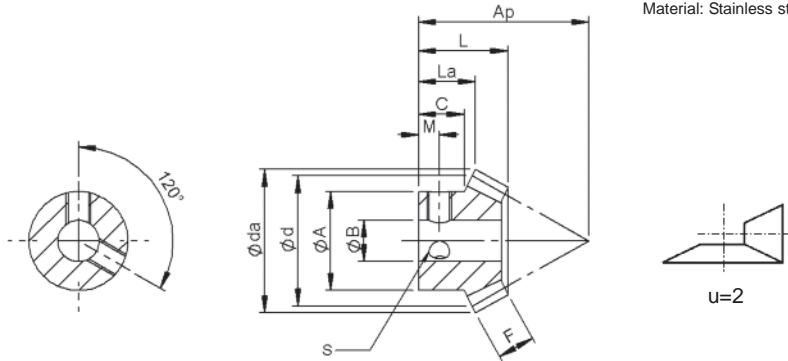

Gears supplied separately

Set screws not supplied

### Part number selection table

| Part Number      | Ratio<br>u | Module | Number of Teeth | Face Width<br>F | Set Screw |     | Face Angle | Distance to Apex<br>Ap |
|------------------|------------|--------|-----------------|-----------------|-----------|-----|------------|------------------------|
|                  |            |        |                 |                 | S         | M   |            |                        |
| <b>B80SU20*5</b> | 2:1        | 0.8    | 20              | 4.5             | M3        | 2.5 | 29°8'      | 22.50                  |
| <b>B80SU40*6</b> |            | 0.8    | 40              | 4.5             | M4        | 3.5 | 66°0'      | 16.46                  |
| <b>B1SU20*6</b>  |            | 1.0    | 20              | 5.7             | M4        | 4.0 | 29°8'      | 29.60                  |
| <b>B1SU40*8</b>  |            | 1.0    | 40              | 5.7             | M5        | 4.0 | 66°0'      | 21.80                  |

\* in part number denotes two threaded holes

### Dimension table

| Part Number      | Overall Length | Outside Dia | Pitch Dia | Bore Dia (H8) | Hub Dia | Hub Length | Tip Distance |
|------------------|----------------|-------------|-----------|---------------|---------|------------|--------------|
|                  | L              | Øda         | Ød        | ØB            | ØA      | C          | La           |
| <b>B80SU20*5</b> | 10.79          | 17.43       | 16.0      | 5             | 12.0    | 5.5        | 6.86         |
| <b>B80SU40*6</b> | 11.01          | 32.72       | 32.0      | 6             | 20.0    | 6.0        | 9.18         |
| <b>B1SU20*6</b>  | 15.03          | 21.79       | 20.0      | 6             | 16.0    | 8.6        | 10.05        |
| <b>B1SU40*8</b>  | 15.02          | 40.89       | 40.0      | 8             | 25.0    | 8.0        | 12.69        |

### **i** Features

- Gear quality: ISO 8
- Small quantities of selected items available ex-stock, please visit our on-line store [www.reliance.co.uk/shop](http://www.reliance.co.uk/shop)

### **?** Technical support

- Mitre bevel gears are not supplied as a pair and need to be ordered separately
- For allowable backlash - see [page T4-17](#)
- Product overview - see [page 5-2](#)

Worms and  
Wheels



# 0.5, 0.8 & 1.0 Module

# Brass Bevel Gears

All dimensions in mm

Pressure angle 20°

Material: Brass ISO CuZn39Pb3

Associated Products

Shafts: page 11-2

Bearings: page 12-1

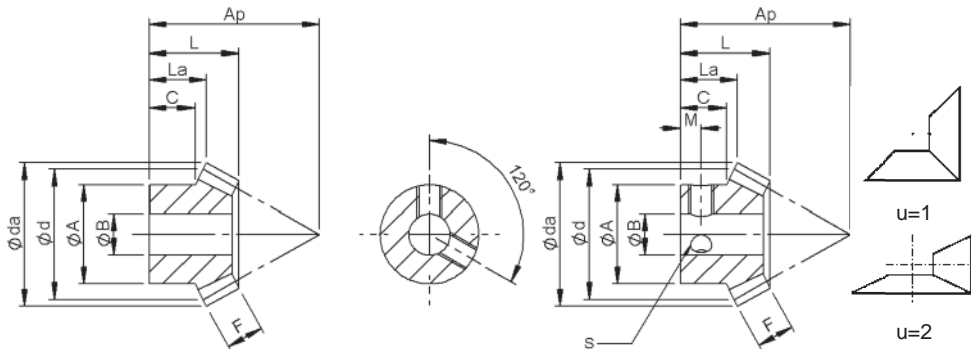

Gears supplied separately

Set screw supplied

## Part number selection table

| Part Number        | Ratio<br>u | Module | Number of<br>Teeth | Face<br>Width<br>F | Face<br>Angle | Distance<br>to Apex<br>Ap |
|--------------------|------------|--------|--------------------|--------------------|---------------|---------------------------|
| <b>M50B20-1103</b> | 1:1        | 0.5    | 20                 | 2.5                | 49°3'         | 11.00                     |
| <b>B50B20</b>      | 2:1        | 0.5    | 20                 | 3.2                | 29°8'         | 15.52                     |
| <b>B50B40</b>      | 2:1        | 0.5    | 40                 | 3.2                | 66°0'         | 10.56                     |
| <b>M80B20-1605</b> | 1:1        | 0.8    | 20                 | 3.7                | 49°3'         | 16.00                     |
| <b>B80B20</b>      | 2:1        | 0.8    | 20                 | 4.5                | 29°8'         | 22.50                     |
| <b>B80B40</b>      | 2:1        | 0.8    | 40                 | 4.5                | 66°0'         | 16.46                     |
| <b>M1B20*2106</b>  | 1:1        | 1.0    | 20                 | 4.3                | 49°3'         | 21.00                     |

\* in part number denotes two threaded holes

## Dimension table

| Part Number        | Overall Length<br>L | Outside Dia<br>Øda | Pitch Dia<br>Ød | Bore Dia (H8)<br>ØB | Hub Dia<br>ØA | Hub Length<br>C | Tip Distance<br>La | Hole Detail |     |
|--------------------|---------------------|--------------------|-----------------|---------------------|---------------|-----------------|--------------------|-------------|-----|
|                    |                     |                    |                 |                     |               |                 |                    | S           | M   |
| <b>M50B20-1103</b> | 8.00                | 10.71              | 10.0            | 3                   | 8             | 5.0             | 6.35               | -           | -   |
| <b>B50B20</b>      | 8.54                | 10.89              | 10.0            | 3                   | 8             | 5.0             | 5.74               | -           | -   |
| <b>B50B40</b>      | 7.31                | 20.45              | 20.0            | 4                   | 12            | 4.0             | 6.01               | -           | -   |
| <b>M80B20-1605</b> | 11.00               | 17.13              | 16.0            | 5                   | 12            | 6.0             | 8.57               | -           | -   |
| <b>B80B20</b>      | 10.79               | 17.43              | 16.0            | 5                   | 12            | 5.5             | 6.86               | -           | -   |
| <b>B80B40</b>      | 11.01               | 32.72              | 32.0            | 6                   | 20            | 6.0             | 9.18               | -           | -   |
| <b>M1B20*2106</b>  | 14.53               | 21.41              | 20.0            | 6                   | 16            | 9.0             | 11.71              | M4          | 4.5 |

### **i** Features

- Gear quality: ISO 8
- Small quantities of selected items available ex-stock, please visit our on-line store [www.reliance.co.uk/shop](http://www.reliance.co.uk/shop)

### **?** Technical support

- Bevel gears are not supplied as a pair and need to be ordered separately
- For allowable backlash - see [page T4-17](#)
- Product overview - see [page 5-2](#)



**Associated Products**  
Spur gears: from page 4-36

All dimensions in mm  
Pressure angle 20°  
Material: Brass ISO CuZn38Pb2,  
CuZn39Pb3

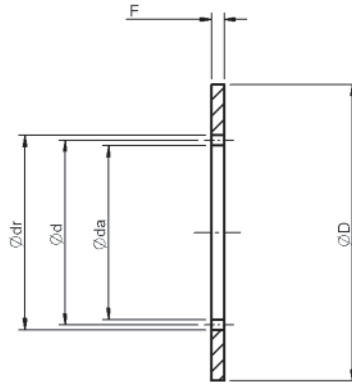

### Part number selection table

| Part Number    | Module | Number of Teeth | PCD<br>Ød | Gear O/D<br>Øda | Root Dia<br>Ødr | Face Width<br>F | Ring O/D<br>ØD |
|----------------|--------|-----------------|-----------|-----------------|-----------------|-----------------|----------------|
| IS50B60A-0350  | 0.5    | 60              | 30.0      | 29.0            | 31.25           | 3               | 50             |
| IS50B80A-0360  |        | 80              | 40.0      | 39.0            | 41.25           |                 | 60             |
| IS50B90A-0370  |        | 90              | 45.0      | 44.0            | 46.25           |                 | 70             |
| IS50B100A-0375 |        | 100             | 50.0      | 49.0            | 51.25           |                 | 75             |
| IS50B120A-0380 |        | 120             | 60.0      | 59.0            | 61.25           |                 | 80             |



### **i** Features and options

- 0.8 module and 1.0 module available
- Designed to fit housings with bore tolerance H8
- 1.0 module also available in carbon steel ISO C45, please contact us
- Small quantities of selected items available ex-stock, please visit our on-line store [www.reliance.co.uk/shop](http://www.reliance.co.uk/shop)





# Section Contents

Racks and Pinions - Overview .....Page 6-2

Precision Ground Rack - Hardened Rectangular .....Page 6-3

Precision Ground Rack - Hardened Round .....Page 6-4

Precision Ground Rack - Soft Round Solid .....Page 6-5

Precision Ground Rack - Soft Round Tubular .....Page 6-6

Precision Hobbed Rack - Soft Round.....Page 6-7

Precision Hobbed Rack - Soft Rectangular .....Page 6-8

Hobbed Brass Rack - Rectangular .....Page 6-9

Plain Rack Pinions .....Page 6-10

Hardened Rack Pinions .....Page 6-10

Anti-backlash Rack Pinions .....Page 6-11

Technical Information.....Page T6-1

# Round and Rectangular Racks and Pinions



## Accurate conversion from rotary to linear motion

A rack and pinion system gives the ability to transfer rotary to linear motion, with all the accuracy expected of a geared system.



The racks are manufactured from ground, hardened stainless steel or ground stainless steel and available with a choice of accuracies, pitches, and lengths, plus the facility to provide modifications such as flats, journals or custom ends. Hobbed stainless steel and brass racks are also available. The rack pinions are plain or anti-backlash, also with a choice of accuracies, pitches, bore sizes, alternative materials and coatings.

Ground racks can be used for both measurement and actuation. In general the smaller pitches (1 mm) suit measurement as the smaller pinion diameter gives higher linear resolutions. The larger pitches (2 mm and 2.5 mm) allow for a higher load capacity. For most applications the rack can be used for both the feedback and the actuation; however in very precise applications it is best to use a non-drive section of the rack for feedback, alternatively a separate rack can be used. Hobbed racks are more suited to light actuation applications where cost is a key consideration.

We offer three types of rack – rectangular racks, solid round racks and tubular racks. Rectangular racks are used when the application requires the rack to be stationary and the rack pinion provides the element of motion. Our rectangular racks are used with a motor, slide and carriage for example in the printing industry for the actuation of paper cutting knives in a printing press. Round racks are a more flexible alternative, with regard to mounting, used for example in XY stages. The tubular racks allow for the passage of fluids, fibre-optics, gasses etc, making them ideal for medical and scientific applications, such as laboratory automation pick and place mechanisms.

For a fully integrated solution the Racktuator™ (see [page 2-14](#)) is a combined rack and intelligent motor actuation system. Bringing together Reliance’s racks and Cool Muscle servo system, the Racktuator™ provides a very high level of control and accuracy in a compact, space saving package.



Laboratory automation systems



Printing automation systems

# Precision Ground Rack Hardened Rectangular

1, 2 & 2.5mm  
Circular Pitch



**Associated Products**  
Rack pinions: page 6-10

All dimensions in mm  
Material: Stainless steel grade 416  
Treatment: Hardened to 35-45 HRC  
Pressure angle 20°

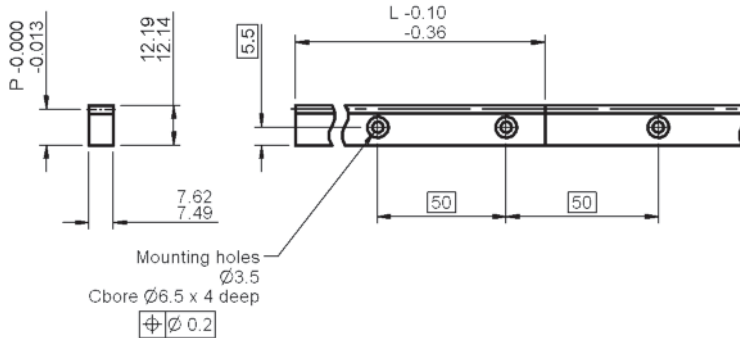

## Part number selection table

| Part Number | Circular Pitch (mm) | Length L | Pitch Height P | Number of Holes |
|-------------|---------------------|----------|----------------|-----------------|
| R9-1M-300   | 1                   | 300      | 11.869         | 6               |
| R9-2M-300   | 2                   |          | 11.550         |                 |
| R9-25M-300  | 2.5                 |          | 11.391         |                 |



### **i** Features and options

- Cumulative pitch error less than 0.008 mm per 300 mm
- Ground teeth, accuracy grade 4 as standard
- Alternative grades available - see [page T6-1](#)
- Unlimited axis lengths possible by setting individual racks together
- Shorter lengths available
- Alternative pitches, including module
- Small quantities of selected items available ex-stock, please visit our on-line store: [www.reliance.co.uk/shop](http://www.reliance.co.uk/shop)

### **?** Technical support

- Installation information - see [page T6-4](#)
- Technical information - see [pages T6-1 to T6-6](#)
- PTFE based grease is recommended for lubrication
- For modified or fully bespoke racks, please contact us



# Ø12mm 2mm Circular Pitch

# Precision Ground Rack Hardened Round

All dimensions in mm  
 General tolerances  $\pm 0.13$  mm  
 Material: Linear bearing shaft  
 stainless steel grade 440C  
 or X90CrMoV18  
 Treatment: Case hardened to  
 55 HRC min  
 Pressure angle 20°

**Associated Products**  
 Rack pinions: page 6-10

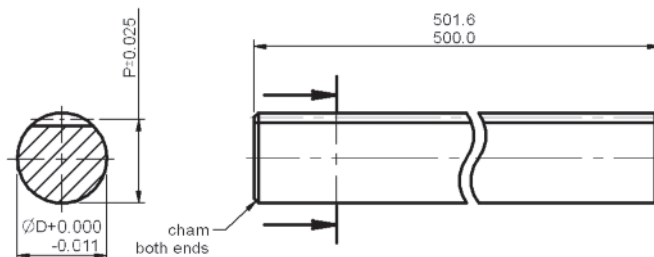

## Part number selection table

| Part Number | Circular Pitch (mm) | Outer Dia ØD | Pitch Height P | Rack Thrust (N) |
|-------------|---------------------|--------------|----------------|-----------------|
| RR12-1M-500 | 1                   | 12           | 11.841         | 30*             |
| RR12-2M-500 | 2                   |              | 11.682         | 60*             |

\* Rack thrust based on meshing with a 60 tooth hardened rack pinion, theoretically calculated.



### **i** Features and options

- Cumulative pitch error less than 0.025 mm
- Ground teeth, accuracy grade 3 as standard
- Higher accuracy grades available
- Bearing surface and drive in one component
- Shorter lengths available
- Alternative pitches available
- Flats, journals and end modifications
- Small quantities of selected items available ex-stock, please visit our on-line store: [www.reliance.co.uk/shop](http://www.reliance.co.uk/shop)

### **?** Technical support

- Installation information - see [page T6-4](#)
- Technical information - see [pages T6-1 to T6-6](#)
- PTFE based grease is recommended for lubrication
- Can be used with both open and closed linear bearings with either 4, 5 or 6 ball tracks (the bearing must be positioned so the balls do not run on the edges of the teeth - see [page T6-3](#)).
- For modified or fully bespoke racks, please contact us



### Associated Products

Rack pinions - CP: page 6-10

Rack pinions - Module: page 4-12

All dimensions in mm  
General tolerances  $\pm 0.13$  mm  
Material: Stainless steel grade 300  
Pressure angle 20°

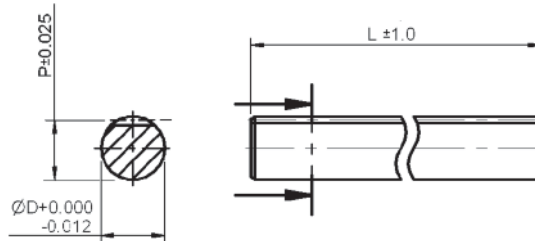

## Part number selection table

| Part Number          | Pitch (mm) | Length L | Outer Dia $\text{Ø}D$ | Bore Dia $\text{Ø}d$ | Pitch Height P | Rack Thrust (N) |
|----------------------|------------|----------|-----------------------|----------------------|----------------|-----------------|
| <b>RRS06-1M-500</b>  | 1 mm CP    | 500      | 6                     | -                    | 5.682          | 20*             |
| <b>RRS10-050-500</b> | 0.5 module |          | 10                    | -                    | 9.500          | 40*             |

\* Rack thrust based on meshing with a 50 tooth stainless steel pinion, 3 N if used with a 50 tooth PEEK polymer pinion.



### **i** Features and options

- Cumulative pitch error less than 0.050 mm
- Ground teeth, accuracy grade 2 as standard
- High resistance to pitting corrosion
- Flats, journals and end modifications
- Ideal for medical and scientific applications
- Bearing surface and drive in one component
- Shorter lengths available
- Alternative pitches available
- Small quantities of selected items available ex-stock, please visit our on-line store: [www.reliance.co.uk/shop](http://www.reliance.co.uk/shop)

### **?** Technical support

- Installation information - see [page T6-4](#)
- Technical information - see [pages T6-1 to T6-6](#)
- PTFE based grease is recommended for lubrication
- For modified or fully bespoke racks, please contact us



# 1mm Circular Pitch 0.3 Module

# Precision Ground Rack Soft Round Tubular

All dimensions in mm  
General tolerances  $\pm 0.13$  mm  
Material: Stainless steel grade 316  
Pressure angle  $20^\circ$

**Associated Products**  
Rack pinions - CP: page 6-10  
Rack pinions - Module: page 4-12

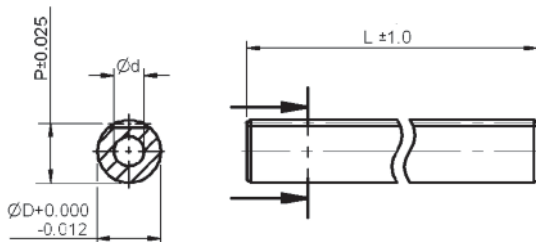

## Part number selection table

| Part Number          | Pitch (mm) | Length L | Outer Dia $\varnothing D$ | Bore Dia $\varnothing d$ | Pitch Height P | Rack Thrust (N) |
|----------------------|------------|----------|---------------------------|--------------------------|----------------|-----------------|
| <b>RRT06-1M-500</b>  | 1 mm CP    | 500      | 6                         | 3.6                      | 5.682          | 20*             |
| <b>RRT06-030-500</b> | 0.3 module |          |                           |                          | 5.700          |                 |

\* Rack thrust based on meshing with a 50 tooth stainless steel pinion, 3 N if used with a 50 tooth PEEK polymer pinion.



### **i** Features and options

- Cumulative pitch error less than 0.050 mm
- Ground teeth, accuracy grade 2 as standard
- High resistance to pitting corrosion
- Hollow shaft allows for the passage of fluids, fibre-optics and gasses etc
- Ideal for medical and scientific applications
- Bearing surface and drive in one component
- Flats, journals and end modifications
- Shorter lengths available
- Alternative pitches available
- Small quantities of selected items available ex-stock, please visit our on-line store: [www.reliance.co.uk/shop](http://www.reliance.co.uk/shop)

### **?** Technical support

- Installation information - see [page T6-4](#)
- Technical information - see [pages T6-1 to T6-6](#)
- PTFE based grease is recommended for lubrication
- For modified or fully bespoke racks, please contact us

# Precision Hobbed Rack Soft Round

0.5, 0.75, 0.8  
& 1.0 Module



Associated Products  
Rack pinions: page 4-12

All dimensions in mm  
Material: Stainless steel grade 304  
Pressure angle 20°

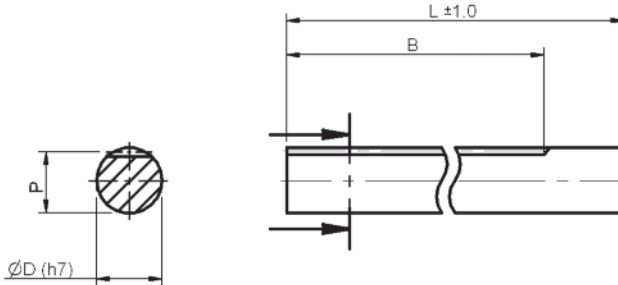

## Part number selection table

| Part Number   | Module | Number of Teeth | Length L | Pitch Height P | Extent of Teeth B | Diameter D | Weight (g) |
|---------------|--------|-----------------|----------|----------------|-------------------|------------|------------|
| ORK50SU2-0815 | 0.5    | 95              | 202      | 7.5            | 149               | 8          | 78         |
| ORK75SU2-0815 | 0.75   | 63              | 202      | 7.25           | 148               | 8          | 76         |
| ORK80SU2-0815 | 0.8    | 59              | 202      | 7.2            | 148               | 8          | 76         |
| ORK1SU3-1024  | 1.0    | 76              | 305      | 9.0            | 238               | 10         | 177        |



### **i** Features and options

- Longer tooth lengths available, please contact us
- Small quantities of selected items available ex-stock, please visit our on-line store: [www.reliance.co.uk/shop](http://www.reliance.co.uk/shop)

### **?** Technical support

- PTFE based grease is recommended for lubrication
- Installation information - see [page T6-4](#)
- Technical information - see [pages T6-1 to T6-6](#)
- For modified or fully bespoke racks, please contact us



# 0.5, 0.75, 0.8 & 1.0 Module

# Precision Hobbed Rack Soft Rectangular

All dimensions in mm  
Material: Stainless steel grade 304  
Pressure angle 20°

**Associated Products**  
Rack pinions: page 4-12

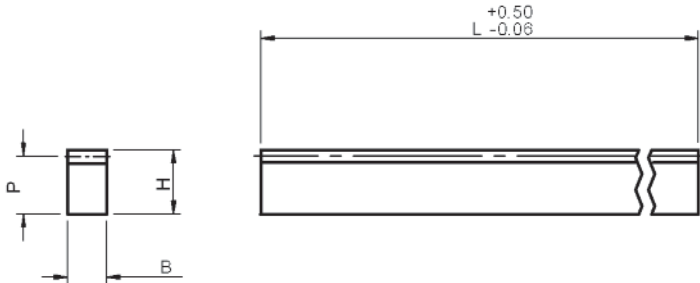

## Part number selection table

| Part Number         | Module | Number of Teeth | Length L | Pitch Height P | Face width B (h12) | Height H (h12) | Weight (g) |
|---------------------|--------|-----------------|----------|----------------|--------------------|----------------|------------|
| <b>RK50SU2-0310</b> | 0.5    | 126             | 202~205  | 9.5            | 3                  | 10             | 45         |
| <b>RK50SU2-0808</b> |        |                 |          | 7.5            | 8                  | 8              | 95         |
| <b>RK75SU2-0310</b> | 0.75   | 83              | 202~205  | 9.25           | 3                  | 10             | 44         |
| <b>RK75SU2-0808</b> |        |                 |          | 7.25           | 8                  | 8              | 91         |
| <b>RK80SU5-0510</b> | 0.8    | 198             | 505~508  | 9.2            | 5                  | 10             | 183        |
| <b>RK1SU5-0810</b>  | 1.0    | 158             | 505~508  | 9              | 8                  | 10             | 280        |



### **i** Features and options

- Racks are manufactured from cold drawn stainless steel
- Small quantities of selected items available ex-stock, please visit our on-line store: [www.reliance.co.uk/shop](http://www.reliance.co.uk/shop)

### **?** Technical support

- PTFE based grease is recommended for lubrication
- Installation information - see [page T6-4](#)
- Technical information - see [pages T6-1 to T6-6](#)
- For modified or fully bespoke racks, please contact us



# Hobbed Brass Rack Rectangular

0.3, 0.5, 0.75  
& 0.8 Module



Associated Products  
Rack pinions: page 4-12

All dimensions in mm  
Material: Brass grade CuZn39Pb3  
Pressure angle 20°

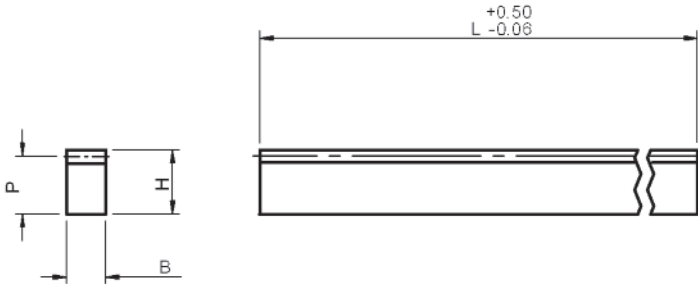

## Part number selection table

| Part Number        | Module | Number of Teeth | Length L | Pitch Height P | Face width B (h11) | Height H (h11) | Weight (g) |
|--------------------|--------|-----------------|----------|----------------|--------------------|----------------|------------|
| <b>RK30B2-0308</b> | 0.3    | 210             | 200      | 7.7            | 3                  | 8              | 38         |
| <b>RK50B2-0808</b> | 0.5    | 125             | 200      | 7.5            | 8                  | 8              | 98         |
| <b>RK75B2-0808</b> | 0.75   | 82              | 200      | 7.25           | 8                  | 8              | 95         |
| <b>RK80B5-0510</b> | 0.8    | 198             | 505      | 9.2            | 5                  | 10             | 191        |



### **i** Features and options

- Brass racks, ideal for lightly loaded applications, an economic balance of accuracy and load capacity against cost
- Manufactured from cold drawn material
- Small quantities of selected items available ex-stock, please visit our on-line store: [www.reliance.co.uk/shop](http://www.reliance.co.uk/shop)

### **?** Technical support

- Installation information - see page T6-4
- Technical information - see pages T6-1 to T6-6
- For modified or fully bespoke racks, please contact us



# 6 mm & 10 mm Bore

# Plain and Hardened Rack Pinions

All dimensions in mm  
 General tolerances  $\pm 0.13$  mm  
 Material: Hardened pinions - 17-4 PH, 35-42HRc  
 Plain pinions - Stainless steel 316  
 Pressure angle 20°

**Associated Products**  
 Racks: page 6-3

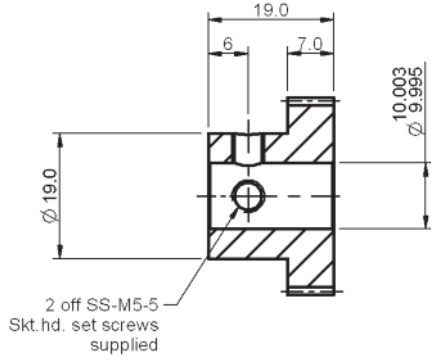
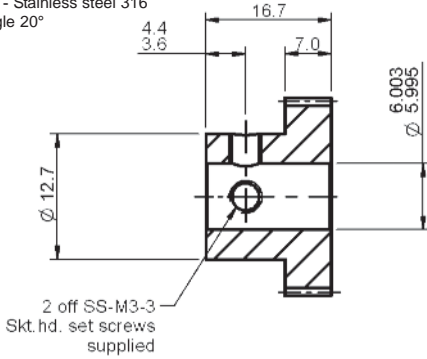

## Part number selection table

Example Part No:- SH25MS2B6F7A- 32

| Basic Part Number |                | Circular Pitch (mm) | Bore Size | Number of Teeth |     |
|-------------------|----------------|---------------------|-----------|-----------------|-----|
| Plain             | Hardened       |                     |           | Min             | Max |
| SH1MS2B6F7A-      | SH1MS8B6F7A-   | 1                   | 6         | 43              | 111 |
| SH2MS2B6F7A-      | SH2MS8B6F7A-   | 2                   |           | 23              | 54  |
| SH25MS2B6F7A-     | SH25MS8B6F7A-  | 2.5                 |           | 19              | 43  |
| SH1MS2B10F7A-     | SH1MS8B10F7A-  | 1                   | 10        | 63              | 104 |
| SH2MS2B10F7A-     | SH2MS8B10F7A-  | 2                   |           | 33              | 51  |
| SH25MS2B10F7A-    | SH25MS8B10F7A- | 2.5                 |           | 27              | 40  |

### **i** Features and options

- Standard accuracy AQ10 - see page T4-1
- Hardened pinions provide longer pinion life, higher load capacity and higher thrust
- Higher accuracies available
- Alternative pitches available
- Alternative bore sizes, including imperial available
- Alternative materials available
- Special wear resistant coating available
- For modified or fully bespoke pinions, please contact us





Associated Products  
Racks: page 6-3

All dimensions in mm  
General tolerances  $\pm 0.13$  mm  
Pressure angle 20°  
Material: Stainless steel 316

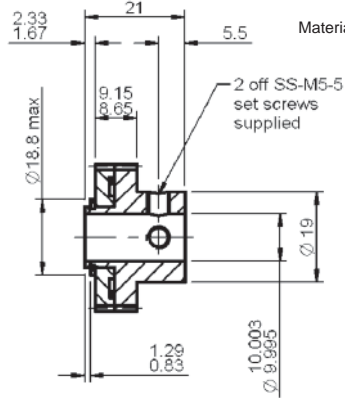
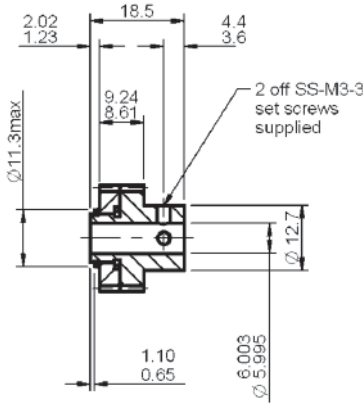

### Part number selection table

Example Part No:- AH25MS2B6F89A- 20

| Basic Part Number | Circular Pitch (mm) | Bore Size | Number of Teeth |     |
|-------------------|---------------------|-----------|-----------------|-----|
|                   |                     |           | Min             | Max |
| AH1MS2B6F89A-     | 1                   | 6         | 46              | 54  |
| AH2MS2B6F89A-     | 2                   |           | 24              | 26  |
| AH25MS2B6F89A-    | 2.5                 |           | 20              | 20  |
| AH1MS2B10F89A-    | 1                   | 10        | 87              | 104 |
| AH2MS2B10F89A-    | 2                   |           | 45              | 51  |
| AH25MS2B10F89A-   | 2.5                 |           | 37              | 40  |

### **i** Features and options

- Standard accuracy AQ10 - see page T4-1
- Higher accuracies available
- Ideal for use with Reliance soft and hardened, round and rectangular racks
- Ideal for lightly loaded measurement applications
- Alternative pitches available
- Alternative bore sizes, including imperial available
- Alternative materials available
- Special wear resistant coating available
- For modified or fully bespoke pinions, please contact us





# Section Contents

## Leadscrew and Nut Assemblies

- Product Overview .....Page 7-2
- Selection Guide .....Page 7-6
- Leadscrew Sizes .....Page 7-7
- Leadscrew Nuts .....Page 7-12
- Modified and Custom Nuts .....Page 7-26
- Leadscrew End Modifications .....Page 7-27
- Custom Leadscrew End Modifications .....Page 7-34

## Leadscrew Assemblies

- Product Overview .....Page 7-36
- Leadscrew Linear Slide - RGLS .....Page 7-38
- ScrewRail® Actuator Assembly - RSRA .....Page 7-40
- Anti-backlash ScrewRail® Actuator Assembly - RSRZ.....Page 7-42

Technical Information.....Page T7-1



## Precise, efficient linear motion

Reliance's leadscrew and nut assemblies provide a flexible, integrated solution for linear motion. Available in a wide choice of leadscrew sizes and nut styles, with options for custom designed nuts and leadscrew end modifications, the range offers the flexibility to address a wide variety of requirements.



Leadscrews are provided with leads from 0.3 mm to 92 mm, screw diameters from 3 mm to 19 mm and thread lengths of up to 4 metres, making them an effective solution, even for high linear speed applications. They are available in a range of materials and coatings, with a choice of cut or standard interfacing ends, or with the option of custom machined ends. The screw thread form has been specifically designed for long life and quiet operation. It is manufactured using a rolled process, a highly consistent method of production resulting in a cost-effective, quality product.

The leadscrew and nut assemblies have been designed specifically for motion control applications, rather than using adaptations of general purpose screws and nuts. There are 11 different leadscrew nut styles, with a choice of mounts and also options for custom-designed nuts. The leadscrew nuts are made from moulded plastic, which enables custom nuts to be produced with features of the drive system, such as bushings, carriages, pulleys and gears, integrated within the nut. This type of custom, multi-functional nut can offer a significant reduction in part count, reducing cost and assembly time in the overall mechanism.

The polyacetal nuts have a lubricating additive to provide longer life which, when combined with low friction leadscrew coatings, can extend the life of a standard leadscrew assembly by up to 300%. The assemblies are self-lubricating, making them ideally suited to medical and laboratory applications.

With lead accuracies up to 0.0001 mm/mm and positional bi-directional repeatability within 1.5 micron (0.0015 mm) on anti-backlash designs, the leadscrew and nut assemblies are ideal for applications requiring precise, efficient linear motion.



Micro dispensing syringe drives

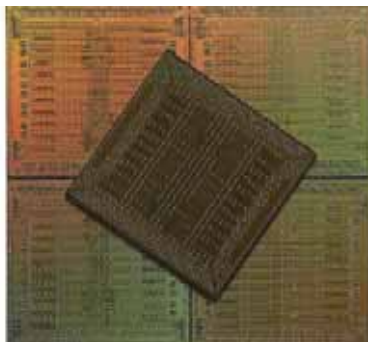

Semiconductor microchip production



### Part number structure

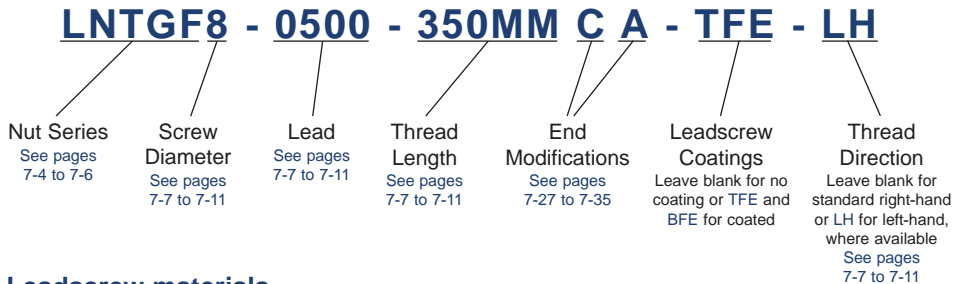

### Leadscrew materials

Leadscrews are rolled from a premium grade, corrosion resistant and non-magnetic 303 stainless steel. Other materials are available including 316 and 400 series stainless steel, precipitation hardened steels, aluminium and titanium. These materials are ideally suited for industries such as medical, vacuum, cleanroom, food and human contact, salt spray and cryogenics.

### Leadscrew coatings

Standard leadscrew nuts are manufactured from self-lubricating plastics. We also offer soft TFE and hard BFE low friction coatings for the leadscrew; lubrication to the screw/nut interface occurs by the nut picking up TFE particles from the coating as well as from migration of the internal lubricant from within the plastic nut.

We also supply leadscrews with specialist nickel/TFE coatings and offer a choice of coatings used in medium vacuum applications (up to  $10^{-6}$ ). Alternatively a BFE coating can be provided. This is a special proprietary hard coating which shares many of the benefits of TFE coating but offers exceptional durability in more aggressive environments and where reduced friction and a permanent coating is desired.

Although care should be taken to ensure that chips and voids do not occur in the coating, small voids have been shown to have little effect on the system performance. The lubricant, although solid, has some of the "spreading" ability of fluid lubricants. When machining bearing ends, soft fixtures are recommended to protect the coating.

TFE coated screws provide the maximum level of self-lubrication and should not be additionally lubricated or used in environments where oils or other lubricant contamination is possible.

Coatings, available for only a small additional cost, give the best results on wear life, coefficient of friction and torque to drive the leadscrew assembly. To select a coating add -TFE or -BFE to the part number shown above.

### Leadscrew ends

Leadscrews are provided with the options of cut ends or a range of standard end modifications suitable for interfacing with ball bearings, circlips, couplings, pulleys and gears. Alternatively custom end modifications can be supported. See [pages 7-27 to 7-35](#).



**LBF MINI series** - Miniature nut for applications that do not require anti-backlash or wear compensation.



**LPX series** - Long life for applications that do not require anti-backlash or wear compensation.



**LNTG series** - Adjustable drag, compact design, anti-backlash nut assembly allows drag torque to be pre-set according to system requirements.



**LAB series** - Incorporates a lockable, adjustable sleeve to set the drag torque of the nut and to provide manual backlash control.



**LNTB MINI series** - Miniature anti-backlash nut for applications requiring axial stiffness through life with minimal drag torque.



**LNTB series** - Flexible design, self-compensating anti-backlash nut assembly maintains axial stiffness throughout its life with minimum system drag torque.



**LAF series** - Light loads. Precise position accuracy and repeatability. Anti-backlash.



**LAK series** - Moderate loads. Delivers increased load capacity and greater axial stiffness with low drag torque. Anti-backlash.



**LWD series** - Moderate loads. An anti-backlash, self-lubricating acetal nut. Compact design provides stiffness and accuracy for precise positioning.



**LCM series** - Light loads, compact design. Anti-backlash.



**LAX series** - Heavy loads. Delivers maximum load carrying capacity with highest axial and radial stiffness. Anti-backlash.



**Custom Design** - Specials to suit your application.





### Alternative nut styles

Reliance offers a wide variety of standard nut designs and the matrix below is intended as a general guide to help select the most appropriate nut for the application. More detailed technical data is provided on pages 7-12 to 7-25.

|                          |                |
|--------------------------|----------------|
| Comparative star rating: |                |
| ●●●                      | best           |
| ●                        | good           |
| ☒                        | not applicable |

### Nut feature matrix

| Nut Feature                                      | Nut Style |     |      |     |      |     |     |     |     |     |
|--|-----------|-----|------|-----|------|-----|-----|-----|-----|-----|
|  | LBF       | LPX | LNTG | LAB | LNTB | LAF | LAK | LWD | LCM | LAX |
| Compactness                                      | ●●●       | ●●● | ●●●  | ●●  | ●●   | ●●  | ●●  | ●●● | ●●● | ●   |
| Dynamic load capability                          | ●●●       | ●●● | ●●   | ●●  | ●●   | ●   | ●●  | ●●  | ●●  | ●●● |
| Minimal drag torque                              | ☒         | ☒   | ●●   | ●●  | ●●   | ●●  | ●●● | ●●  | ●   | ●●● |
| Vibration damping (horizontal)                   | ☒         | ☒   | ●●   | ●●● | ●    | ●●● | ●●  | ●   | ●   | ●●  |
| Vibration damping (vertical)                     | ☒         | ☒   | ●    | ●●● | ●    | ●●● | ●   | ●   | ●   | ●   |
| Smoothness of operation (printing/scanning)      | ●         | ●   | ●●●  | ●●● | ●●   | ●●  | ●●  | ●●  | ●   | ●●  |
| Backlash/wear compensation capability            | ☒         | ☒   | ●    | ●   | ●●●  | ●●  | ●●● | ●●● | ●●● | ●●● |
| Ease of user adjustment of drag torque/backlash  | ☒         | ☒   | ●●●  | ●●● | ●    | ☒   | ●●  | ☒   | ☒   | ●●  |
| Stiffness (less axial bi-directional compliance) | ☒         | ☒   | ●●   | ●●  | ●●●  | ●●  | ●●● | ●●● | ●●● | ●●● |
| Ability to add modifications                     | ●●●       | ●●● | ●    | ●   | ●●●  | ●●  | ●   | ●   | ●   | ●   |
| Ability to manufacture with custom material      | ●●●       | ●●● | ●●   | ●●  | ●●●  | ●●  | ●   | ●   | ●   | ●   |
| Ability to work with finer leads <5.08 mm        | ●●●       | ●●● | ●●●  | ●●● | ●●   | ●●● | ●●● | ●●● | ●●● | ●●● |
| Ability to work with long leads >25.4 mm         | ●●●       | ●●● | ●    | ●●● | ●●●  | ●●● | ●●● | ●●● | ●●● | ●●● |

### Nut mounting options

The nuts are available in several different designs including anti-backlash, adjustable anti-backlash, general purpose and miniature. Most nuts are available with a triangular, round or threaded mount. Custom requirements can be supported using specialist mould designs, see [page 7-26](#)

### Modified and custom nuts

All of the nuts can be modified to some degree to help tailor them to specific requirements, alternatively fully customised nuts can be supplied, see [page 7-26](#).

### Nut materials

Due to the controlled manufacturing processes, we can offer nuts in different types of plastics that can be moulded, e.g. PEEK, special carbon or other fibre filled plastics. Even though the standard design and materials developed for the leadscrew nut assemblies are commonly plastics, metal nuts made from bronze, brass or aluminium alloy can also be supplied. For the optimum technical and cost effective solution, we are able to supply special moulded nuts impregnated with carbon fibre for strength, or nuts over-moulded on metal to help minimise the number of components in the assembly.



| Nominal Screw Diameter | Property                    | LBF <sup>1</sup> LPX <sup>2</sup> Series | LNTG Series            | LAB Series      | LNTB Series         | LAF Series      | LAK Series    | LWD Series  | LCM Series  | LAX Series     |
|------------------------|-----------------------------|--|------------------------|-----------------|---------------------|-----------------|---------------|-------------|-------------|----------------|
| 3 mm                   | Dynamic load                | 11 kg                                    | 2.3 kg                 |                 | 2.3 kg              |                 |               |             |             |                |
|                        | Static friction drag torque | free wheeling                            | 0.001 - 0.004Nm        |                 | 0.001 - 0.004Nm     |                 |               |             |             |                |
| 5 mm                   | Dynamic load                | 11 kg                                    | 2.3 kg                 |                 | 2.3 kg              |                 |               | 4.5 kg      | 2.3 kg      |                |
|                        | Static friction drag torque | free wheeling                            | 0.001 - 0.004Nm        |                 | 0.001 - 0.004Nm     |                 |               | 0.03 Nm max | 0.03 Nm     |                |
| 6 mm                   | Dynamic load                | 20 kg                                    | 4.6 kg                 | 2.3 kg          | 4.6 kg              | 2.3 kg          |               | 4.5 kg      | 2.3 kg      |                |
|                        | Static friction drag torque | free wheeling                            | 0.004 - 0.014Nm        | 0.004 - 0.014Nm | 0.004 - 0.014Nm     | 0.002Nm         |               | 0.03Nm max  | 0.03Nm      |                |
| 8 mm                   | Dynamic load                | 35 kg                                    | 10 kg                  | 5 kg            | 10 kg               | 5 kg            | 10 kg         | 11.3 kg     | 3.6 kg      |                |
|                        | Static friction drag torque | free wheeling                            | 0.007 - 0.02Nm         | 0.01 - 0.02Nm   | 0.01 - 0.02Nm       | 0.01 - 0.03Nm   | 0.01 - 0.02Nm | 0.04Nm max  | 0.04Nm      |                |
| 10 mm                  | Dynamic load                | 35 kg                                    | 10 kg                  | 5 kg            | 10 kg               | 5 kg            | 10 kg         | 11.3 kg     | 3.6 kg      |                |
|                        | Static friction drag torque | free wheeling                            | 0.007 - 0.02Nm         | 0.01 - 0.02Nm   | 0.01 - 0.02Nm       | 0.01 - 0.03Nm   | 0.01 - 0.02Nm | 0.04Nm max  | 0.04Nm      |                |
| 11 mm                  | Dynamic load                | 40 kg                                    |                        | 7 kg            | 13 kg               | 7 kg            |               | 34 kg       |             |                |
|                        | Static friction drag torque | free wheeling                            |                        | 0.014 - 0.03Nm  | 0.007 - 0.02Nm      | 0.014 - 0.04Nm  |               | 0.06Nm max  |             |                |
| 13 mm                  | Dynamic load                | 68 kg                                    |                        | 11 kg           | 45 kg               | 11 kg           |               | 34 kg       |             | 68 kg          |
|                        | Static friction drag torque | free wheeling                            |                        | 0.014 - 0.03Nm  | 0.014 - 0.04Nm      | 0.02 - 0.05Nm   |               | 0.06Nm max  |             | 0.014 - 0.04Nm |
| 16 mm                  | Dynamic load                | 100 kg                                   |                        | 16 kg           | 56 kg               | 16 kg           |               |             |             | 113 kg         |
|                        | Static friction drag torque | free wheeling                            |                        | 0.02 - 0.05Nm   | 0.014 - 0.04Nm      | 0.028 - 0.055Nm |               |             |             | 0.014 - 0.04Nm |
| 19 mm                  | Dynamic load                | 160 kg                                   |                        | 25 kg           | 68 kg               |                 |               |             |             | 159 kg         |
|                        | Static friction drag torque | free wheeling                            |                        | 0.03 - 0.063Nm  | 0.02 - 0.05Nm       |                 |               |             |             | 0.02 - 0.05Nm  |
| <b>See Pages</b>       |                             | <b>7-12 to 7-14</b>                      | <b>7-15 &amp; 7-16</b> | <b>7-17</b>     | <b>7-18 to 7-20</b> | <b>7-21</b>     | <b>7-22</b>   | <b>7-23</b> | <b>7-24</b> | <b>7-25</b>    |

<sup>1</sup> LBF available in 3 mm and 5 mm screw diameter only.

<sup>2</sup> LPX available from 6mm screw diameter.

### **i** Information

- For technical information see [pages T7-1 to T7-5](#)
- Larger screw diameters available, contact us



| Compatible Nut Styles     | Lead mm | Nominal Screw Diameter | Part Number     | Root Dia mm | Outside Diameter | Efficiency %* | Left Hand Available |
|---------------------------|---------|------------------------|-----------------|-------------|------------------|---------------|---------------------|
| LBF                       | 0.30    | 2 mm                   | <b>2-0012</b>   | 1.73        | 2.01             | 24**          |                     |
|                           | 0.40    |                        | <b>2-0016</b>   | 1.47        | 1.91             | 30**          |                     |
|                           | 0.50    |                        | <b>2-M005</b>   | 1.45        | 1.96             | 36**          |                     |
|                           | 1.00    |                        | <b>2-M010</b>   | 1.50        | 2.01             | 52**          |                     |
|                           | 2.00    |                        | <b>2-M020</b>   | 1.45        | 1.96             | 66**          |                     |
| LBF, LNTG, LNTB           | 0.61    | 3.2 mm                 | <b>3.2-0024</b> | 2.36        | 3.28             | 44            | ✓<br>LH only        |
|                           | 1.00    |                        | <b>3.2-M010</b> | 2.39        | 3.28             | 57            |                     |
|                           | 1.22    |                        | <b>3.2-0048</b> | 2.36        | 3.28             | 61            |                     |
|                           | 1.91    |                        | <b>3.2-0075</b> | 2.36        | 3.28             | 70            |                     |
|                           | 2.44    |                        | <b>3.2-0096</b> | 2.36        | 3.28             | 75            |                     |
|                           | 3.18    |                        | <b>3.2-0125</b> | 1.98        | 3.18             | 80            |                     |
| LBF, LNTG, LNTB           | 0.50    | 3.3 mm                 | <b>3.3-M005</b> | 2.64        | 3.35             | 42            |                     |
|                           | 1.00    |                        | <b>3.3-M010</b> | 2.03        | 3.35             | 61            |                     |
|                           | 2.00    |                        | <b>3.3-M020</b> | 2.03        | 3.35             | 75            |                     |
|                           | 4.00    |                        | <b>3.3-M040</b> | 2.03        | 3.35             | 84            |                     |
|                           | 8.00    |                        | <b>3.3-M080</b> | 2.03        | 3.35             | 87            |                     |
| LBF, LNTG, LNTB           | 0.30    | 3.6 mm                 | <b>3.6-0012</b> | 3.12        | 3.56             | 26            |                     |
|                           | 0.61    |                        | <b>3.6-0024</b> | 2.67        | 3.56             | 43            |                     |
|                           | 1.22    |                        | <b>3.6-0048</b> | 2.06        | 3.56             | 62            |                     |
|                           | 2.44    |                        | <b>3.6-0096</b> | 2.06        | 3.56             | 75            |                     |
|                           | 10.00   |                        | <b>3.6-M100</b> | 2.59        | 3.56             | 86            |                     |
| LBF, LNTG, LNTB           | 0.84    | 4 mm                   | <b>4-0033</b>   | 2.95        | 3.96             | 45            | ✓<br>LH Only        |
|                           | 1.27    |                        | <b>4-0050</b>   | 2.44        | 3.96             | 59            |                     |
|                           | 2.39    |                        | <b>4-0094</b>   | 3.25        | 4.17             | 67            |                     |
|                           | 3.18    |                        | <b>4-0125</b>   | 3.30        | 4.27             | 74            |                     |
|                           | 6.35    |                        | <b>4-0250</b>   | 3.30        | 3.96             | 83            |                     |
|                           | 9.53    |                        | <b>4-0375</b>   | 3.30        | 3.96             | 85            |                     |
|                           | 12.7    |                        | <b>4-0500</b>   | 3.30        | 3.96             | 86            |                     |
| LNTB, LNTG, LBF, LWD, LCM | 0.50    | 5 mm                   | <b>5-M005</b>   | 4.14        | 4.78             | 30            | ✓                   |
|                           | 0.64    |                        | <b>5-0025</b>   | 3.81        | 4.78             | 39            |                     |
|                           | 1.00    |                        | <b>5-M010</b>   | 3.66        | 4.78             | 47            |                     |
|                           | 1.27    |                        | <b>5-0050</b>   | 3.15        | 4.78             | 58            |                     |
|                           | 2.54    |                        | <b>5-0100</b>   | 3.45        | 4.78             | 69            |                     |
|                           | 4.76    |                        | <b>5-0188</b>   | 4.24        | 4.78             | 78            |                     |
|                           | 5.08    |                        | <b>5-0200</b>   | 3.15        | 4.78             | 82            |                     |
|                           | 9.53    |                        | <b>5-0375</b>   | 4.09        | 4.78             | 84            |                     |
|                           | 10.16   |                        | <b>5-0400</b>   | 3.15        | 4.78             | 84            |                     |
|                           | 10.85   |                        | <b>5-0427</b>   | 4.11        | 4.78             | 85            |                     |
|                           | 12.70   |                        | <b>5-0500</b>   | 3.61        | 4.78             | 86            |                     |

\* Listed efficiencies are theoretical values based on a TFE coated leadscrew

\*\* Listed efficiencies for 2mm diameter leadscrews are theoretical values based on non-coated leadscrews

Note: Thread lengths can be specified up to 4m, depending on diameter and lead.



| Compatible Nut Styles                    | Lead mm       | Nominal Screw Diameter | Part Number     | Root Dia mm | Outside Diameter | Efficiency | Left Hand Available |   |
|--|---------------|------------------------|-----------------|-------------|------------------|------------|---------------------|---|
|  |               |                        |                 |             |                  | %*         |                     |   |
| LNTB, LNTG, LBF, LWD                     | 0.61          | 5.6 mm                 | <b>5.6-0024</b> | 4.60        | 5.54             | 31         |                     |   |
|  | 0.79          |                        | <b>5.6-0031</b> | 4.06        | 5.18             | 39         |                     |   |
|  | 1.22          |                        | <b>5.6-0048</b> | 3.96        | 5.49             | 50         |                     |   |
|  | 1.27          |                        | <b>5.6-0050</b> | 3.43        | 5.08             | 52         |                     |   |
|  | 1.59          |                        | <b>5.6-0063</b> | 3.61        | 5.54             | 60         |                     |   |
|  | 2.44          |                        | <b>5.6-0096</b> | 3.96        | 5.54             | 66         |                     |   |
|  | 4.88          |                        | <b>5.6-0192</b> | 3.96        | 5.54             | 78         |                     |   |
|  | 6.35          |                        | <b>5.6-0250</b> | 3.56        | 5.18             | 81         |                     | ✓ |
|  | 9.75          |                        | <b>5.6-0384</b> | 4.04        | 5.54             | 86         |                     |   |
| LCM, LAF, LAB, LNTB, LNTG, LPX, LWD      | 0.61          | 6 mm                   | <b>6-0024</b>   | 5.54        | 6.35             | 28         |                     |   |
|  | 0.64          |                        | <b>6-0025</b>   | 5.44        | 6.35             | 30         |                     |   |
|  | 0.79          |                        | <b>6-0031</b>   | 5.28        | 6.35             | 34         |                     |   |
|  | 1.00          |                        | <b>6-M010</b>   | 4.83        | 6.35             | 40         |                     |   |
|  | 1.22          |                        | <b>6-0048</b>   | 4.83        | 6.35             | 45         |                     |   |
|  | 1.27          |                        | <b>6-0050</b>   | 4.85        | 6.35             | 46         |                     | ✓ |
|  | 1.50          |                        | <b>6-M015</b>   | 4.37        | 6.35             | 52         |                     |   |
|  | 1.59          |                        | <b>6-0063</b>   | 4.32        | 6.35             | 52         |                     |   |
|  | 2.00          |                        | <b>6-M020</b>   | 4.32        | 6.35             | 59         |                     |   |
|  | 2.44          |                        | <b>6-0096</b>   | 4.83        | 6.35             | 61         |                     |   |
|  | 2.54          |                        | <b>6-0100</b>   | 4.83        | 6.35             | 62         |                     |   |
|  | 3.00          |                        | <b>6-M030</b>   | 4.45        | 6.35             | 68         |                     |   |
|  | 3.18          |                        | <b>6-0125</b>   | 4.83        | 6.35             | 67         |                     |   |
|  | 5.00          |                        | <b>6-M050</b>   | 4.37        | 6.35             | 72         |                     |   |
|  | 5.08          |                        | <b>6-0200</b>   | 4.32        | 6.35             | 65         |                     |   |
|  | 6.35          |                        | <b>6-0250</b>   | 4.27        | 6.35             | 79         |                     | ✓ |
|  | 7.94          |                        | <b>6-0313</b>   | 4.67        | 6.35             | 81         |                     |   |
|  | 8.46          |                        | <b>6-0333</b>   | 4.32        | 6.35             | 82         |                     |   |
|  | 10.00         |                        | <b>6-M100</b>   | 4.32        | 6.35             | 78         |                     |   |
|  | 10.16         |                        | <b>6-0400</b>   | 4.32        | 6.35             | 84         |                     |   |
| 12.70                                    | <b>6-0500</b> | 4.29                   | 6.35            | 85          | ✓                |            |                     |   |
| 19.05                                    | <b>6-0750</b> | 4.32                   | 6.35            | 86          |                  |            |                     |   |
| 25.40                                    | <b>6-1000</b> | 4.32                   | 6.35            | 84          | ✓                |            |                     |   |
| LCM, LAF, LAB, LNTB, LNTG, LPX, LWD, LAK | 1.00          | 8 mm                   | <b>8-M010</b>   | 6.63        | 8.00             | 34         |                     |   |
|  | 1.44          |                        | <b>8-0057</b>   | 6.17        | 8.00             | 43         |                     |   |
|  | 1.88          |                        | <b>8-0074</b>   | 5.36        | 7.92             | 51         |                     |   |
|  | 2.82          |                        | <b>8-0111</b>   | 5.89        | 7.92             | 60         |                     |   |
|  | 4.24          |                        | <b>8-0167</b>   | 5.36        | 7.92             | 69         |                     |   |
|  | 6.35          |                        | <b>8-0250</b>   | 5.94        | 7.92             | 76         |                     |   |
|  | 12.70         |                        | <b>8-0500</b>   | 5.89        | 7.92             | 83         |                     |   |
|  | 20.32         |                        | <b>8-0800</b>   | 6.17        | 7.77             | 86         |                     |   |
| LCM, LAF, LAB, LAK, LNTB, LNTG, LPX, LWD | 0.64          | 10 mm                  | <b>10-0025</b>  | 8.56        | 9.53             | 21         |                     |   |
|  | 1.00          |                        | <b>10-M010</b>  | 8.89        | 10.01            | 28         |                     |   |
|  | 1.06          |                        | <b>10-0042</b>  | 8.13        | 9.53             | 34         |                     |   |
|  | 1.27          |                        | <b>10-0050</b>  | 7.65        | 9.53             | 36         |                     |   |
|  | 1.40          |                        | <b>10-0055</b>  | 7.70        | 9.53             | 38         |                     |   |
|  |               |                        |                 |             |                  |            |                     | ✓ |

\* Listed efficiencies are theoretical values based on a TFE coated leadscrew

Note: Thread lengths can be specified up to 4 m, depending on diameter and lead.



| Compatible Nut Styles                    | Lead mm        | Nominal Screw Diameter | Part Number    | Root Dia mm | Outside Diameter | Efficiency | Left Hand Available |
|--|----------------|------------------------|----------------|-------------|------------------|------------|---------------------|
|  |                |                        |                |             |                  | %*         |                     |
| LCM, LAF, LAB, LAK, LNTB, LNTG, LPX, LWD | 1.50           | 10 mm                  | <b>10-M015</b> | 7.95        | 9.88             | 38         | ✓                   |
|  | 1.73           |                        | <b>10-0068</b> | 7.49        | 9.86             | 42         |                     |
|  | 2.00           |                        | <b>10-M020</b> | 6.71        | 9.53             | 47         |                     |
|  | 2.12           |                        | <b>10-0083</b> | 7.44        | 9.53             | 48         |                     |
|  | 2.54           |                        | <b>10-0100</b> | 6.76        | 9.53             | 53         | ✓                   |
|  | 3.18           |                        | <b>10-0125</b> | 7.49        | 9.53             | 59         |                     |
|  | 4.00           |                        | <b>10-M040</b> | 6.96        | 9.53             | 65         |                     |
|  | 4.23           |                        | <b>10-0167</b> | 6.63        | 9.42             | 61         |                     |
|  | 5.00           |                        | <b>10-M050</b> | 6.76        | 9.53             | 69         |                     |
|  | 5.08           |                        | <b>10-0200</b> | 6.76        | 9.53             | 69         | ✓                   |
|  | 6.35           |                        | <b>10-0250</b> | 6.81        | 9.53             | 70         |                     |
|  | 7.62           |                        | <b>10-0300</b> | 6.48        | 9.53             | 76         |                     |
|  | 8.46           |                        | <b>10-0333</b> | 6.22        | 9.53             | 78         |                     |
|  | 9.22           |                        | <b>10-0363</b> | 6.60        | 9.53             | 79         | ✓                   |
|  | 9.53           |                        | <b>10-0375</b> | 6.73        | 9.53             | 79         |                     |
|  | 10.00          |                        | <b>10-M100</b> | 6.60        | 9.53             | 79         |                     |
|  | 10.16          |                        | <b>10-0400</b> | 7.44        | 9.53             | 79         |                     |
|  | 12.00          |                        | <b>10-M120</b> | 7.29        | 9.86             | 82         |                     |
|  | 12.70          |                        | <b>10-0500</b> | 6.73        | 9.86             | 81         | ✓                   |
|  | 16.94          |                        | <b>10-0667</b> | 6.93        | 9.53             | 83         |                     |
| 19.05                                    | <b>10-0750</b> | 6.93                   | 9.86           | 84          |                  |            |                     |
| 25.00                                    | <b>10-M250</b> | 6.65                   | 9.53           | 84          |                  |            |                     |
| 25.40                                    | <b>10-1000</b> | 6.45                   | 9.73           | 84          |                  |            |                     |
| 30.48                                    | <b>10-1200</b> | 6.45                   | 9.73           | 84          | ✓                |            |                     |
| 31.75                                    | <b>10-1250</b> | 7.06                   | 9.53           | 84          |                  |            |                     |
| 38.10                                    | <b>10-1500</b> | 6.71                   | 9.53           | 83          |                  |            |                     |
| LAF, LAB, LNTB, LPX, LWD                 | 1.27           | 11 mm                  | <b>11-0050</b> | 9.19        | 11.10            | 30         |                     |
|  | 1.59           |                        | <b>11-0063</b> | 9.09        | 11.07            | 38         | ✓                   |
|  | 2.00           |                        | <b>11-M020</b> | 9.50        | 11.99            | 42         |                     |
|  | 2.82           |                        | <b>11-0111</b> | 8.31        | 11.10            | 52         |                     |
|  | 3.00           |                        | <b>11-M030</b> | 9.22        | 11.13            | 52         |                     |
|  | 3.18           |                        | <b>11-0125</b> | 9.07        | 11.13            | 54         |                     |
|  | 5.00           |                        | <b>11-M050</b> | 8.00        | 11.13            | 65         |                     |
|  | 6.00           |                        | <b>11-M060</b> | 7.95        | 11.00            | 70         |                     |
|  | 6.35           |                        | <b>11-0250</b> | 8.26        | 11.23            | 70         |                     |
|  | 7.80           |                        | <b>11-0307</b> | 8.71        | 11.30            | 73         |                     |
|  | 8.26           |                        | <b>11-0325</b> | 8.69        | 11.28            | 74         |                     |
|  | 10.00          |                        | <b>11-M100</b> | 8.41        | 11.33            | 78         |                     |
|  | 12.00          |                        | <b>11-M120</b> | 8.08        | 11.13            | 80         |                     |
|  | 12.70          |                        | <b>11-0500</b> | 8.31        | 11.48            | 80         |                     |
|  | 15.62          |                        | <b>11-0615</b> | 9.55        | 12.07            | 82         |                     |

\* Listed efficiencies are theoretical values based on a TFE coated leadscrew  
 Note: Thread lengths can be specified up to 4 m, depending on diameter and lead.



| Compatible Nut Styles         | Lead mm | Nominal Screw Diameter | Part Number | Root Dia mm | Outside Diameter | Efficiency | Left Hand Available |
|-------------------------------|---------|------------------------|-------------|-------------|------------------|------------|---------------------|
|                               |         |                        |             |             |                  | %*         |                     |
| LAF, LAB, LNTB, LAX, LPX, LWD | 1.27    | 13 mm                  | 13-0050     | 11.00       | 12.57            | 29         |                     |
|                               | 2.00    |                        | 13-M020     | 9.02        | 12.01            | 41         |                     |
|                               | 2.50    |                        | 13-M025     | 9.73        | 12.70            | 46         |                     |
|                               | 2.54    |                        | 13-0100     | 9.25        | 12.45            | 46         | ✓                   |
|                               | 3.18    |                        | 13-0125     | 9.50        | 12.70            | 51         |                     |
|                               | 4.00    |                        | 13-M040     | 9.75        | 12.70            | 58         |                     |
|                               | 4.06    |                        | 13-0160     | 9.86        | 12.70            | 67         |                     |
|                               | 4.23    |                        | 13-0167     | 9.75        | 12.70            | 58         |                     |
|                               | 5.00    |                        | 13-M050     | 9.27        | 12.70            | 62         |                     |
|                               | 5.08    |                        | 13-0200     | 9.30        | 12.50            | 63         | ✓                   |
|                               | 6.35    |                        | 13-0250     | 9.70        | 12.70            | 67         |                     |
|                               | 8.46    |                        | 13-0333     | 9.19        | 12.62            | 73         | ✓                   |
|                               | 10.00   |                        | 13-M100     | 9.19        | 12.62            | 76         |                     |
|                               | 10.16   |                        | 13-0400     | 9.25        | 12.62            | 76         |                     |
|                               | 12.70   |                        | 13-0500     | 8.94        | 12.40            | 79         |                     |
|                               | 16.00   |                        | 13-M160     | 9.50        | 12.70            | 80         |                     |
|                               | 19.05   |                        | 13-0750     | 10.13       | 13.34            | 83         |                     |
|                               | 20.32   |                        | 13-0800     | 9.40        | 12.70            | 83         |                     |
|                               | 25.00   |                        | 13-M250     | 9.37        | 12.70            | 84         |                     |
|                               | 25.40   |                        | 13-1000     | 9.45        | 12.45            | 84         | ✓                   |
| 38.10                         | 13-1500 | 9.50                   | 12.45       | 85          |                  |            |                     |
| 50.80                         | 13-2000 | 9.60                   | 12.40       | 87          |                  |            |                     |
| LAF, LAB LNTB, LAX LPX        | 2.54    | 16 mm                  | 16-0100     | 12.65       | 15.62            | 40         |                     |
|                               | 3.18    |                        | 16-0125     | 11.94       | 15.88            | 45         | ✓                   |
|                               | 5.08    |                        | 16-0200     | 12.57       | 15.88            | 53         |                     |
|                               | 6.35    |                        | 16-0250     | 11.91       | 15.88            | 63         |                     |
|                               | 8.00    |                        | 16-M080     | 12.52       | 15.93            | 68         |                     |
|                               | 12.70   |                        | 16-0500     | 12.14       | 15.88            | 76         | ✓                   |
|                               | 16.00   |                        | 16-M160     | 12.47       | 15.88            | 78         |                     |
|                               | 25.40   |                        | 16-1000     | 12.22       | 15.88            | 83         |                     |
|                               | 38.10   |                        | 16-1500     | 12.67       | 15.88            | 85         |                     |
|                               | 50.80   |                        | 16-2000     | 12.67       | 15.88            | 86         | ✓                   |
| LAB, LNTB LAX, LPX            | 1.59    | 19 mm                  | 19-0063     | 17.04       | 19.05            | 25         |                     |
|                               | 2.50    |                        | 19-M025     | 15.90       | 18.85            | 35         |                     |
|                               | 2.54    |                        | 19-0100     | 15.85       | 18.95            | 35         | ✓                   |
|                               | 4.23    |                        | 19-0167     | 16.38       | 18.47            | 47         |                     |
|                               | 5.00    |                        | 19-M050     | 15.85       | 18.92            | 51         |                     |
|                               | 5.08    |                        | 19-0200     | 16.05       | 18.82            | 52         |                     |
|                               | 6.35    |                        | 19-0250     | 16.23       | 18.57            | 57         |                     |
|                               | 7.00    |                        | 19-M070     | 15.85       | 19.05            | 59         |                     |
|                               | 8.46    |                        | 19-0333     | 15.85       | 19.05            | 64         |                     |
|                               | 12.70   |                        | 19-0500     | 15.82       | 18.90            | 73         |                     |
|                               | 14.00   |                        | 19-M140     | 15.85       | 19.05            | 73         |                     |
|                               | 15.00   |                        | 19-M150     | 15.82       | 19.02            | 74         |                     |

\* Listed efficiencies are theoretical values based on a TFE coated leadscrew  
 Note: Thread lengths can be specified up to 4 m, depending on diameter and lead.



| Compatible Nut Styles     | Lead mm | Nominal Screw Diameter | Part Number    | Root Dia mm | Outside Diameter | Efficiency | Left Hand Available |
|---------------------------|---------|------------------------|----------------|-------------|------------------|------------|---------------------|
|                           |         |                        |                |             |                  | %*         |                     |
| LAB<br>LNTB<br>LAX<br>LPX | 18.00   | 19 mm                  | <b>19-M180</b> | 16.51       | 19.81            | 77         |                     |
|                           | 19.00   |                        | <b>19-M190</b> | 13.89       | 17.07            | 80         |                     |
|                           | 20.00   |                        | <b>19-M200</b> | 16.46       | 19.81            | 78         |                     |
|                           | 20.32   |                        | <b>19-0800</b> | 15.70       | 19.05            | 79         |                     |
|                           | 24.00   |                        | <b>19-M240</b> | 16.08       | 18.64            | 80         |                     |
|                           | 25.40   |                        | <b>19-1000</b> | 15.72       | 18.87            | 81         | ✓                   |
|                           | 38.10   |                        | <b>19-1500</b> | 14.99       | 18.08            | 84         | ✓                   |
|                           | 50.00   |                        | <b>19-M500</b> | 15.75       | 19.08            | 84         |                     |
|                           | 50.80   |                        | <b>19-2000</b> | 15.52       | 18.85            | 84         | ✓                   |
|                           | 60.96   |                        | <b>19-2400</b> | 15.75       | 19.05            | 84         | ✓                   |
|                           | 92.00   |                        | <b>19-M920</b> | 16.10       | 19.05            | 87         | ✓                   |

\* Listed efficiencies are theoretical values based on a TFE coated leadscrew  
 Note: Thread lengths can be specified up to 4m, depending on diameter and lead.

## **i** Information

- Larger screw diameters available, visit [www.reliance.co.uk/shop](http://www.reliance.co.uk/shop)
- For leadscrew and nut ordering configurations - see page 7-3
- For leadscrew end modifications - see pages 7-27 to 7-35
- For product overview - see pages 7-2 to 7-6
- For technical information - see pages T7-1 to T7-5



All dimensions in mm  
 General tolerances  $\pm 0.5$  mm  
 Detailed tolerances: Please contact us  
 Material: Polyacetal

**Associated Products**  
 Reli-a-Flex® couplings: page 8-6  
 Linear slides: page 9-1  
 Intelligent motors: page 2-2  
 Plain bearings: page 12-1

Leadscrew & Nut Assemblies

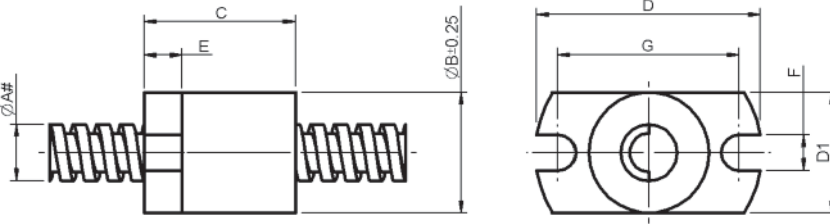

## Part number selection table - LBB and LBF series, barrel and flange mount

| Nut Series | Nominal Screw ØA# | Nut ØB | Nut Length C | Flange D | Flange Width E | Flange Height D1 | Slot F | Centres G | Dynamic Load kg | Drag Torque Nm |
|------------|-------------------|--------|--------------|----------|----------------|------------------|--------|-----------|-----------------|----------------|
| LBB2-      | 2.0               | 5.5    | 8            | --       | --             | 5.08             | --     | --        | 4.5             | Free wheeling  |
| LBF2-      | 2.0               | 5.5    | 8            | 11.9     | 2.0            | 5.5              | 1.80   | 9.00      | 4.5             |                |
| LBF3-      | 3 <sup>1</sup>    | 10.2   | 13           | 19.1     | 3.2            | 10.2             | 3.05   | 15.24     | 11              |                |
| LBF4-      | 4.0               |        |              |          |                |                  |        |           |                 |                |
| LBF5-      | 5 <sup>2</sup>    |        |              |          |                |                  |        |           |                 |                |

<sup>1</sup>LBF3 for  $\varnothing$  3.2, 3.3 and 3.6      <sup>2</sup>LBF5 for  $\varnothing$  5.0 and 5.6

The LBB nut series is a flangeless style barrel nut with two flats at 5.08mm diametrically opposed running the full length of the nut.

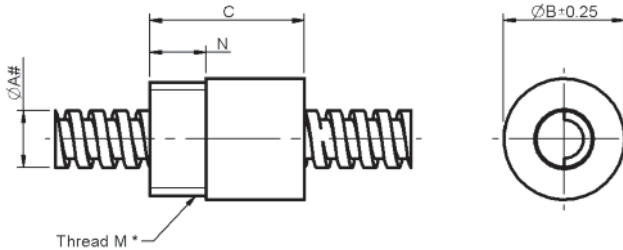

## Part number selection table - LBY series, thread mount

| Nut Series | Nominal Screw ØA# | Nut ØB | Nut Length C | Thread M* | Thread Length N | Dynamic Load kg | Drag Torque Nm |
|------------|-------------------|--------|--------------|-----------|-----------------|-----------------|----------------|
| LBY3-      | 3 <sup>1</sup>    | 10.2   | 13           | 3/8-24    | 4.75            | 11              | Free wheeling  |
| LBY4-      | 4.0               |        |              |           |                 |                 |                |
| LBY5-      | 5 <sup>2</sup>    |        |              |           |                 |                 |                |

<sup>1</sup>LBY3 for  $\varnothing$  3.2, 3.3 and 3.6      <sup>2</sup>LBY5 for  $\varnothing$  5.0 and 5.6

\*Thread shown imperial as standard, metric available, please specify diameter and pitch

# For the full range of nominal diameters, see table on pages 7-7 to 7-11





**Associated Products**  
 Reli-a-Flex® couplings: page 8-6  
 Linear slides: page 9-1  
 Intelligent motors: page 2-2  
 Plain bearings: page 12-1

All dimensions in mm  
 General tolerances  $\pm 0.5$  mm  
 Detailed tolerances: Please contact us  
 Material: Polyacetal

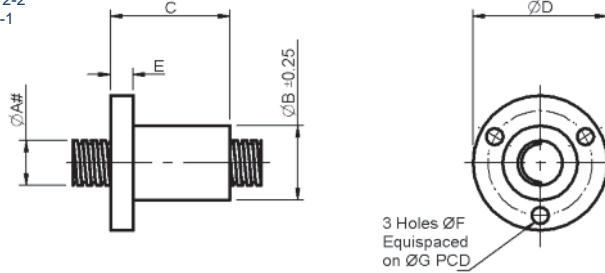

### Part number selection table - LPX series, flange mount

| Nut Series | Nominal Screw ØA# | Nut ØB | Nut Length C | Flange ØD | Flange Width E | Hole Dia ØF | Mounting Holes PCD ØG | Dynamic Load kg | Drag Torque Nm |
|------------|-------------------|--------|--------------|-----------|----------------|-------------|-----------------------|-----------------|----------------|
| LPX6-      | 6.4               | 12.7   | 25.4         | 25.4      | 4.8            | 3.56        | 19.05                 | 20              | Free wheeling  |
| LPX8-      | 8.0               | 15.9   |              | 28.7      |                |             | 22.23                 | 35              |                |
| LPX10-     | 9.6               |        |              | 38        |                |             | 38.1                  | 5.16            |                |
| LPX11-     | 11.3              | 68     |              |           |                |             |                       |                 |                |
| LPX13-     | 12.7              |        | 100          |           |                |             |                       |                 |                |
| LPX16-     | 15.9              | 30.18  |              |           |                | 160         |                       |                 |                |
| LPX19-     | 19.1              | 28.4   | 51           | 44.4      | 6.4            | 36.53       | 160                   |                 |                |

Screw sizes 22 and 24 mm available

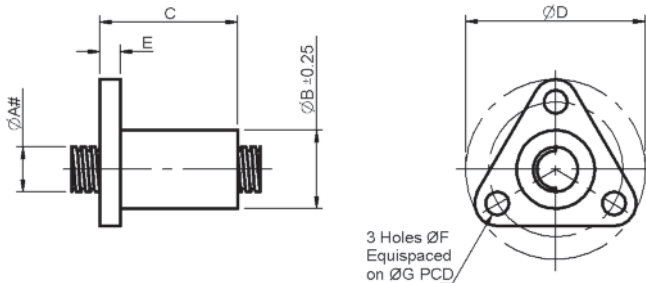

### Part number selection table - LPXZ series, flange mount

| Nut Series | Nominal Screw ØA# | Nut ØB | Nut Length C | Flange ØD | Flange Width E | Hole Dia ØF | Mounting Holes PCD ØG | Dynamic Load kg | Drag Torque Nm |
|------------|-------------------|--------|--------------|-----------|----------------|-------------|-----------------------|-----------------|----------------|
| LPXZ6-     | 6.4               | 12.7   | 25.4         | 25.4      | 4.3            | 3.63        | 19.05                 | 20              | Free wheeling  |
| LPXZ8-     | 8.0               | 16.6   | 48.3         | 38.1      |                | 5.00        | 28.58                 | 35              |                |
| LPXZ10-    | 9.6               |        |              |           |                |             |                       | 40              |                |
| LPXZ11-    | 11.3              | 19.1   | 68           |           |                |             |                       |                 |                |
| LPXZ13-    | 12.7              |        |              | 100       |                |             |                       |                 |                |



All dimensions in mm  
 General tolerances  $\pm 0.5$  mm  
 Detailed tolerances: Please contact us  
 Material: Polyacetal

**Associated Products**  
 Reli-a-Flex® couplings: page 8-6  
 Linear slides: page 9-1  
 Intelligent motors: page 2-2  
 Plain bearings: page 12-1

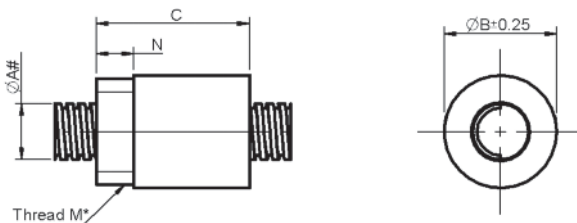

Leadscrew & Nut Assemblies

### Part number selection table - LPXY series, thread mount

| Nut Series | Nominal Screw ØA# | Nut ØB | Nut Length C | Thread M* | Thread Length N | Dynamic Load kg | Drag Torque Nm |
|------------|-------------------|--------|--------------|-----------|-----------------|-----------------|----------------|
| LPXY6-     | 6.4               | 15.9   | 25.4         | 9/16-18   | 4.75            | 20              | Free wheeling  |
| LPXY8-     | 8.0               | 19.1   |              | 5/8-18    | 6.35            | 35              |                |
| LPXY10-    | 9.6               | 25.4   | 38           | 15/16-16  | 9.53            | 40              |                |
| LPXY11-    | 11.3              |        |              |           |                 | 68              |                |
| LPXY13-    | 12.7              |        |              |           |                 | 100             |                |
| LPXY16-    | 15.9              | 38.1   | 51           | 1 3/8-16  | 12.70           | 160             |                |
| LPXY19-    | 19.1              |        |              |           |                 |                 |                |

Note: All LPX, LPXZ and LPXY nuts are free wheeling

\*Thread shown imperial as standard, metric available, please specify diameter and pitch  
 Screw sizes 22 and 24 mm available

# For the full range of nominal diameters, see table on pages 7-7 to 7-11



### Associated Products

Reli-a-Flex® couplings: page 8-6  
 Linear slides: page 9-1  
 Intelligent motors: page 2-2  
 Plain bearings: page 12-1

All dimensions in mm  
 General tolerances  $\pm 0.5$  mm  
 Detailed tolerances: Please contact us  
 Material: Polyacetal

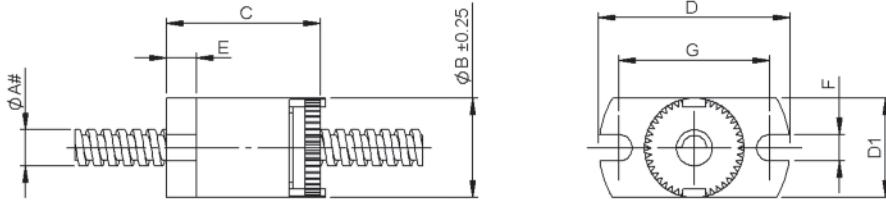

### Part number selection table - LNTGF series, flange mount

| Nut Series | Nominal Screw $\phi A\#$ | Nut $\phi B$ | Nut Length C | Flange D | Flange Width E | Flange Height D1 | Slot F | Centres G | Dynamic Load kg | Drag Torque Nm |
|------------|--------------------------|--------------|--------------|----------|----------------|------------------|--------|-----------|-----------------|----------------|
| LNTGF3-    | 3 <sup>1</sup>           | 10.2         | 12.7         | 19.1     | 3.2            | 10.2             | 3.05   | 15.24     | 2.3             | 0.004          |
| LNTGF4-    | 4.0                      |              |              |          |                |                  |        |           |                 |                |
| LNTGF5-    | 5 <sup>2</sup>           |              |              |          |                |                  |        |           |                 |                |

<sup>1</sup>LNTGF3 for  $\phi$  3.2, 3.3 and 3.6    <sup>2</sup>LNTGF5 for  $\phi$  5.0 and 5.6

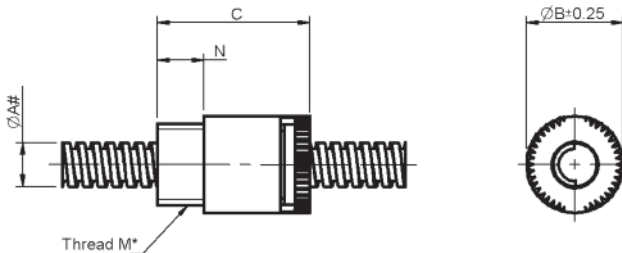

### Part number selection table - LNTGY series, thread mount

| Nut Series | Nominal Screw $\phi A\#$ | Nut $\phi B$ | Nut Length C | Thread M* | Thread Length N | Dynamic Load kg | Drag Torque Nm |
|------------|--------------------------|--------------|--------------|-----------|-----------------|-----------------|----------------|
| LNTGY3-    | 3 <sup>1</sup>           | 10.2         | 12.7         | 3/8-24    | 4.06            | 2.3             | 0.004          |
| LNTGY4-    | 4.0                      |              |              |           |                 |                 |                |
| LNTGY5-    | 5 <sup>2</sup>           |              |              |           |                 |                 |                |

<sup>1</sup>LNTGY3 for  $\phi$  3.2, 3.3 and 3.6    <sup>2</sup>LNTGY5 for  $\phi$  5.0 and 5.6

\*Thread shown imperial as standard, metric available, please specify diameter and pitch

# For the full range of nominal diameters, see table on pages 7-7 to 7-11



All dimensions in mm  
 General tolerances  $\pm 0.5$  mm  
 Detailed tolerances: Please contact us  
 Material: Polyacetal

**Associated Products**  
 Reli-a-Flex® couplings: page 8-6  
 Linear slides: page 9-1  
 Intelligent motors: page 2-2  
 Plain bearings: page 12-1

Leadscrew & Nut Assemblies

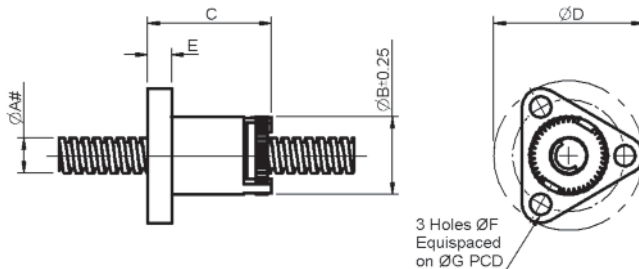

## Part number selection table - LNTGF series, flange mount

| Nut Series | Nominal Screw $\varnothing A\#$ | Nut $\varnothing B$ | Nut Length C | Flange $\varnothing D$ | Flange Width E | Hole Dia $\varnothing F$ | Mounting Holes PCD $\varnothing G$ | Dynamic Load kg | Drag Torque Nm |
|------------|---------------------------------|---------------------|--------------|------------------------|----------------|--------------------------|------------------------------------|-----------------|----------------|
| LNTGF6-    | 6.4                             | 20.3                | 20.3         | 25.4                   | 4.0            | 3.63                     | 19.1                               | 4.5             | 0.004-0.014    |
| LNTGF8-    | 8.0                             |                     | 25.4         | 38.1                   | 5.1            | 5.00                     | 28.6                               | 9.1             | 0.007-0.02     |
| LNTGF10-   | 9.6                             |                     | 25.4         | 38.1                   | 5.1            | 5.00                     | 28.6                               | 9.1             | 0.007-0.02     |

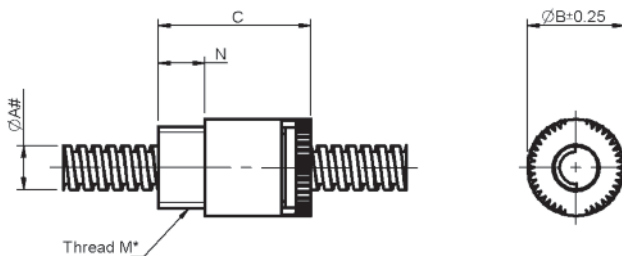

## Part number selection table - LNTGY series, thread mount

| Nut Series | Nominal Screw $\varnothing A\#$ | Nut $\varnothing B$ | Nut Length C | Thread M* | Thread Length N | Dynamic Load kg | Drag Torque Nm |
|------------|---------------------------------|---------------------|--------------|-----------|-----------------|-----------------|----------------|
| LNTGY6-    | 6.4                             | 20.3                | 22           | 7/16-20   | 6.35            | 4.5             | 0.004-0.014    |
| LNTGY8-    | 8.0                             |                     | 30           | 3/4-20    | 9.53            | 9.1             | 0.007-0.02     |
| LNTGY10-   | 9.6                             |                     | 30           | 3/4-20    | 9.53            | 9.1             | 0.007-0.02     |

\*Thread shown imperial as standard, metric available, please specify diameter and pitch  
 # For the full range of nominal diameters, see table on pages 7-7 to 7-11

# Light Duty Adjustable Anti-Backlash Nuts

**LAB & LABY  
Series**



**Associated Products**

Reli-a-Flex® couplings: page 8-6  
Linear slides: page 9-1  
Intelligent motors: page 2-2  
Plain bearings: page 12-1

All dimensions in mm  
General tolerances  $\pm 0.5$  mm  
Detailed tolerances: Please contact us  
Material: Polyacetal

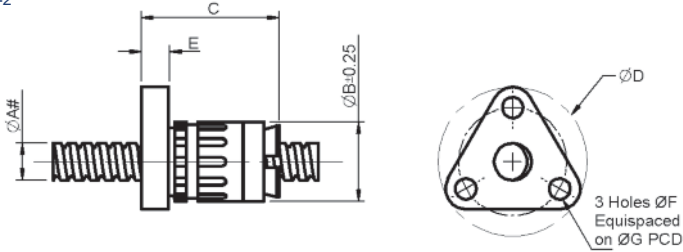

## Part number selection table - LAB series, flange mount

| Nut Series | Nominal Screw ØA# | Nut ØB | Nut Length C | Flange ØD | Flange Width E | Hole Dia ØF | Mounting Holes PCD ØG | Dynamic Load kg | Drag Torque Nm |
|------------|-------------------|--------|--------------|-----------|----------------|-------------|-----------------------|-----------------|----------------|
| LAB6-      | 6.4               | 13.5   | 25.4         | 25.4      | 4.6            | 3.6         | 19.05                 | 2.3             | 0.004-0.014    |
| LAB8-      | 8.0               | 18.8   | 48.0         | 38.1      |                |             |                       |                 |                |
| LAB10-     | 9.6               |        |              |           | 50.8           | 41.2        | 7.1                   | 5.1             | 28.58          |
| LAB11-     | 11.3              | 20.3   | 44.5         | 7.1       |                |             |                       |                 |                |
| LAB13-     | 12.7              | 22.6   |              |           | 50.8           | 44.5        | 5.1                   | 34.93           | 16.0           |
| LAB16-     | 15.9              | 26.9   |              |           |                |             |                       |                 |                |

Screw sizes 19, 22 and 24 mm available

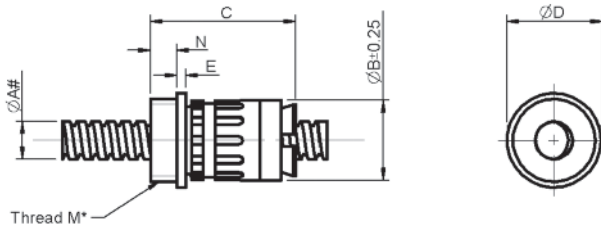

## Part number selection table - LABY series, thread mount

| Nut Series | Nominal Screw ØA# | Nut ØB | Nut Length C | Flange ØD | Flange Width E | Thread M* | Thread Length N | Dynamic Load kg | Drag Torque Nm |
|------------|-------------------|--------|--------------|-----------|----------------|-----------|-----------------|-----------------|----------------|
| LABY6-     | 6.4               | 13.5   | 33.0         | 20.3      | 3.1            | 5/8 - 18  | 4.1             | 2.3             | 0.004-0.014    |
| LABY8-     | 8.0               | 18.8   | 56.0         | 25.4      | 3.8            |           |                 |                 |                |
| LABY10-    | 9.6               |        |              |           |                |           | 59.0            | 26.4            | 2.5            |
| LABY11-    | 11.3              | 20.3   | 58.9         | 26.9      | 3.6            | 12.7      |                 |                 |                |
| LABY13-    | 12.7              | 22.6   |              |           |                |           | 58.9            | 26.9            | 3.6            |
| LABY16-    | 15.9              | 26.9   |              |           |                |           |                 |                 |                |

\*Thread shown imperial as standard, metric available, please specify diameter and pitch

# For the full range of nominal diameters, see table on pages 7-7 to 7-11



All dimensions in mm  
 General tolerances  $\pm 0.5$  mm  
 Detailed tolerances: Please contact us  
 Material: Polyacetal

**Associated Products**  
 Reli-a-Flex® couplings: page 8-6  
 Linear slides: page 9-1  
 Intelligent motors: page 2-2  
 Plain bearings: page 12-1

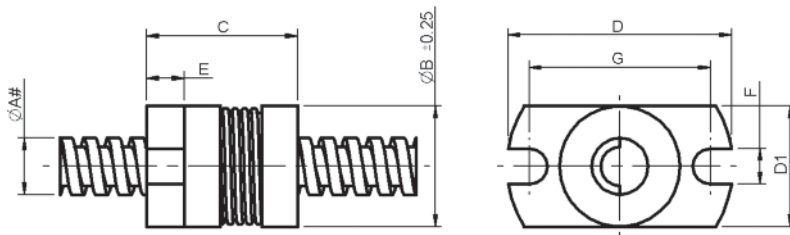

## Part number selection table - LNTBF series, flange mount

| Nut Series | Nominal Screw ØA# | Nut ØB | Nut Length C | Flange D | Flange Width E | Flange Height D1 | Slot F | Centres G | Dynamic Load kg | Drag Torque Nm |
|------------|-------------------|--------|--------------|----------|----------------|------------------|--------|-----------|-----------------|----------------|
| LNTBF3-    | 3 <sup>1</sup>    | 10.2   | 12.7         | 19.1     | 3.2            | 10.2             | 3.05   | 15.24     | 2.3             | 0.004          |
| LNTBF4-    | 4.0               |        |              |          |                |                  |        |           |                 |                |
| LNTBF5-    | 5 <sup>2</sup>    |        |              |          |                |                  |        |           |                 |                |

<sup>1</sup>LNTBF3 for Ø 3.2, 3.3 and 3.6    <sup>2</sup>LNTBF5 for Ø 5.0 and 5.6

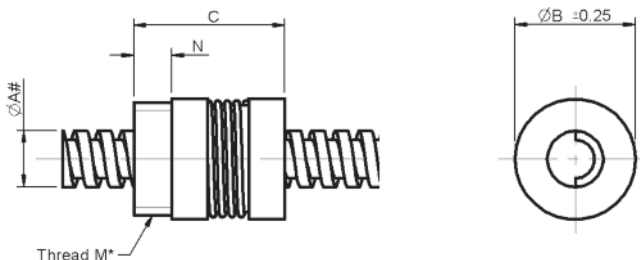

## Part number selection table - LNTBY series, thread mount

| Nut Series | Nominal Screw ØA# | Nut ØB | Nut Length C | Thread M* | Thread Length N | Dynamic Load kg | Drag Torque Nm |
|------------|-------------------|--------|--------------|-----------|-----------------|-----------------|----------------|
| LNTBY3-    | 3 <sup>1</sup>    | 10.2   | 12.7         | 3/8-24    | 3.18            | 2.3             | 0.004          |
| LNTBY4-    | 4.0               |        |              |           |                 |                 |                |
| LNTBY5-    | 5 <sup>2</sup>    |        |              |           |                 |                 |                |

<sup>1</sup>LNTBY3 for Ø 3.2, 3.3 and 3.6    <sup>2</sup>LNTBY5 for Ø 5.0 and 5.6

\*Thread shown imperial as standard, metric available, please specify diameter and pitch

# For the full range of nominal diameters, see table on pages 7-7 to 7-11



### Associated Products

Reli-a-Flex® couplings: page 8-6  
 Linear slides: page 9-1  
 Intelligent motors: page 2-2  
 Plain bearings: page 12-1

All dimensions in mm  
 General tolerances  $\pm 0.5$  mm  
 Detailed tolerances: Please contact us  
 Material: Polyacetal

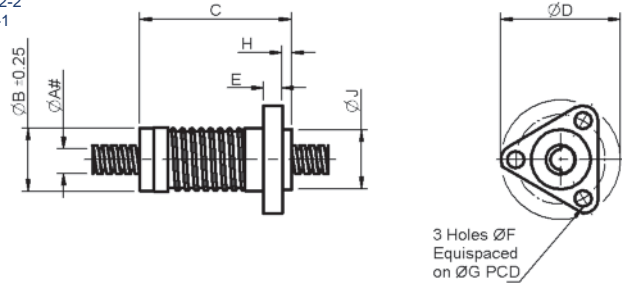

### Part number selection table - LNTBF series, flange mount

| Nut Series | Nom Screw ØA# | Nut ØB | Nut Length C | Flange ØD | Flange Width E | Hole Dia ØF | Mounting Holes PCD ØG | Hub Width H | Hub ØJ | Dynamic Load kg | Drag Torque Nm |
|------------|---------------|--------|--------------|-----------|----------------|-------------|-----------------------|-------------|--------|-----------------|----------------|
| LNTBF6-    | 6.4           | 13.2   | 28           | 25.4      | 4.0            | 3.63        | 19.1                  | 2.00        | 12.7   | 4.5             | 0.004-0.014    |
| LNTBF8-    | 8.0           | 20.3   | 46           | 38.1      | 5.1            | 5.08        | 28.6                  | 2.54        | 19.1   | 9.1             | 0.007-0.02     |
| LNTBF10-   | 9.6           |        |              | 41.2      | 5.7            |             |                       |             |        |                 |                |
| LNTBF11-   | 11.3          | 22.9   |              |           |                |             |                       |             |        |                 |                |

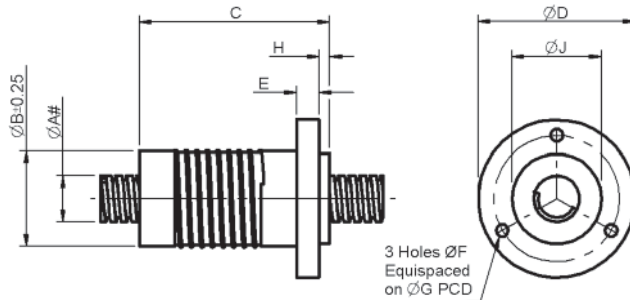

### Part number selection table - LNTBF series, flange mount

| Nut Series | Nom Screw ØA# | Nut ØB | Nut Length C | Flange ØD | Flange Width E | Hole Dia ØF | Mounting Holes PCD ØG | Hub Width H | Hub ØJ | Dynamic Load kg | Drag Torque Nm |
|------------|---------------|--------|--------------|-----------|----------------|-------------|-----------------------|-------------|--------|-----------------|----------------|
| LNTBF13-   | 12.7          | 26.9   | 54           | 44.5      | 6.4            | 5.59        | 35.71                 | 3.0         | 25.4   | 45.5            | 0.014-0.04     |
| LNTBF16-   | 15.9          | 34.9   | 59           | 54.1      | 7.0            |             | 44.45                 | 2.5         | 31.8   | 56.8            |                |
| LNTBF19-   | 19.1          | 39.6   | 67           | 60.5      | 7.9            |             | 50.80                 |             | 38.1   | 68.2            | 0.02-0.05      |

Screw sizes 22 and 24 mm available

# For the full range of nominal diameters, see table on pages 7-7 to 7-11

Leadscrew & Nut Assemblies



All dimensions in mm  
 General tolerances  $\pm 0.5$  mm  
 Detailed tolerances: Please contact us  
 Material: Polyacetal

**Associated Products**  
 Reli-a-Flex® couplings: page 8-6  
 Linear slides: page 9-1  
 Intelligent motors: page 2-2  
 Plain bearings: page 12-1

Leadscrew &  
Nut Assemblies

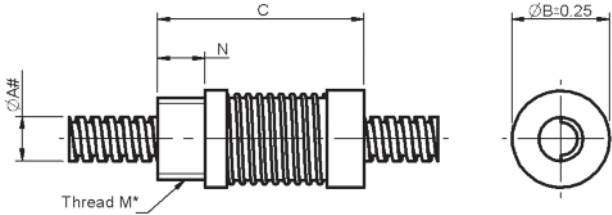

### Part number selection table - LNTBY series, thread mount

| Nut Series | Nominal Screw ØA# | Nut ØB | Nut Length C | Thread M*  | Thread Length N | Dynamic Load kg | Drag Torque Nm |
|------------|-------------------|--------|--------------|------------|-----------------|-----------------|----------------|
| LNTBY6-    | 6.4               | 13.2   | 28           | 7/16 - 20  | 6.4             | 4.5             | 0.004-0.014    |
| LNTBY8-    | 8.0               | 20.3   | 45           | 3/4 - 20   | 9.5             | 9.1             | 0.007-0.02     |
| LNTBY10-   | 9.6               |        |              |            |                 | 13.6            |                |
| LNTBY11-   | 11.3              | 22.9   | 46           | 13/16 - 16 |                 | 45.5            | 0.014-0.04     |
| LNTBY13-   | 12.7              | 26.9   | 54           | 15/16 - 16 |                 | 56.8            |                |
| LNTBY16-   | 15.9              | 34.9   | 59           | 1 1/8 - 16 |                 | 12.7            | 68.2           |
| LNTBY19-   | 19.1              | 39.6   | 67           | 1 3/8 - 16 |                 |                 |                |

\*Thread shown imperial as standard, metric available, please specify diameter and pitch  
 Screw sizes 22 and 24 mm available

# For the full range of nominal diameters, see table on [pages 7-7 to 7-11](#)





**Associated Products**  
 Reli-a-Flex® couplings: page 8-6  
 Linear slides: page 9-1  
 Intelligent motors: page 2-2  
 Plain bearings: page 12-1

All dimensions in mm  
 General tolerances  $\pm 0.5$  mm  
 Detailed tolerances: Please contact us  
 Material: Polyacetal

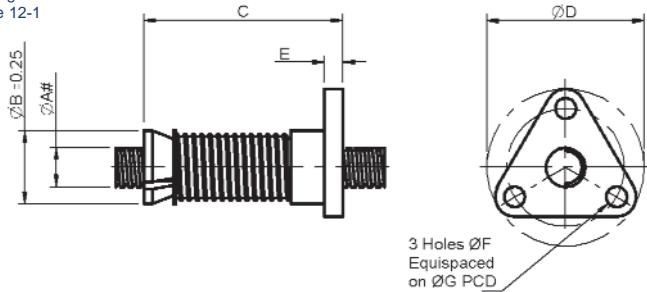

**Part number selection table - LAF series, flange mount**

| Nut Series | Nominal Screw ØA# | Nut ØB | Nut Length C | Flange ØD | Flange Width E | Hole Dia ØF | Mounting Holes PCD ØG | Dynamic Load kg | Drag Torque Nm |
|------------|-------------------|--------|--------------|-----------|----------------|-------------|-----------------------|-----------------|----------------|
| LAF6-      | 6.4               | 12.7   | 26           | 25.4      | 4.6            | 3.6         | 19.1                  | 2.3             | 0.004-0.02     |
| LAF8-      | 8.0               | 17.8   | 48           | 38.1      |                | 5.1         | 28.6                  | 5               | 0.007-0.03     |
| LAF10-     | 9.6               |        |              |           |                |             |                       | 7               | 0.014-0.04     |
| LAF11-     | 11.3              | 20.3   | 51           | 41.2      | 6.6            |             |                       | 31.8            | 11             |
| LAF13-     | 12.7              | 22.6   |              | 44.5      |                | 34.9        | 16                    | 0.028-0.055     |                |
| LAF16-     | 15.9              | 26.9   |              | 44.5      |                | 34.9        | 16                    | 0.028-0.055     |                |

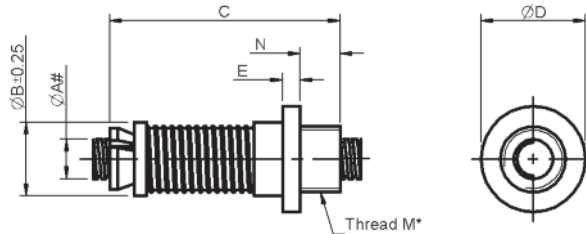

**Part number selection table - LAFY series, thread mount**

| Nut Series | Nominal Screw ØA# | Nut ØB | Nut Length C | Flange ØD | Flange Width E | Thread M*  | Thread Length N | Dynamic Load kg | Drag Torque Nm |
|------------|-------------------|--------|--------------|-----------|----------------|------------|-----------------|-----------------|----------------|
| LAFY6-     | 6.4               | 12.7   | 33           | 20.3      | 5.6            | 5/8 - 18   | 4.1             | 2.3             | 0.004-0.02     |
| LAFY8-     | 8.0               | 17.8   | 56           | 25.4      | 4.3            |            | 9.7             | 5.0             | 0.007-0.03     |
| LAFY10-    | 9.6               |        |              |           | 3.1            |            |                 | 7.0             | 0.014-0.04     |
| LAFY11-    | 11.3              | 20.3   | 59           | 25.9      | 3.8            | 15/16 - 16 |                 | 11.0            | 0.02-0.05      |
| LAFY13-    | 12.7              | 22.6   |              | 26.9      |                |            | 12.7            | 16.0            | 0.028-0.055    |
| LAFY16-    | 15.9              | 26.9   |              | 61        |                |            | 26.9            | 3.8             | 12.7           |

\*Thread shown imperial as standard, metric available, please specify diameter and pitch

# For the full range of nominal diameters, see table on pages 7-7 to 7-11



All dimensions in mm  
 General tolerances  $\pm 0.5$  mm  
 Detailed tolerances: Please contact us  
 Material: Polyacetal

**Associated Products**  
 Reli-a-Flex® couplings: page 8-6  
 Linear slides: page 9-1  
 Intelligent motors: page 2-2  
 Plain bearings: page 12-1

Leadscrew & Nut Assemblies

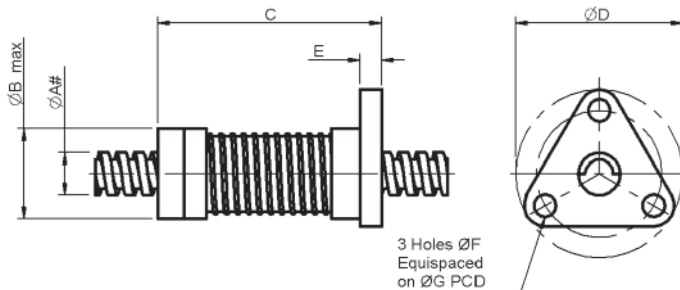

**Part number selection table - LAK series, flange mount**

| Nut Series | Nominal Screw ØA# | Nut ØB | Nut Length C | Flange ØD | Flange Width E | Hole Dia ØF | Mounting Holes PCD ØG | Dynamic Load kg | Drag Torque Nm |
|------------|-------------------|--------|--------------|-----------|----------------|-------------|-----------------------|-----------------|----------------|
| LAK8-      | 8.0               | 20.3   | 50.8         | 38.1      | 4.8            | 5.08        | 28.58                 | 10              | 0.007-0.02     |
| LAK10-     | 9.6               |        |              |           |                |             |                       |                 |                |

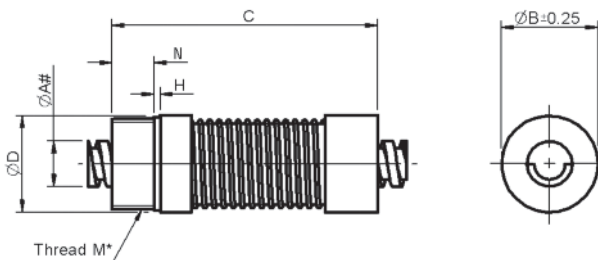

**Part number selection table - LAKY series, thread mount**

| Nut Series | Nominal Screw ØA# | Nut ØB | Flange ØD | Nut Length C | Thread M* | Thread Length N | Hub Width H | Dynamic Load kg | Drag Torque Nm |
|------------|-------------------|--------|-----------|--------------|-----------|-----------------|-------------|-----------------|----------------|
| LAKY8-     | 8.0               | 20.3   | 19.1      | 55.9         | 3/4-20    | 8.9             | 1.27        | 10              | 0.007-0.02     |
| LAKY10-    | 9.6               |        |           |              |           |                 |             |                 |                |

\*Thread shown imperial as standard, metric available, please specify diameter and pitch  
 # For the full range of nominal diameters, see table on pages 7-7 to 7-11



**Associated Products**  
 Reli-a-Flex® couplings: page 8-6  
 Linear slides: page 9-1  
 Intelligent motors: page 2-2  
 Plain bearings: page 12-1

All dimensions in mm  
 General tolerances  $\pm 0.5$  mm  
 Detailed tolerances: Please contact us  
 Material: Polyacetal

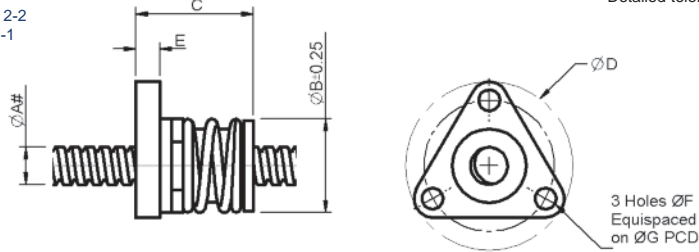

## Part number selection table - LWD series, flange mount

| Nut Series | Nominal Screw ØA# | Nut ØB | Nut Length C | Flange ØD | Flange Width E | Hole Dia ØF | Mounting Holes PCD ØG | Dynamic Load kg | Drag Torque Nm |
|------------|-------------------|--------|--------------|-----------|----------------|-------------|-----------------------|-----------------|----------------|
| LWD5-      | 5.0               | 16     | 26.6         | 28.6      | 4.10           | 3.7         | 22.2                  | 4.5             | 0.03           |
| LWD5.6-    | 5.6               |        |              |           |                |             |                       |                 |                |
| LWD6-      | 6.4               |        |              |           |                |             |                       |                 |                |
| LWD8-      | 8.0               | 19     | 33.5         | 38.1      | 5.10           | 5.1         | 28.6                  | 11.3            | 0.04           |
| LWD10-     | 9.6               |        |              |           |                |             |                       |                 |                |
| LWD11-     | 11.3              | 25.4   | 52.8         | 44.5      | 6.35           | 5.6         | 35.7                  | 34.0            | 0.06           |
| LWD13-     | 12.7              |        |              |           |                |             |                       |                 |                |

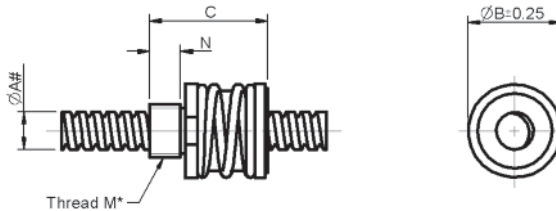

## Part number selection table - LWDY series, thread mount

| Nut Series | Nominal Screw ØA# | Nut ØB | Nut Length C | Thread M*  | Thread Length N | Dynamic Load kg | Drag Torque Nm |
|------------|-------------------|--------|--------------|------------|-----------------|-----------------|----------------|
| LWDY5-     | 5.0               | 16     | 26.6         | 9/16 - 18  | 6.1             | 4.5             | 0.03           |
| LWDY5.6-   | 5.6               |        |              |            |                 |                 |                |
| LWDY6-     | 6.4               |        |              |            |                 |                 |                |
| LWDY8-     | 8.0               | 19     | 33.5         | 5/8 - 18   | 8.1             | 11.3            | 0.04           |
| LWDY10-    | 9.6               |        |              |            |                 |                 |                |
| LWDY11-    | 11.3              | 25.4   | 52.8         | 15/16 - 16 | 12.7            | 34.0            | 0.06           |
| LWDY13-    | 12.7              |        |              |            |                 |                 |                |

\*Thread shown imperial as standard, metric available, please specify diameter and pitch  
 # For the full range of nominal diameters, see table on pages 7-7 to 7-11

Leadscrew & Nut Assemblies



All dimensions in mm  
 General tolerances  $\pm 0.5$  mm  
 Detailed tolerances: Please contact us  
 Material: Polyacetal

**Associated Products**  
 Reli-a-Flex® couplings: page 8-6  
 Linear slides: page 9-1  
 Intelligent motors: page 2-2  
 Plain bearings: page 12-1

Leadscrew & Nut Assemblies

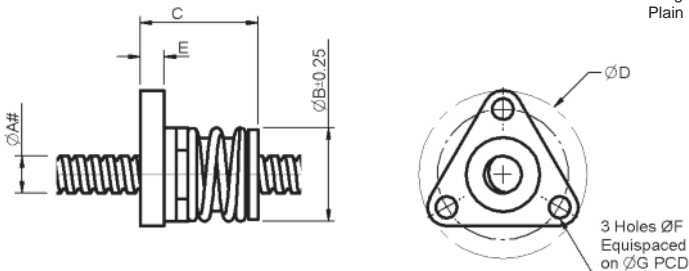

### Part number selection table - LCM series, flange mount

| Nut Series | Nominal Screw ØA# | Nut ØB | Nut Length C | Flange ØD | Flange Width E | Hole Dia ØF | Mounting Holes PCD ØG | Dynamic Load kg | Drag Torque Nm |
|------------|-------------------|--------|--------------|-----------|----------------|-------------|-----------------------|-----------------|----------------|
| LCM5-      | 5                 | 16     | 26.6         | 28.6      | 4.1            | 3.7         | 22.2                  | 2.3             | 0.03           |
| LCM5.6-    | 5.6               |        |              |           |                |             |                       |                 |                |
| LCM6-      | 6.4               |        |              |           |                |             |                       |                 |                |
| LCM8-      | 8.0               | 19     | 33.5         | 38.1      | 5.1            | 5.1         | 28.6                  | 3.6             | 0.04           |
| LCM10-     | 9.6               |        |              |           |                |             |                       |                 |                |

The LCM5, 5.6 and 6 nuts are available with a pilot hub,  $\text{Ø}15.9$  mm x 2.04 wide  
 The LCM8 and 10 nuts are available with a pilot hub,  $\text{Ø}19.1$  mm x 3.05 wide, please contact us

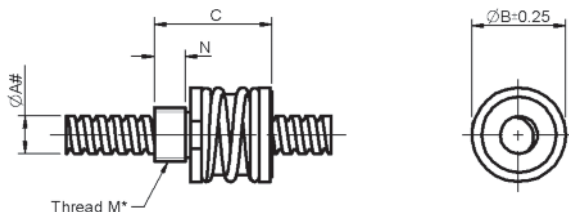

### Part number selection table - LCMY series, thread mount

| Nut Series | Nominal Screw ØA# | Nut ØB | Nut Length C | Thread M* | Thread Length N | Dynamic Load kg | Drag Torque Nm |
|------------|-------------------|--------|--------------|-----------|-----------------|-----------------|----------------|
| LCMY5-     | 5.0               | 16     | 26.6         | 9/16 - 18 | 6.1             | 2.3             | 0.03           |
| LCMY5.6-   | 5.6               |        |              |           |                 |                 |                |
| LCMY6-     | 6.4               |        |              |           |                 |                 |                |
| LCMY8-     | 8.0               | 19     | 33.5         | 5/8 - 18  | 8.1             | 3.6             | 0.04           |
| LCMY10-    | 9.6               |        |              |           |                 |                 |                |

\*Thread shown imperial as standard, metric available, please specify diameter and pitch  
 # For the full range of nominal diameters, see table on pages 7-7 to 7-11



**Associated Products**  
 Reli-a-Flex® couplings: page 8-6  
 Linear slides: page 9-1  
 Intelligent motors: page 2-2  
 Plain bearings: page 12-1

All dimensions in mm  
 General tolerances  $\pm 0.5$  mm  
 Detailed tolerances: Please contact us  
 Material: Polyacetal with bronze  
 anti-backlash mechanism

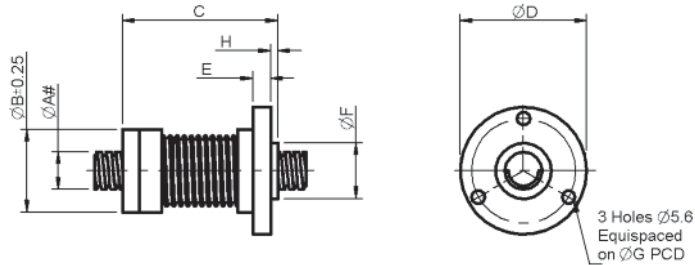

### Part number selection table - LAX series, flange mount

| Nut Series | Nominal Screw $\varnothing A\#$ | Nut $\varnothing B$ | Nut Length C | Flange $\varnothing D$ | Flange Width E | Mounting Holes PCD $\varnothing G$ | Hub Length H | Hub $\varnothing F$ | Dynamic Load kg | Drag Torque Nm  |
|------------|---------------------------------|---------------------|--------------|------------------------|----------------|------------------------------------|--------------|---------------------|-----------------|-----------------|
| LAX13-     | 12.7                            | 28.5                | 59           | 44.5                   | 5.9            | 35.71                              | 3.1          | 23.62               | 68              | 0.014-0.02-0.05 |
| LAX16-     | 15.9                            | 35.1                | 66           | 53.0                   | 7.1            | 44.45                              | --           | --                  | 113             |                 |
| LAX19-     | 19.1                            | 41.2                | 71           | 60.5                   | 7.9            | 50.80                              | --           | --                  | 159             |                 |

Screw size 22 available

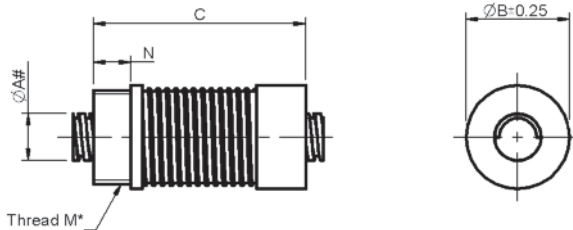

### Part number selection table - LAXY series, thread mount

| Nut Series | Nominal Screw $\varnothing A\#$ | Nut $\varnothing B$ | Nut Length C | Thread M* | Thread Length N | Dynamic Load kg | Drag Torque Nm |
|------------|---------------------------------|---------------------|--------------|-----------|-----------------|-----------------|----------------|
| LAXY13-    | 12.7                            | 28.5                | 64           | 15/16-16  | 12.7            | 68              | 0.014-0.04     |
| LAXY16-    | 15.9                            | 35.1                | 72           | 1 1/4-16  |                 | 113             |                |
| LAXY19-    | 19.1                            | 41.2                | 79           | 1 3/8-16  |                 | 159             | 0.02-0.05      |

\*Thread shown imperial as standard, metric available, please specify diameter and pitch  
 Screw size 22 available

# For the full range of nominal diameters, see table on pages 7-7 to 7-11



## Modified, custom and multi-functional nuts

In addition to the standard nut types, custom configurations are available as well as simple modifications such as different mounting hole patterns or mounting threads, small dimensional changes or special materials.

Custom nut designs can offer multi-functionality, eliminating additional components, simplifying product manufacture, saving space and reducing cost. Multi-functional nuts can be produced using custom moulds and special machining to integrate components into the nut, such as guide bushings, carriages, timing pulleys, gears, syringe components, sensor mounts and flags, encoder features, clamps and many other complementary elements. In addition, custom designed nuts can offer quick release mounts, partial thread engagement, half nut construction or alternative shapes and geometries.

Special materials are available to extend the performance of the assemblies. We offer a range of Kerkite® composite polymers. Each member of the Kerkite® family is compounded with lubricants, reinforcements and thermoplastic polymers formulated to provide optimum performance in its target conditions and applications. In addition to the Kerkite® composite polymers, materials such as PEEK, polyester, Torlon, Vespel, PVDF, UHMW, Ertalyte® are available. Materials can be chosen for extreme temperature, chemical compatibility, autoclaving, agency approvals, special loadings and many other specific requirements.

Custom geometries and materials can be combined for a wide variety of product application requirements. Small quantities of custom nuts can be machined individually to suit specific requirements, alternatively large quantities can be moulded for reduced costs.

To achieve the most effective nut design we consider a combination of tolerancing and geometric shape of the nut. Tighter tolerances can be achieved by designing in geometric features to control important diameters, for example use of a ribbed feature on a bearing location diameter will reduce the need for tighter manufacturing tolerances.



## End modifications

Leadscrews are supplied with cut ends as standard. Alternatively we supply a selection of standard machined ends suitable for interfacing with a range of associated products including; bearings, circlips, couplings, pulleys and gears.

End **A** - Ball bearing : page 7-28

End **D** - Twin bearings & coupling : page 7-31

End **B** - Ball bearing & circlip : page 7-29

End **E** - Ball bearing & pulley : page 7-32

End **C** - Ball bearing & coupling : page 7-30

End **F** - Ball bearing & gear : page 7-33

## Ordering your modified end detail

To order a leadscrew with machined ends, use the ordering example below. If only one end is to be machined leave the 2nd end machining suffix blank.

Example part no. - **LPX10 - M050 - 350MM - C A**

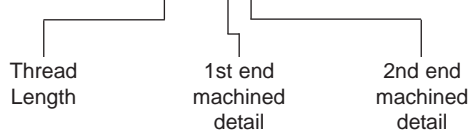

## Custom machined leadscrew ends

We are also able to supply custom machined ends to drawing; the drawing and specification details required and tolerances available are provided on page 7-34 and 7-35. Please contact us to discuss your requirements.

## Associated products

| Leadscrew Diameter | Standard Bearing P/No. <sup>1</sup> | Standard Circlip P/No. | Standard Coupling P/No. <sup>2</sup> |
|--------------------|-------------------------------------|------------------------|--------------------------------------|
| 6                  | B1-104-S-P4                         | D1400-0040-SS          | RCLA13C-**-*                         |
| 10                 | B1-106-S-P4                         | D1400-0060-SS          | RCLA16C-**-*                         |
| 11                 | B1-108-S-P4                         | D1400-0080-SS          | RCLA20C-**-*                         |
| 13                 | B1-108-S-P4                         | D1400-0080-SS          | RCLA20C-**-*                         |

<sup>1</sup> Bearings for low to medium loads, see page 12-2. For high loads please contact us.

<sup>2</sup> Add bore diameters to complete part number, see pages 8-10, 8-12, 8-14

| Leadscrew Diameter | Standard Pulley P/No. <sup>3</sup> | Standard Shim P/No. | Standard Gear P/No. <sup>4</sup> |
|--------------------|------------------------------------|---------------------|----------------------------------|
| 6                  | TPMP25 F6-**                       | SS1-104             | P**S1B4 F4A**                    |
| 10                 | TPMP25 F6-**                       | SS1-108             | P**S1B6 F4A**                    |
| 11                 | TPMP25 F6-**                       | SS1-112             | P**S1B8 F6A**                    |
| 13                 | TPMP25 F6-**                       | SS1-112             | P**S1B8 F6A**                    |

<sup>3</sup> Add required number of teeth to complete part number, see page 10-3

<sup>4</sup> Add gear module and required number of teeth to complete part number, see from page 4-1

For all other accessories shown above, please refer to sections 12 and 13.



All dimensions in mm  
General tolerances  $\pm 0.13$  mm

## Ball bearing journal, End A

Leadscrew & Nut Assemblies

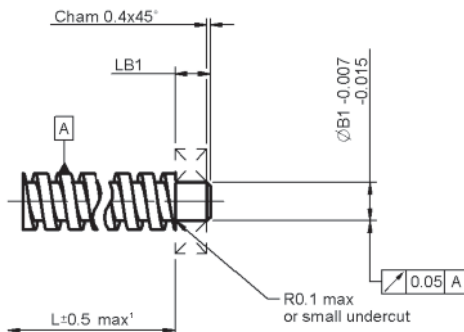

## Drawing dimension table

| Leadscrew Diameter | Screw Diameter | Journal      |            |
|--------------------|----------------|--------------|------------|
|                    |                | Diameter ØB1 | Length LB1 |
| 6                  | 6.35           | 4            | 4.5        |
| 10                 | 9.53           | 6            | 5.5        |
| 11                 | 11.11          | 8            | 6.5        |
| 13                 | 12.70          | 8            | 6.5        |

¹ L tolerance is dependent on the length of the leadscrew - see page 7-35 for actual tolerance.



### **i** Information

- Ordering instructions - see page 7-3 and 7-27
- Associated products - see page 7-27
- Custom end machining - see page 7-34 and 7-35
- Technical information - see pages T7-1 to T7-5





All dimensions in mm  
General tolerances  $\pm 0.13$  mm

## Ball bearing journal with circlip groove, End B

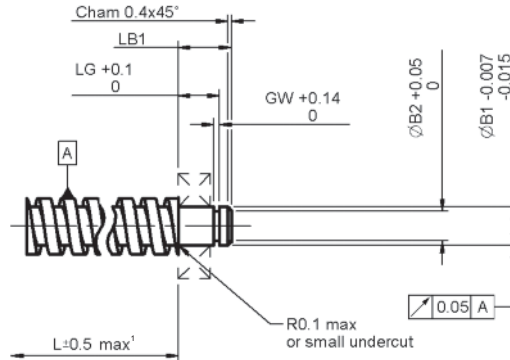

## Drawing dimension table

| Leadscrew Diameter | Screw Diameter | Journal          |           | Groove           |          | Length |
|--------------------|----------------|------------------|-----------|------------------|----------|--------|
|                    |                | Dia $\text{ØB1}$ | Length LG | Dia $\text{ØB2}$ | Width GW |        |
| 6                  | 6.35           | 4                | 4.8       | 3.75             | 0.5      | 7.0    |
| 10                 | 9.53           | 6                | 6.1       | 5.65             | 0.8      | 8.5    |
| 11                 | 11.11          | 8                | 7.2       | 7.54             | 0.9      | 9.5    |
| 13                 | 12.70          | 8                | 7.2       | 7.54             | 0.9      | 9.5    |

<sup>1</sup> L tolerance is dependent on the length of the leadscrew - see page 7-35 for actual tolerance.

### **i** Information

- Ordering instructions - see page 7-3 and 7-27
- Associated products - see page 7-27
- Custom end machining - see page 7-34 and 7-35
- Technical information - see pages T7-1 to T7-5





All dimensions in mm  
General tolerances  $\pm 0.13$  mm

## Ball bearing journal for coupling, End C

Leadscrew & Nut Assemblies

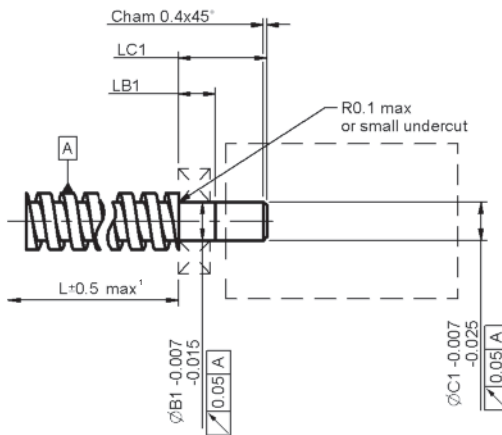

## Drawing dimension table

| Leadscrew Diameter | Screw Diameter | Journal |            | Coupling Diameter ØC1 | Length LC1 |
|--------------------|----------------|---------|------------|-----------------------|------------|
|                    |                | Dia ØB1 | Length LB1 |                       |            |
| 6                  | 6.35           | 4       | 4.5        | 4                     | 14.0       |
| 10                 | 9.53           | 6       | 5.5        | 6                     | 15.0       |
| 11                 | 11.11          | 8       | 6.5        | 8                     | 20.5       |
| 13                 | 12.70          | 8       | 6.5        | 8                     | 20.5       |

<sup>1</sup> L tolerance is dependent on the length of the leadscrew - see page 7-35 for actual tolerance.



### **i** Information

- Ordering instructions - see page 7-3 and 7-27
- Associated products - see page 7-27
- Custom end machining - see page 7-34 and 7-35
- Technical information - see pages T7-1 to T7-5

All dimensions in mm  
General tolerances  $\pm 0.13$  mm

## Twin ball bearing journal for coupling, End D

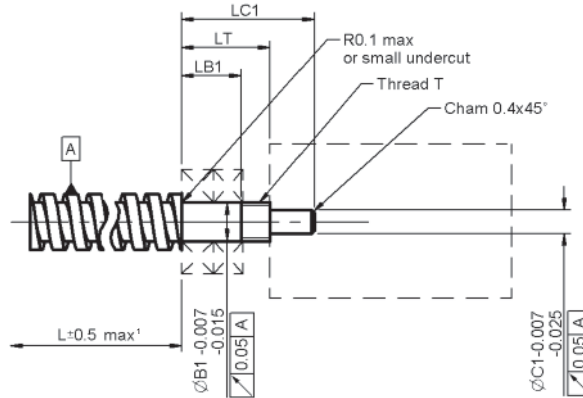

## Drawing dimension table

| Leadscrew Diameter | Screw Dia | Journal |            | Thread      |    | Coupling |            |
|--------------------|-----------|---------|------------|-------------|----|----------|------------|
|                    |           | Dia ØB1 | Length LB1 | Distance LT | T  | Dia ØC1  | Length LC1 |
| 6                  | 6.35      | 4       | 7.5        | 11.2        | M4 | 3        | 17.5       |
| 10                 | 9.53      | 6       | 9.5        | 15.0        | M6 | 4        | 22.5       |
| 11                 | 11.11     | 8       | 11.5       | 18.5        | M8 | 6        | 28.5       |
| 13                 | 12.70     | 8       | 11.5       | 18.5        | M8 | 6        | 28.5       |

¹ L tolerance is dependent on the length of the leadscrew - see page 7-35 for actual tolerance.



### **i** Information

- Ordering instructions - see page 7-3 and 7-27
- Associated products - see page 7-27
- Custom end machining - see page 7-34 and 7-35
- Technical information - see pages T7-1 to T7-5



All dimensions in mm  
General tolerances  $\pm 0.13$  mm

## Ball bearing journal for drive pulley, End E

Leadscrew & Nut Assemblies

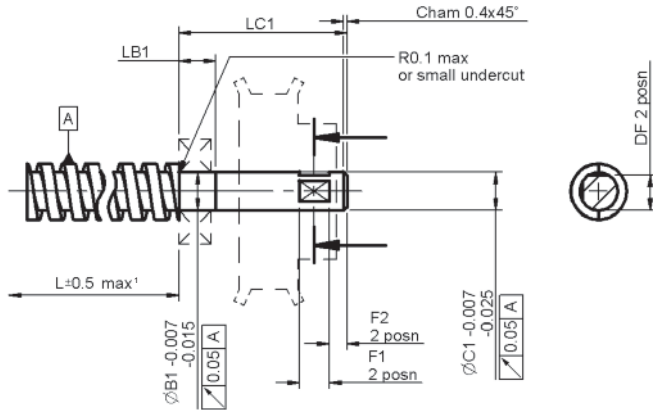

### Drawing dimension table

| Leadscrew Diameter | Screw Dia | Journal |            | Pulley Dia ØC1 | Length LC1 | Flats    |           |             |
|--------------------|-----------|---------|------------|----------------|------------|----------|-----------|-------------|
|                    |           | Dia ØB1 | Length LB1 |                |            | Width F1 | Length F2 | Distance DF |
| 6                  | 6.35      | 4       | 4.5        | 4              | 27.5       | 4        | 3         | 3.5         |
| 10                 | 9.53      | 6       | 5.5        | 6              | 28.5       | 5        | 3         | 5.5         |
| 11                 | 11.11     | 8       | 6.5        | 8              | 29.5       | 6        | 3         | 7.5         |
| 13                 | 12.70     | 8       | 6.5        | 8              | 29.5       | 6        | 3         | 7.5         |

<sup>1</sup> L tolerance is dependent on the length of the leadscrew - see page 7-35 for actual tolerance.



### Information

- Ordering instructions - see page 7-3 and 7-27
- Associated products - see page 7-27
- Custom end machining - see page 7-34 and 7-35
- Technical information - see pages T7-1 to T7-5

All dimensions in mm  
General tolerances  $\pm 0.13$  mm

## Ball bearing journal for drive gear, End F

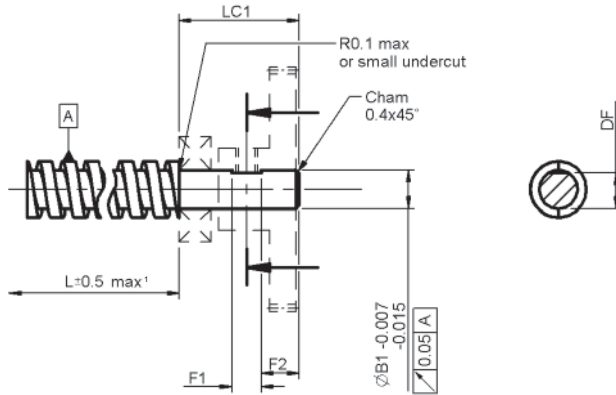

### Drawing dimension table

| Leadscrew Diameter | Screw Dia | Journal              |            | Flat Width F1 | Length F2 | Flat Distance DF |
|--------------------|-----------|----------------------|------------|---------------|-----------|------------------|
|                    |           | Dia $\varnothing B1$ | Length LC1 |               |           |                  |
| 6                  | 6.35      | 4                    | 17.5       | 4             | 5.0       | 3.5              |
| 10                 | 9.53      | 6                    | 20.5       | 5             | 6.5       | 5.5              |
| 11                 | 11.11     | 8                    | 21.5       | 6             | 6.0       | 7.5              |
| 13                 | 12.70     | 8                    | 21.5       | 6             | 6.0       | 7.5              |

<sup>1</sup> L tolerance is dependent on the length of the leadscrew - see page 7-35 for actual tolerance.



### **i** Information

- Ordering instructions - see page 7-3 and 7-27
- Associated products - see page 7-27
- Custom end machining - see page 7-34 and 7-35
- Technical information - see pages T7-1 to T7-5



# Custom Leadscrew End Machining

All dimensions in mm

## Required drawing details

To order a leadscrew with custom machined ends please provide the following drawing information:

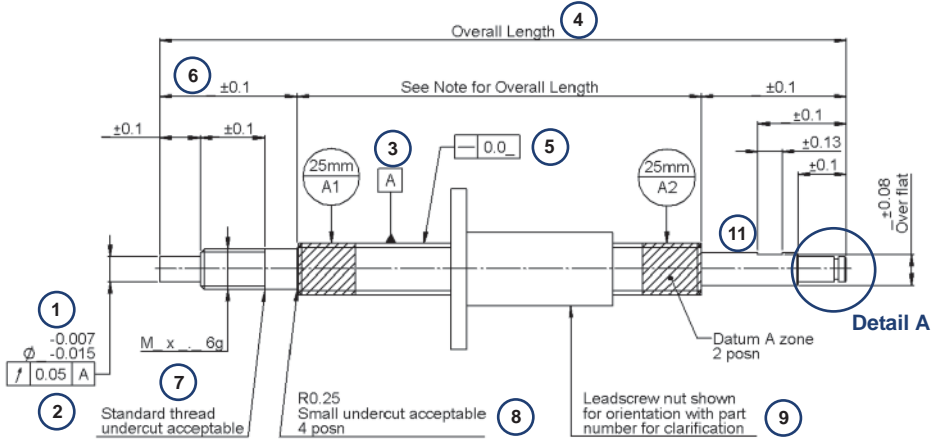

## Drawing tolerances

General manufacturing tolerance ISO2768-mK.  
 If a shoulder is required for bearing location at the extremities of the leadscrew thread then a bearing journal diameter of less than the leadscrew thread root should be selected.  
 All journals that are larger than the thread root of the leadscrew will have the scroll of the leadscrew thread root evident.

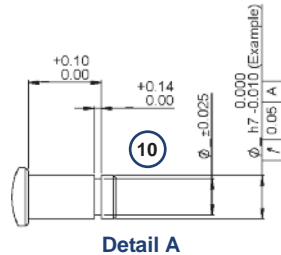

## Further machined features

- Cross holes: Symmetry 0.25mm  
Hole position 0.1mm  
Hole diameter 0.025mm
- Bored end holes; drilled depth 0.5mm
- Bored hole depth 0.25mm
- For bored holes up to a length of 4 x the diameter a tolerance of 0.013mm can be achieved.
- For bored holes over a length of 4 x the diameter a tolerance of 0.025mm can be achieved.
- Width of keyways 0.025mm.



- 1 Machined journal recommended tolerances**  
For journals over  $\text{Ø}3.2$  mm and under 19 mm long and for use with Reliance bearings and gears for the optimum assembly and function we recommend a tolerance of or greater than:  
-0.005  
-0.017  
For journals under  $\text{Ø}3.2$  mm and over 19mm long and for use with Reliance couplings, pulleys etc. we recommend a diameter tolerance of or greater than:  
-0.005  
-0.027  
For an additional charge Reliance can provide a minimum journal tolerance of 0.008 mm. This is dependant upon the journal length, geometry, diameter and material.
- 2 Runout**  
To geometrically control journals and end machined features, Reliance measure runout as opposed to concentricity. The standard runout tolerance is 0.05 mm referenced to the datum A zones.  
0.035 mm is available for precision journals of lengths less than 25 mm.  
0.025 mm is achievable for journals less than 13 mm.
- 3 Datum**  
The leadscrews are manufactured using a cold rolling process therefore a datum is located on the outside diameter of the leadscrew thread. The datum is specified at the marked datum 1 zones which are as standard 25 mm from each end of the leadscrew thread.
- 4 Overall length and leadscrew thread length**  
Tolerancing for lengths:  
From 25.4 mm to 228 mm tolerance  $\pm 0.25$   
Over 228 mm to 812 mm tolerance  $\pm 0.5$   
Over 812 mm tolerance  $\pm 1.0$
- 5 Straightness**  
0.025 mm per 100mm of length.  
For screws less than 300 mm long the default value is 0.075 mm.
- 6 Journal length**  
The tolerance of  $\pm 0.1$  or greater should be used in general. For shorter journals of less than 25 mm  $\pm 0.06$  can be achieved.
- 7 Secondary threads**  
Include the size and pitch of the required thread e.g. M6x1, and include the thread fit tolerance i.e. 6g. A standard thread undercut may be used at the discretion of Reliance, the undercut will be 1-3 x thread pitches wide and to the thread root diameter.
- 8 Corner radius**  
A small manufacturing undercut may be required to achieve the required corner radius, dependant upon the manufacturing method used. In general this will be for a corner radius of 0.25 mm or smaller.
- 9 Leadscrew nut**  
Reliance strongly recommends that wherever possible the leadscrew nut is included on the leadscrew drawing and they are supplied as an assembly. This ensures the fit between leadscrew nut and leadscrew is completely controlled. The orientation of the nut should be defined.
- 10 Circlip grooves**  
Circlip grooves can be achieved when manufactured in line with the tolerances shown above.
- 11 Flats**  
If the flat is for location purposes then we recommend specification of a flatness of 0.03 mm across the face.



## Introduction

Reliance's range of Leadscrew Linear Slides and ScrewRail™ assemblies provide a further level of component integration as opposed to a standalone leadscrew and nut assembly. These higher level assemblies combine leadscrew and nut assemblies with additional system elements such as bearings, carriages and housings, helping to simplify the design and manufacture of motion systems.



Leadscrew linear slide



ScrewRail™ assembly

## Leadscrew linear slide

The leadscrew driven slide offers reliable, continuous linear speed whilst maintaining accurate positioning. It is not limited by critical screw speed, allowing high rpm and linear speeds. It has a unique, compact profile that provides exceptional torsional stiffness and stability for its size and weight.

The unit is a single piece aluminium extrusion which houses a stainless steel leadscrew together with an integrated pre-loaded nut and carriage. It is designed for connection to a motor drive mechanism and is provided with appropriate leadscrew machined end(s) and bearing(s) for connection via a coupling, a series of pulleys or a geared system.

It is a fully supported leadscrew actuator, which enables longer travel, higher speeds and higher loads, compared to a standard leadscrew and nut assembly arrangement, without the need for additional support elements. The integral mounting base provides support over the entire length.

The Leadscrew Linear Slide provides linear actuation with 0.0006 mm/mm lead accuracy. It is offered in an extensive range of travel lengths, from 11 mm up to 1000 mm, range of diameters to support loads up to 46 kg and range of leads to provide different linear speeds. It has a double bearing design and is Teflon coated across all surfaces, giving smooth, accurate movement.

This robust, integrated unit is suitable for a variety of applications including laboratory automation equipment and industrial automation.





## ScrewRail™ assembly

Where linear motion has traditionally required separate components to handle both the drive and support/guidance the compact ScrewRail™ combines both functions in a single, coaxial component. By eliminating the need for external rail-to-screw alignment the ScrewRail™ simplifies the design, manufacture and assembly of the motion system, saving as much as 80% of the space used by a two-rail system and helping reduce component and assembly costs.

The ScrewRail™ consists of a precision rolled leadscrew, supported by sealed bearings, contained within a concentric steel guide rail, driving an integrated nut/bushing. Because all the alignment requirements are achieved within the ScrewRail™, support and positioning of the ScrewRail™ is much less critical than with traditional slide assemblies. TFE coating and self-lubricating nut/bushing materials ensure long life, without maintenance. Standard end supports are available to mount the ScrewRails™.

With lengths of up to 1200 mm and with four diameter options, the ScrewRail™ is capable of moving loads from 5 kg up to 45 kg. Two versions are available, with either plain or anti-backlash nuts.

The ScrewRail™ gives three-dimensional motion from a single unit. When mounted vertically it can be used to simultaneously lift and rotate (Z-theta motion). With one motor driving the screw and a second rotating the rail, a compact pick and place mechanism can be created.

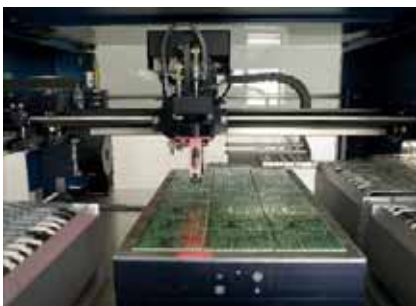

Semi-conductor pick and place robotics



Laboratory automation



All dimensions in mm

Materials:  
 Guide and carriage - Aluminium alloy TFE coated  
 Leadscrew - Stainless steel TFE coated  
 Follower nut - Polyacetal

**Associated Products**  
 Intelligent motors: page 2-2  
 Reli-a-Flex® couplings: page 8-6  
 Hardware: page 13-1

| Dimensional Tolerances |        |
|------------------------|--------|
| < L4                   | ± 0.1  |
| 4 < L ≤ 16             | ± 0.15 |
| 16 < L ≤ 63            | ± 0.2  |
| 63 < L ≤ 250           | ± 0.3  |

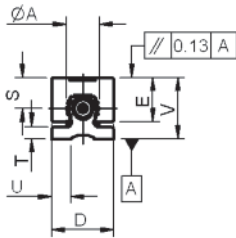
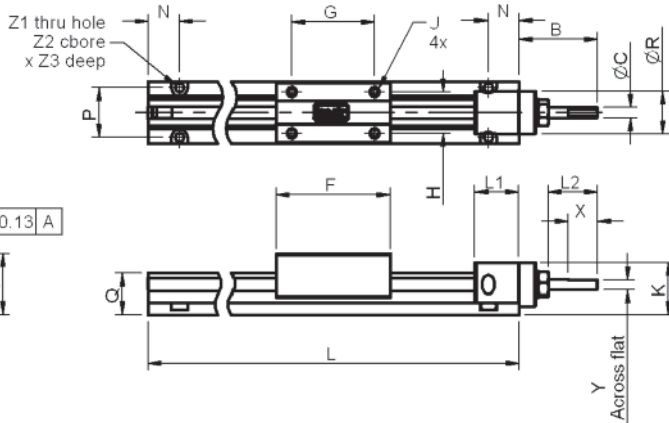

## Technical specification

Total Travel = L - L1 - F

| Series        | A<br>Nominal<br>Rail Ø | B    | ØC    | D    | E    | F  | G     | H    | J <sup>1</sup>              | K  | L1   | L2   | N     |
|---------------|------------------------|------|-------|------|------|----|-------|------|-----------------------------|----|------|------|-------|
| <b>RGLS6</b>  | 10.2                   | 21.1 | 3.175 | 19.1 | 13.5 | 36 | 25.4  | 12.7 | 4-40<br>UNC<br>4.45 deep    | 15 | 13.5 | 11.9 | 9.53  |
| <b>RGLS10</b> | 15.2                   | 31.8 | 4.762 | 28.6 | 20.1 | 51 | 38.1  | 19.1 | 6-32<br>UNC<br>6.35 deep    | 23 | 20.3 | 20.3 | 12.70 |
| <b>RGLS13</b> | 20.3                   | 38.1 | 6.350 | 40.6 | 26.9 | 69 | 44.45 | 25.4 | 10-24<br>UNC<br>9.60 deep   | 33 | 27.7 | 19.6 | 15.88 |
| <b>RGLS16</b> | 25.4                   | 44.5 | 7.938 | 50.8 | 33.5 | 83 | 57.15 | 31.8 | 1/4-20<br>UNC<br>10.80 deep | 41 | 33.0 | 33.0 | 19.05 |

<sup>1</sup>Metric mounting configuration available, please enquire

| Series        | P     | Q    | ØR   | S    | T   | U    | V    | X    | Y    | Z1  | Z2   | Z3  |
|---------------|-------|------|------|------|-----|------|------|------|------|-----|------|-----|
| <b>RGLS6</b>  | 15.24 | 12.7 | 13.2 | 9.4  | 3.8 | 5.8  | 18.5 | 9.7  | 2.92 | 2.8 | 5.1  | 2.3 |
| <b>RGLS10</b> | 22.86 | 18.8 | 20.3 | 14.0 | 5.6 | 8.9  | 27.9 | 12.7 | 4.32 | 3.6 | 6.4  | 3.3 |
| <b>RGLS13</b> | 31.75 | 25.4 | 26.4 | 18.8 | 7.6 | 13.0 | 37.3 | 17.8 | 5.59 | 5.1 | 8.4  | 4.8 |
| <b>RGLS16</b> | 38.10 | 31.8 | 33.0 | 23.4 | 9.5 | 16.3 | 46.5 | 22.4 | 7.11 | 6.6 | 12.7 | 5.6 |

Leadscrew & Nut Assemblies



## Standard product sizes

|         | Series (Screw Size)  |     |     |     |        |     |     |     |        |     |     |     |        |     |     |     |     |     |     |     |
|---------|----------------------|-----|-----|-----|--------|-----|-----|-----|--------|-----|-----|-----|--------|-----|-----|-----|-----|-----|-----|-----|
|         | RGLS6                |     |     |     | RGLS10 |     |     |     | RGLS13 |     |     |     | RGLS16 |     |     |     |     |     |     |     |
|         | Guide Length L ±1 mm |     |     |     |        |     |     |     |        |     |     |     |        |     |     |     |     |     |     |     |
| Lead mm | 152                  | 203 | 254 | 305 | 254    | 305 | 381 | 457 | 610    | 914 | 254 | 305 | 457    | 610 | 914 | 254 | 305 | 457 | 610 | 914 |
| 2.54    | ★                    | ★   | ★   | ★   | ★      | ★   | ★   | ★   | ★      |     |     | ★   |        |     |     |     | ★   |     |     |     |
| 5.08    | ★                    | ★   | ★   | ★   | ★      | ★   | ★   | ★   | ★      |     |     | ★   |        |     |     |     | ★   |     |     |     |
| 12.7    | ★                    | ★   | ★   | ★   |        | ★   | ★   | ★   | ★      |     |     | ★   | ★      | ★   |     |     | ★   | ★   | ★   |     |
| 25.4    | ★                    | ★   | ★   | ★   |        | ★   |     | ★   | ★      | ★   |     | ★   | ★      | ★   | ★   |     | ★   | ★   | ★   | ★   |

★Indicates standard available lengths

## Product performance

| Basic Part Number | Lead mm | Typical Drag Torque* Nm | Life @ ¼ Design Load m | Torque To Move Load Nm/kg | Design Load kg | Screw Inertia kgm <sup>2</sup> /m |
|-------------------|---------|-------------------------|------------------------|---------------------------|----------------|-----------------------------------|
| RGLS6-0100        | 2.54    | 0.02                    | 2,540,000              | 0.016                     | 7              | 6.5 x 10 <sup>-6</sup>            |
| RGLS6-0200        | 5.08    | 0.03                    |                        | 0.023                     |                |                                   |
| RGLS6-0500        | 12.70   | 0.04                    |                        | 0.039                     |                |                                   |
| RGLS6-1000        | 25.40   | 0.04                    |                        | 0.070                     |                |                                   |
| RGLS10-0100       | 2.54    | 0.03                    | 2,540,000              | 0.016                     | 16             | 4.2 x 10 <sup>-6</sup>            |
| RGLS10-0200       | 5.08    | 0.04                    |                        | 0.023                     |                |                                   |
| RGLS10-0500       | 12.70   | 0.04                    |                        | 0.039                     |                |                                   |
| RGLS10-1000       | 25.40   | 0.05                    |                        | 0.070                     |                |                                   |
| RGLS13-0100       | 2.54    | 0.04                    | 2,540,000              | 0.018                     | 22             | 20 x 10 <sup>-6</sup>             |
| RGLS13-0200       | 5.08    | 0.04                    |                        | 0.027                     |                |                                   |
| RGLS13-0500       | 12.70   | 0.05                    |                        | 0.047                     |                |                                   |
| RGLS13-1000       | 25.40   | 0.06                    |                        | 0.096                     |                |                                   |
| RGLS16-0100       | 2.54    | 0.04                    | 2,540,000              | 0.020                     | 46             | 3.9 x 10 <sup>-5</sup>            |
| RGLS16-0200       | 5.08    | 0.05                    |                        | 0.031                     |                |                                   |
| RGLS16-0500       | 12.70   | 0.05                    |                        | 0.047                     |                |                                   |
| RGLS16-1000       | 25.40   | 0.06                    |                        | 0.101                     |                |                                   |

\* Assemblies with lengths over 915 mm and/or leads higher than 12.7 mm are likely to have higher drag torques than listed values.

## Part number structure

# RGLS6-0100-1-305

Linear Slide and Series Designator

- RGLS6 series = 6 mm screw
- RGLS10 series = 10 mm screw
- RGLS13 series = 13 mm screw
- RGLS16 series = 16 mm screw

Lead

No. of Carriages

- 1 = 1 driven (standard)
- 2 = 1 driven & 1 passive
- 3 = 1 driven & 2 passive

Guide Length

(Dimension "L")

### **i** Product options

- Special carriage, rail, screw or mounting configuration
- Higher accuracy leadscrew, Left Hand (LH) or Left/Right (L/R) threads
- Alternative guide lengths up to 1000 mm available

### **?** Technical support

- Product overview - see page 7-36



All dimensions in mm

Materials:  
 Guide - Aluminium alloy TFE coated  
 Leadscrew - Stainless steel TFE coated  
 Nut - Aluminium and polyacetal composite

**Associated Products**  
 Reli-a-Flex® couplings: page 8-6  
 Intelligent motors: page 2-2  
 Hardware: page 13-1

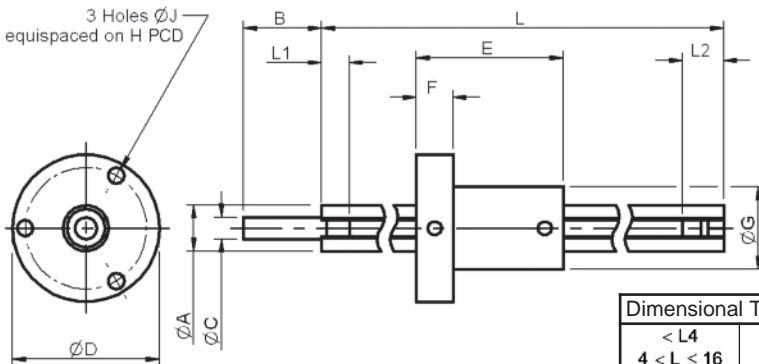

| Dimensional Tolerances |        |
|------------------------|--------|
| < L4                   | ± 0.1  |
| 4 < L ≤ 16             | ± 0.15 |
| 16 < L ≤ 63            | ± 0.2  |
| 63 < L ≤ 250           | ± 0.3  |

**Technical specification**

Total Travel = L - (L1 + L2 + E)

| Series        | ØA          | B     | ØC        | ØD   | E    | F    | ØG   | ØH   | ØJ   | L1   | L2   |
|---------------|-------------|-------|-----------|------|------|------|------|------|------|------|------|
| <b>RSRA5</b>  | 9.24/9.33   | 9.56  | 3.16/3.18 | 24.9 | 25.4 | 7.2  | 14.3 | 19.1 | 2.39 | 9.4  | 9.66 |
| <b>RSRA6</b>  | 12.42/12.5  | 15.75 | 4.75/4.76 | 31.8 | 36.0 | 9.5  | 19.1 | 26.2 | 3.56 | 6.6  | 9.1  |
| <b>RSRA10</b> | 18.77/18.85 | 19.05 | 6.33/6.34 | 44.5 | 51.0 | 12.7 | 28.4 | 37.6 | 4.39 | 9.7  | 17.8 |
| <b>RSRA13</b> | 25.12/25.2  | 19.05 | 6.33/6.34 | 56.6 | 64.0 | 15.9 | 38.0 | 48.8 | 5.08 | 12.2 | 19.6 |

**Standard product sizes - RSRA5 and RSRA6 ScrewRail®**

| Lead mm | Series         |     |     |     |     |     |     |       |     |     |     |     |     |     |
|---------|----------------|-----|-----|-----|-----|-----|-----|-------|-----|-----|-----|-----|-----|-----|
|         | RSRA5          |     |     |     |     |     |     | RSRA6 |     |     |     |     |     |     |
|         | Length L ±1 mm |     |     |     |     |     |     |       |     |     |     |     |     |     |
|         | 102            | 152 | 203 | 254 | 305 | 381 | 457 | 102   | 152 | 203 | 254 | 305 | 381 | 457 |
| 1.27    | ★              | ★   | ★   | ★   |     |     |     | ★     | ★   | ★   | ★   |     |     |     |
| 2.54    |                |     |     |     |     |     |     |       |     |     |     |     |     |     |
| 5.08    |                |     |     |     |     |     |     |       |     |     |     |     |     |     |
| 6.35    |                |     |     | ★   | ★   | ★   | ★   |       |     | ★   | ★   | ★   | ★   |     |
| 12.70   |                |     |     | ★   | ★   | ★   | ★   |       |     |     | ★   | ★   | ★   | ★   |
| 25.40   |                |     |     | ★   | ★   | ★   | ★   |       |     |     | ★   | ★   | ★   | ★   |

★Indicates standard lengths



## Standard product sizes - RSRA10 and RSRA13 ScrewRail®

| Lead mm | Series         |     |     |     |     |     |     |        |     |     |     |     |     |     |
|---------|----------------|-----|-----|-----|-----|-----|-----|--------|-----|-----|-----|-----|-----|-----|
|         | RSRA10         |     |     |     |     |     |     | RSRA13 |     |     |     |     |     |     |
|         | Length L ±1 mm |     |     |     |     |     |     |        |     |     |     |     |     |     |
|         | 152            | 203 | 254 | 305 | 381 | 457 | 610 | 914    | 254 | 305 | 381 | 457 | 610 | 914 |
| 1.27    |                |     |     |     |     |     |     |        |     |     |     |     |     |     |
| 2.54    | ★              | ★   | ★   | ★   | ★   |     |     |        |     | ★   |     |     |     |     |
| 5.08    |                | ★   | ★   | ★   | ★   |     |     |        |     | ★   |     |     |     |     |
| 6.35    |                |     |     |     |     |     |     |        |     |     |     |     |     |     |
| 12.70   |                | ★   | ★   | ★   | ★   |     | ★   |        |     | ★   |     | ★   | ★   |     |
| 25.40   |                |     |     | ★   | ★   | ★   | ★   | ★      |     | ★   |     | ★   | ★   | ★   |

★Indicates standard available lengths

## Product performance

| Basic Part Number | Nominal Rail Dia. mm | Nominal Screw Dia. mm | Lead mm | Max. Drag Torque Nm | Life @ ¼ Design Load m | Torque to Move Load Nm/kg | Design Load kg | Screw Inertia kgm <sup>2</sup> /m | Equiv. Dia. * |
|-------------------|----------------------|-----------------------|---------|---------------------|------------------------|---------------------------|----------------|-----------------------------------|---------------|
| RSRA5-0050        | 9.53                 | 4.76                  | 1.27    | 0.014               | 2,500,000              | 0.007                     | 5              | 0.4 x 10 <sup>-6</sup>            | 7.6           |
| RSRA5-0100        |                      |                       | 2.54    | 0.018               |                        | 0.016                     |                |                                   |               |
| RSRA5-0250        |                      |                       | 6.35    | 0.020               |                        | 0.019                     |                |                                   |               |
| RSRA5-0370        |                      |                       | 9.53    | 0.025               |                        | 0.030                     |                |                                   |               |
| RSRA6-0050        | 12.70                | 6.35                  | 1.27    | 0.015               | 3,800,000              | 0.007                     | 10             | 1.3 x 10 <sup>-6</sup>            | 9.9           |
| RSRA6-0250        |                      |                       | 6.35    | 0.020               |                        | 0.023                     |                |                                   |               |
| RSRA6-0500        |                      |                       | 12.70   | 0.030               |                        | 0.039                     |                |                                   |               |
| RSRA6-1000        |                      |                       | 25.40   | 0.040               |                        | 0.070                     |                |                                   |               |
| RSRA10-0100       | 19.05                | 9.53                  | 2.54    | 0.020               | 4,500,000              | 0.016                     | 20             | 6.5 x 10 <sup>-6</sup>            | 15.2          |
| RSRA10-0200       |                      |                       | 5.08    | 0.030               |                        | 0.023                     |                |                                   |               |
| RSRA10-0500       |                      |                       | 12.70   | 0.040               |                        | 0.039                     |                |                                   |               |
| RSRA10-1000       |                      |                       | 25.40   | 0.045               |                        | 0.070                     |                |                                   |               |
| RSRA13-0100       | 25.40                | 12.70                 | 2.54    | 0.030               | 7,100,000              | 0.016                     | 45             | 20 x 10 <sup>-6</sup>             | 20.5          |
| RSRA13-0200       |                      |                       | 5.08    | 0.040               |                        | 0.023                     |                |                                   |               |
| RSRA13-0500       |                      |                       | 12.70   | 0.045               |                        | 0.039                     |                |                                   |               |
| RSRA13-1000       |                      |                       | 25.40   | 0.060               |                        | 0.070                     |                |                                   |               |

\* ScrewRail® stiffness may be modelled using Classical Beam Deflection Theory with equivalent solid stainless steel beam of diameter given.

## Part number structure

# RSRA6-1000-305MM

ScrewRail® and Series Designator

Lead

Screw Length

### Product options

- End support modifications
- Higher accuracy leadscrew, Left Hand (LH) or Left/Right (L/R) threads
- Alternative ScrewRail® lengths up to 1200 mm available
- Other leads available as custom orders

### Technical support

- Product overview - see [page 7-37](#)



All dimensions in mm

Materials:

- Guide - Aluminium alloy TFE coated
- Leadscrew - Stainless steel TFE coated
- Nut - Aluminium and polyacetal composite

**Associated Products**

- Reli-a-Flex® couplings: page 8-6
- Intelligent motors: page 2-2
- Hardware: page 13-1

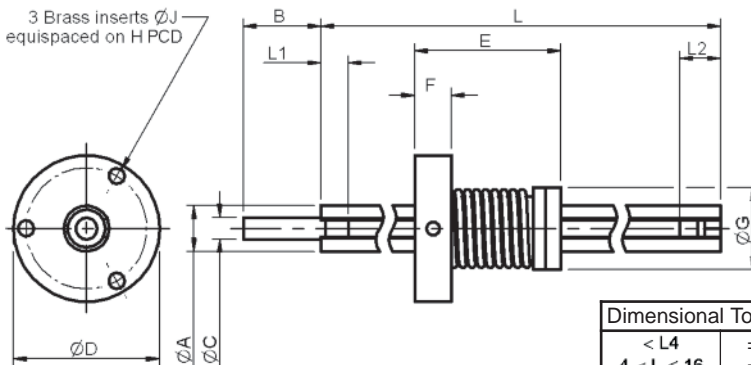

| Dimensional Tolerances |            |
|------------------------|------------|
| $L < 4$                | $\pm 0.1$  |
| $4 < L \leq 16$        | $\pm 0.15$ |
| $16 < L \leq 63$       | $\pm 0.2$  |
| $63 < L \leq 250$      | $\pm 0.3$  |

## Technical specification

Total Travel =  $L - (L1 + L2 + E)$

| Series        | ØA          | B     | ØC        | ØD   | E     | F    | ØG   | ØH    | ØJ<br>Brass<br>Inserts | L1   | L2   |
|---------------|-------------|-------|-----------|------|-------|------|------|-------|------------------------|------|------|
| <b>RSRZ5</b>  | 9.24/9.32   | 9.56  | 3.16/3.18 | 24.9 | 27.94 | 7.2  | 18.5 | 19.05 | 2-56<br>UNC            | 9.4  | 9.66 |
| <b>RSRZ6</b>  | 12.42/12.5  | 15.75 | 4.75/4.76 | 33.3 | 36    | 9.5  | 24.7 | 26.2  | 6-32<br>UNC            | 6.6  | 9.1  |
| <b>RSRZ10</b> | 18.77/18.85 | 19.05 | 6.33/6.34 | 46.0 | 51    | 12.7 | 35.1 | 37.6  | 10-32<br>UNF           | 9.7  | 17.8 |
| <b>RSRZ13</b> | 25.12/25.2  | 19.05 | 6.33/6.34 | 58.4 | 64    | 15.9 | 43.7 | 48.8  | 10-32<br>UNF           | 12.2 | 19.6 |

## Standard product sizes - RSRZ5 and RSRZ6 ScrewRail®

| Lead mm | Series         |     |     |     |     |     |     |       |     |     |     |     |     |     |
|---------|----------------|-----|-----|-----|-----|-----|-----|-------|-----|-----|-----|-----|-----|-----|
|         | RSRZ5          |     |     |     |     |     |     | RSRZ6 |     |     |     |     |     |     |
|         | Length L ±1 mm |     |     |     |     |     |     |       |     |     |     |     |     |     |
|         | 102            | 152 | 203 | 254 | 305 | 381 | 457 | 102   | 152 | 203 | 254 | 305 | 381 | 457 |
| 1.27    | ★              | ★   | ★   | ★   |     |     |     | ★     | ★   | ★   | ★   |     |     |     |
| 2.54    |                |     |     |     |     |     |     |       |     |     |     |     |     |     |
| 5.08    |                |     |     |     |     |     |     |       |     |     |     |     |     |     |
| 6.35    |                |     | ★   | ★   | ★   | ★   |     |       |     | ★   | ★   | ★   | ★   |     |
| 12.70   |                |     |     | ★   | ★   | ★   | ★   |       |     |     | ★   | ★   | ★   | ★   |
| 25.40   |                |     |     | ★   | ★   | ★   | ★   |       |     |     | ★   | ★   | ★   | ★   |

★Indicates standard lengths

Leadscrew & Nut Assemblies



## Standard product sizes - RSRZ10 and RSRZ13 ScrewRail®

| Lead mm | Series         |     |     |     |     |     |     |     |     |        |     |     |     |     |     |
|---------|----------------|-----|-----|-----|-----|-----|-----|-----|-----|--------|-----|-----|-----|-----|-----|
|         | RSRZ10         |     |     |     |     |     |     |     |     | RSRZ13 |     |     |     |     |     |
|         | Length L ±1 mm |     |     |     |     |     |     |     |     |        |     |     |     |     |     |
|         | 152            | 203 | 254 | 305 | 381 | 457 | 533 | 610 | 914 | 254    | 305 | 381 | 457 | 610 | 914 |
| 1.27    |                |     |     |     |     |     |     |     |     |        |     |     |     |     |     |
| 2.54    | ★              | ★   | ★   | ★   | ★   |     |     |     |     |        | ★   |     |     |     |     |
| 5.08    |                | ★   | ★   | ★   | ★   |     |     |     |     |        | ★   |     |     |     |     |
| 6.35    |                |     |     |     |     |     |     |     |     |        |     |     |     |     |     |
| 12.70   |                | ★   | ★   | ★   | ★   |     | ★   | ★   |     |        | ★   |     | ★   | ★   |     |
| 25.40   |                |     |     | ★   | ★   | ★   | ★   | ★   | ★   |        | ★   |     | ★   | ★   | ★   |

★Indicates standard lengths

## Product performance

| Basic Part Number | Nominal Rail Dia. mm | Nominal Screw Dia. mm | Lead mm | Max. Drag Torque Nm | Life @ ¼ Design Load m | Torque to Move Load Nm/kg | Design Load kg | Screw Inertia kgm²/m   | Equiv. Dia. * |
|-------------------|----------------------|-----------------------|---------|---------------------|------------------------|---------------------------|----------------|------------------------|---------------|
| RSRZ5-0050        | 9.53                 | 4.76                  | 1.27    | 0.014               | 1,300,000              | 0.007                     | 5              | 0.4 x 10 <sup>-6</sup> | 7.6           |
| RSRZ5-0100        |                      |                       | 2.54    | 0.018               |                        | 0.016                     |                |                        |               |
| RSRZ5-0250        |                      |                       | 6.35    | 0.020               |                        | 0.019                     |                |                        |               |
| RSRZ5-0370        |                      |                       | 9.53    | 0.025               |                        | 0.030                     |                |                        |               |
| RSRZ6-0050        | 12.70                | 6.35                  | 1.27    | 0.020               | 1,900,000              | 0.007                     | 10             | 1.3 x 10 <sup>-6</sup> | 9.9           |
| RSRZ6-0250        |                      |                       | 6.35    | 0.030               |                        | 0.023                     |                |                        |               |
| RSRZ6-0500        |                      |                       | 12.70   | 0.040               |                        | 0.039                     |                |                        |               |
| RSRZ6-1000        |                      |                       | 25.40   | 0.045               |                        | 0.070                     |                |                        |               |
| RSRZ10-0100       | 19.05                | 9.53                  | 2.54    | 0.045               | 2,300,000              | 0.016                     | 20             | 6.5 x 10 <sup>-6</sup> | 15.2          |
| RSRZ10-0200       |                      |                       | 5.08    | 0.047               |                        | 0.023                     |                |                        |               |
| RSRZ10-0500       |                      |                       | 12.70   | 0.050               |                        | 0.039                     |                |                        |               |
| RSRZ10-1000       |                      |                       | 25.40   | 0.053               |                        | 0.070                     |                |                        |               |
| RSRZ13-0100       | 25.40                | 12.70                 | 2.54    | 0.057               | 3,500,000              | 0.016                     | 45             | 20 x 10 <sup>-6</sup>  | 20.5          |
| RSRZ13-0200       |                      |                       | 5.08    | 0.060               |                        | 0.023                     |                |                        |               |
| RSRZ13-0500       |                      |                       | 12.70   | 0.064               |                        | 0.039                     |                |                        |               |
| RSRZ13-1000       |                      |                       | 25.40   | 0.067               |                        | 0.070                     |                |                        |               |

\* ScrewRail® stiffness may be modelled using Classical Beam Deflection Theory with equivalent solid stainless steel beam of diameter given.

## Part number structure

# RSRZ6-1000-305MM

ScrewRail® and Series Designator

Lead

Screw Length

### **i** Product options

- End support modifications
- Higher accuracy leadscrew, Left Hand (LH) or Left/Right (L/R) threads
- Alternative ScrewRail® lengths up to 1200 mm available
- Other leads available as custom orders

### **?** Technical support

- Product overview - see page 7-37





## Section Contents

|  |           |
|--|-----------|
| Couplings and Collars - Overview .....                 | Page 8-2  |
| Reli-a-Flex® Micro Couplings.....                      | Page 8-8  |
| Reli-a-Flex® Precision Couplings, Set Screw Type ..... | Page 8-10 |
| Reli-a-Flex® Precision Couplings, Clamp Type .....     | Page 8-12 |
| Reli-a-Flex® Couplings, Reli-a-Grip™ Clamp Type .....  | Page 8-14 |
| Custom Reli-a-Flex® Couplings .....                    | Page 8-16 |
| Stocked Reli-a-Flex® Couplings.....                    | Page 8-17 |
| Bellows Couplings .....                                | Page 8-18 |
| Flexible Disc Spring Couplings.....                    | Page 8-24 |
| Oldham Couplings .....                                 | Page 8-30 |
| Membrane Couplings .....                               | Page 8-32 |
| Curved Jaw Couplings.....                              | Page 8-36 |
| Micro Spiral Beam Couplings .....                      | Page 8-38 |
| Spiral Beam Couplings .....                            | Page 8-39 |
| Spiral Beam Stainless Steel Couplings .....            | Page 8-44 |
| Radial Tooth Couplings .....                           | Page 8-46 |
| Friction Clutches .....                                | Page 8-47 |
| Solid Couplings .....                                  | Page 8-51 |
| Double Width Shaft Clamp Collars .....                 | Page 8-52 |
| Shaft Clamp Collars .....                              | Page 8-53 |
| One Piece Threaded Collars .....                       | Page 8-54 |
| One Piece Set Screw Collars.....                       | Page 8-55 |
| Technical Information.....                             | Page T8-1 |



## Introduction to the range

In many cases machine designers give limited thought to the shaft coupling. They devote their time to the more expensive components, overlooking the fact that the performance of a machine is only as good as the connections of its shafts. Reliance is fully aware of the importance of the shaft coupling and that they are often a critical part of the drive system. The Reliance range of shaft couplings has been carefully designed and tested to provide trouble free operation over many millions of cycles.



Perfect alignment is not practical in applications where two shafts need to be joined and therefore some level of misalignment will always occur. This misalignment is usually the result of the support block manufacturing tolerances and structural alignment. Unless these tolerances are very precise use of a solid coupling will result in high shaft loading and significant bearing loads. In certain cases this misalignment is limited to angular or radial misalignments, but is more often a combination of the two. Therefore, careful shaft coupling selection is important as differing configurations of coupling are designed to perform very differently dependent upon the application, and, as a consequence, have very different benefits and drawbacks.

Reliance engineers have many years of experience working with and specifying shaft couplings and are very happy to offer applications advice on coupling selection.

### Reli-a-Flex®

The Reli-a-Flex® range of couplings is an aluminium alloy, one piece configuration, which has been designed in-house at Reliance to provide very smooth transmission of motion, high torsional stiffness, low bearing loads, and long life. The patented slot pattern was developed after many months of analysis and test to provide the best balance between zero backlash, torsional stiffness and low bearing load, whilst attaining an operational life in excess of 50,000,000 cycles at rated load and 80% offset. With two sets of identical slots, the Reli-a-Flex® coupling is constant velocity by design and handles angular, parallel and axial offset. Available in sizes from 6 to 40 mm outside diameter and allowable speeds up to 70,000 rpm, the Reli-a-Flex® coupling provides a very reliable one piece coupling design that approaches the performance of a bellows coupling.

Also for customers that require a modified or completely bespoke Reli-a-Flex® coupling, Reliance has developed a unique computer-based design and performance prediction tool. This tool allows our engineers to experiment quickly with different coupling configurations and to design a coupling to meet either space envelope restrictions or performance requirements.

### Oldham

Oldham couplings are ideal where high degrees of parallel misalignment are present, assembly access is restricted and electrical insulation is required. Their construction of aluminium alloy hubs and nylon or acetal centre blocks allows separate assembly of hubs onto shafts and then simple engagement with the centre block on assembly where shaft movement is restricted. In addition, the construction of the centre block allows it to act as a torque limiter or overload device.



### Bellows

Maintenance free zero-backlash bellows couplings are available with three construction options: for highest accuracy, nickel bellows; for torque transmission, stainless steel bellows; and where space is restricted, bronze bellows are available down to 12 mm outer diameter. Shaft fixing options are both set screw and clamp for the stainless steel and nickel bellows options, with the brass bellows option available in clamp type only.

### Flexible disc

A number of different options of flexible disc couplings are available, based on both single and double disc spring construction. Please note that single disc spring couplings should only be used where the misalignment between the shafts is restricted to angular and axial. Single disc spring couplings cannot be used where radial misalignments are present. The RFSXK-2213 and 3019 type uses a novel design which places the clamps inboard of the disc springs to give the shortest possible overall length. The RFSXK-3850 type has an extended centre piece which allows high radial misalignment capability whilst maintaining good accuracy of transmission.

### Curved jaw

Curved jaw couplings are available with both set screw and clamp hub type fixing methods. They are an ideal solution for reducing system torque ripple with a choice of three damping elements for high, medium and low torques.

### Spiral beam

Available in stainless steel or aluminium and with a clamp or set screw style fixing, spiral beam couplings are suitable for general applications. Manufactured in one piece, spiral beam couplings are also maintenance-free.

### Friction clutches

Friction clutches are available with two spring types. For lower torques up to 30 Ncm, the wire compression spring type should be used. For higher torques up to 120 Ncm, the disc spring version is the ideal choice.

### Radial tooth

Radial tooth couplings are self centering on assembly and can be used to transmit high torques. These couplings must not be used where radial and axial misalignments are present and may require light lubrication depending on the application conditions.

### Solid

Stainless steel or aluminium solid couplings, in one or two piece construction, can be used for connecting two accurately aligned shafts. Screws are prevented from loosening during operation by precision honed bores and Nypatch anti-vibration hardware, providing superior holding strength.



Bespoke coupling designed for a medical dosing machine



**Reli-a-Flex®** - Unique design, maximises torsional stiffness without introducing high bearing loads. Chambered for ease of assembly.



**Bellows** - High accuracy, light duty. Maintenance free.



**Flexible disc spring** - Ideal for low torque applications requiring accuracy. Both external and internal hubs available.



**Oldham** - Large offset, designed to separate for assembly. Electrically insulating disc.



**Membrane** - Light duty, with an insulating fibreglass reinforced centre. Compact overall length. Zero backlash.



**Curved jaw** - Shock absorbing, low cost general purpose coupling, ideal for reducing torque ripple.



**Spiral beam** - Universal one piece coupling. Aluminium and stainless steel versions available.



**Radial tooth** - Positive connection, minimal axial misalignment.



**Friction clutches** - Variable torque settings. Gear manufactured to requirement.



**Solid** - One and two piece options. Excellent for accurately aligned shafts with high torque loads.



**Clamp collars** - No shaft marking, integral location face. One or two piece construction.



**Custom Design** - Designed and manufactured to suit your application, please contact us.



The couplings featured in this catalogue have been carefully selected to accommodate varying degrees of shaft misalignment whilst offering minimum distortion of rotation.

No one coupling provides a universal solution but the selection table below summarises the salient performance features for ease of comparison.

Full details for each coupling can be found on the product pages, with further technical information on pages T8-1 to T8-4. If you require technical support please contact us to discuss your application and we will be happy to help you select an appropriate coupling.

Comparative star rating:  
 ●●●● most suitable  
 ● least suitable  
 ☒ not applicable  
 ■ please enquire

| Coupling Feature \ Coupling Style | Electrically insulating | Vibration damping | High reliability | No inherent backlash | Torque capacity | Misalignment capability | Low bearing load | Accuracy | Price / performance |
|-----------------------------------|-------------------------|-------------------|------------------|----------------------|-----------------|-------------------------|------------------|----------|---------------------|
| Reli-a-Flex®                      | ■                       | ●●                | ●●●●             | ●●●●                 | ●●●●            | ●●●                     | ●●●●             | ●●●      | ●●●●                |
| Bellows                           | ☒                       | ●                 | ●●●●             | ●●●●                 | ●●●             | ●●●                     | ●●●●             | ●●●●     | ●●                  |
| Flexible disc spring*             | ☒                       | ●                 | ●●●              | ●●●●                 | ●●              | ●●                      | ●●●*             | ●●●      | ●●                  |
| Oldham                            | ●●●●                    | ●●                | ●●●              | ☒                    | ●●●             | ●●●●                    | ●                | ●        | ●●●                 |
| Membrane                          | ●●●●                    | ●●●               | ●●               | ●●●●                 | ●●              | ●●●                     | ●●               | ●●       | ●●●                 |
| Curved jaw                        | ●●●●                    | ●●●               | ●●               | ☒                    | ●●●●            | ●●                      | ●                | ●        | ●●●                 |
| Spiral beam                       | ☒                       | ●●                | ●●               | ●●●                  | ●●●             | ●●●                     | ●●●              | ●●       | ●●●●                |
| Radial tooth                      | ☒                       | ☒                 | ●●●              | ●●                   | ●●●●            | ☒                       | ●                | ●        | ●●                  |
| Friction clutches                 | ☒                       | ●                 | ☒                | ☒                    | ■               | ☒                       | ■                | ☒        | ●●                  |
| Solid                             | ☒                       | ☒                 | ●●●●             | ●●●●                 | ●●●●            | ☒                       | ●                | ●●●●     | ●●●●                |

\*single disc suitable for angular offset only



## Reli-a-Flex®, specifically designed and manufactured by Reliance to:

### ∞ Improve system accuracy







The Reli-a-Flex® coupling provides excellent kinematic transfer of motion with high torsional stiffness, zero backlash and constant velocity.

### ∞ Extend system life

The Reli-a-Flex® coupling introduces negligible radial and axial bearing loads, extending system life.



## The range of Reli-a-Flex® flexible shaft couplings

|   |                               |  |
|---|-------------------------------|--|
|    | <b>Short or Long</b>          | <ul style="list-style-type: none"> <li>RCS type (short) where space is limited</li> <li>RCL type (long) where greater parallel offset and greater accuracy are required</li> </ul>   |
|    | <b>Reli-a-Grip™</b>           | <ul style="list-style-type: none"> <li>The Reli-a-Grip™ clamp enables Reli-a-Flex® coupling to be used to its full potential. Greater torques can be transmitted without the need to use set screws, which can potentially damage the shaft</li> </ul> |
|   | <b>Precision or Micro</b>     | <ul style="list-style-type: none"> <li>Precision coupling with outer diameters from 13 to 25 mm</li> <li>Micro coupling with outer diameters from 6 to 10 mm</li> </ul>  |
|  | <b>Clamp or Set screw</b>     | <ul style="list-style-type: none"> <li>Clamp type leaves shafts unmarked</li> <li>Set screw type where higher speeds are required</li> </ul>   |
|  | <b>Electrically insulated</b> | <ul style="list-style-type: none"> <li>Protects delicate instruments from powered drive</li> <li>Available with selected bores on RCL type aluminium couplings, sizes 20 and 25</li> </ul>   |
|  | <b>Custom designs</b>         | <ul style="list-style-type: none"> <li>Predictable performances</li> <li>Available with outer diameters from 6 to 40 mm</li> <li>Alternative materials may be specified</li> </ul>   |

Please enquire

Please enquire

## Patented Reli-a-Flex®

|                 |               |
|-----------------|---------------|
| UK Number       | 2316735       |
| US Number       | 6,203,437 B1  |
| European Number | EP 0922168 B1 |
| Japanese Number | 4,083,227     |



### Picture perfect scanning with Reli-a-Flex® coupling

With the latest advances in digital optical scanning speed, professional flatbed scanner manufacturers are demanding more accuracy from their drive systems. A European company with leading edge technology in drum and flatbed scanners, image setting and integrated media processor products uses Reli-a-Flex® couplings in all their flatbed products. With XY technology, speeds of up to 50 scans per hour and resolutions of up to 5400 dpi, the accuracy and reliability of the Reli-a-Flex® coupling makes it the ideal choice.

Prior to the introduction of the Reli-a-Flex® coupling slight variations in the speed of the CCD element caused errors when trying to capture high resolution images. These errors manifest themselves as a colour registration defect, which resulted in an unacceptable banding effect across the image. Although these errors were small (typically 3.0 microns) they could easily be detected by the naked eye.

The cause of these errors was identified as the flatbed drive system. Introduction of a Reli-a-Flex® coupling manufactured from low inertia Grade 7075-T6 Aluminium was instrumental in bringing these registration defects under control. The unique slit pattern with radial rather than spiral slits gives the Reli-a-Flex® coupling high torsional stiffness and unsurpassed accuracy. However, with Reli-a-Flex® couplings high torsional stiffness does not mean high bearing loads, the Reli-a-Flex® coupling slit pattern has been carefully designed to give low bearing loads in conjunction with its high torsional stiffness.

Having been tested to 50 million cycles at rated torque, the Reli-a-Flex® coupling is also ideal for high duty cycle applications such as busy printing and typesetting applications. All in all the Reli-a-Flex® coupling has proved itself to be ideal for accurate positioning and responsive servo systems.





1.5 - 5 mm  
Bore

# Micro Reli-a-Flex® Couplings

All dimensions in mm  
General tolerances  $\pm 0.13$  mm  
Material: Aluminium alloy grade 7075-T6  
Finish: Alocrom 1000

**Associated Products**  
Shafts: page 11-2  
Bearings: page 12-1  
Leadscrews: page 7-1  
Intelligent motors: page 2-2

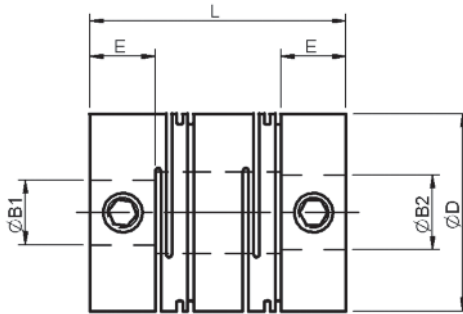

RCL (long type) RCS (short type)

Couplings  
and Collars

## Part number selection table

| Example Part No:- <b>RCS A 8 - 4-2</b> |          |      |  | Dimensions (mm) |   |   |     |        |            |              |
|--|----------|------|--|-----------------|---|---|-----|--------|------------|--------------|
| Basic Part No                          | Material | Size | Standard Bore Sizes<br>ØB1 and ØB2<br>(bore tolerance +0.010/-0.000) |                 |   |   | O/D | Length | Hub Length | Fitted Screw |
|  |          |      | 1.5  | 2               | 3 | 4 | 5   | ØD     | L          | E            |
| RCS<br>(short)                         | A        | 6    | 1.5  | 2               | 3 |   | 6.0 | 9.35   | 2.80       | M1.2*        |
|  |          | 8    |  | 2               | 3 | 4 | 8.0 | 11.70  | 3.20       | M1.6         |
|  |          | 10   |  |                 | 3 | 4 | 5   | 10.0   | 13.65      | 4.00         |
| RCL<br>(long)                          | A        | 6    | 1.5  | 2               | 3 |   | 6.0 | 12.50  | 2.80       | M1.2*        |
|  |          | 8    |  | 2               | 3 | 4 | 8.0 | 14.50  | 3.20       | M1.6         |
|  |          | 10   |  |                 | 3 | 4 | 5   | 10.0   | 17.00      | 4.00         |

Maximum shaft intrusion when fitted = E+2 mm.

\* Coupling fitted with stainless steel slotted head set screws.

Note: bores may be left unalocromed.

### Product options

- Alternative bore sizes
- Imperial bores
- Alternative materials
- Custom designs - see page 8-16
- Product overview - see pages 8-2 to 8-7
- Selected items in stock, at reduced prices - see page 8-17







### Technical specification

| Basic Part No | Material | Size | Torsional <sup>1</sup> Stiffness Nm/rad | Radial Compliance microns/N | Misalignment |             |          | Max Inertia gcm <sup>2</sup> | Max Mass g |
|---------------|----------|------|---|-----------------------------|--------------|-------------|----------|------------------------------|------------|
|               |          |      |   |                             | Parallel mm  | Angular deg | Axial mm |                              |            |
| RCS (short)   | A        | 6    | 4.19                                    | 21.0                        | ±0.02        | ±1.7        | ±0.06    | 0.03                         | 0.65       |
|               |          | 8    | 8.70                                    | 35.0                        | ±0.05        | ±2.0        | ±0.10    | 0.11                         | 1.27       |
|               |          | 10   | 16.80                                   | 28.0                        | ±0.06        | ±2.0        | ±0.17    | 0.33                         | 2.34       |
| RCL (long)    | A        | 6    | 4.30                                    | 79.0                        | ±0.04        | ±1.7        | ±0.06    | 0.05                         | 0.95       |
|               |          | 8    | 8.70                                    | 102.0                       | ±0.10        | ±2.0        | ±0.10    | 0.15                         | 1.66       |
|               |          | 10   | 16.81                                   | 83.0                        | ±0.12        | ±2.0        | ±0.17    | 0.43                         | 3.05       |

Specifications vary according to bore size. For exact figures, please enquire.

<sup>1</sup> Typical torsional stiffness.

Couplings and Collars

### Torque and speed capacity

| Basic Part No | Material | Size | Typical Torque Capacity |                  |         | Max Speed rpm |
|---------------|----------|------|-------------------------|------------------|---------|---------------|
|               |          |      | Reversing Nm            | Non Reversing Nm | Peak Nm |               |
| RCS (short)   | A        | 6    | 0.10                    | 0.15             | 0.25    | 70,000        |
|               |          | 8    | 0.20                    | 0.30             | 0.50    | 40,000        |
|               |          | 10   | 0.30                    | 0.45             | 0.75    | 35,000        |
| RCL (long)    | A        | 6    | 0.10                    | 0.15             | 0.25    | 32,000        |
|               |          | 8    | 0.20                    | 0.30             | 0.50    | 24,000        |
|               |          | 10   | 0.30                    | 0.45             | 0.75    | 22,000        |

Specifications vary according to bore size. For exact figures, please enquire.

### ? Technical support

- Zero backlash, reliable one-piece construction
- Unique design maximises torsional stiffness without inducing high bearing loads
- Minimal velocity and positional fluctuations
- Over 50,000,000 test cycles at rated load and 80% offset without failure
- Maintenance free
- Recommended temperature range -80°C to +80°C
- Technical information - see [page T8-1](#)
- Installation information - see [page T8-3](#)





# 3 - 20 mm Bore

# Reli-a-Flex® Precision Couplings Set Screw Type

All dimensions in mm  
 General tolerances  $\pm 0.13$  mm  
 Material: Aluminium alloy grade 7075-T6  
 Finish: Alocrom 1000

**Associated Products**  
 Shafts: page 11-2  
 Bearings: page 12-1  
 Leadscrews: page 7-1  
 Intelligent motors: page 2-2

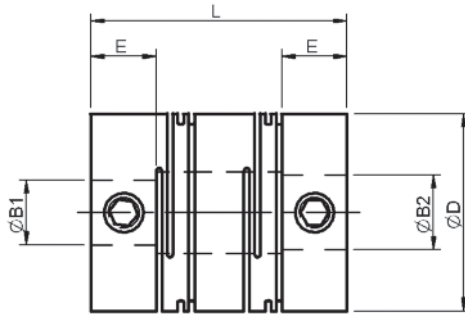

**RCL** (long type) **RCS** (short type)

Couplings are chambered for ease of assembly and fitted with stainless steel screws.

## Part number selection table

| Example Part No:- <b>RCS A 20 - 8-5</b> |          |      |  | Dimensions (mm) |             |                 |              |
|---|----------|------|--|-----------------|-------------|-----------------|--------------|
| Basic Part No                           | Material | Size | Standard Bore Sizes<br>ØB1 and ØB2<br>(bore tolerance +0.020/-0.000) | O/D<br>ØD       | Length<br>L | Hub Length<br>E | Fitted Screw |
| RCS<br>(short)                          | A        | 13   | 3 4 5 6  | 13.0            | 16.80       | 5.00            | M2.5         |
|   |          | 16   | 4 5 6 8  | 16.0            | 19.75       | 5.90            | M3           |
|   |          | 20   | 5 6 8 10   | 20.0            | 21.50       | 6.60            | M4           |
|   |          | 25   | 6 8 10 12  | 25.0            | 25.80       | 7.60            | M5           |
|   |          | 30   | 8 10 12 15   | 30.0            | 30.30       | 9.10            | M6           |
|   |          | 40   | 10 12 15 20  | 40.0            | 35.95       | 10.60           | M8           |
| RCL<br>(long)                           | A        | 13   | 3 4 5 6  | 13.0            | 20.00       | 5.00            | M2.5         |
|   |          | 16   | 4 5 6 8  | 16.0            | 23.50       | 5.90            | M3           |
|   |          | 20   | 5 6 8 10   | 20.0            | 26.00       | 6.60            | M4           |
|   |          | 25   | 6 8 10 12  | 25.0            | 34.00       | 7.60            | M5           |
|   |          | 30   | 8 10 12 15   | 30.0            | 44.00       | 9.10            | M6           |
|   |          | 40   | 10 12 15 20  | 40.0            | 57.00       | 10.60           | M8           |

Maximum shaft intrusion when fitted = E+2 mm. Note: bores may be left unalocromed.

### **i** Product options

- Alternative bore sizes
- Imperial bores
- Alternative materials
- Electrically insulated, sizes 20 and 25
- Reli-a-Grip™ clamp type - see page 8-14
- Custom designs - see page 8-16
- Product overview - see pages 8-2 to 8-7
- Selected items in stock, at reduced prices - see page 8-17



### Technical specification

| Basic Part No | Material | Size | Torsional <sup>1</sup> Stiffness Nm/rad | Radial Compliance microns/N | Misalignment |             |          | Max Inertia gcm <sup>2</sup> | Max Mass g |
|---------------|----------|------|---|-----------------------------|--------------|-------------|----------|------------------------------|------------|
|               |          |      |   |                             | Parallel mm  | Angular deg | Axial mm |                              |            |
| RCS (short)   | A        | 13   | 45.00                                   | 29.2                        | ±0.08        | ±2.5        | ±0.30    | 1.1                          | 4.74       |
|               |          | 16   | 67.00                                   | 28.9                        | ±0.10        | ±2.5        | ±0.40    | 3.0                          | 8.42       |
|               |          | 20   | 107.50                                  | 23.4                        | ±0.12        | ±3.0        | ±0.50    | 8.8                          | 14.62      |
|               |          | 25   | 173.60                                  | 20.0                        | ±0.16        | ±3.0        | ±0.70    | 24.0                         | 27.50      |
|               |          | 30   | 246.10                                  | 15.4                        | ±0.20        | ±3.5        | ±0.85    | 58.0                         | 45.98      |
|               |          | 40   | 465.20                                  | 13.4                        | ±0.25        | ±3.5        | ±1.25    | 220.0                        | 97.30      |
| RCL (long)    | A        | 13   | 53.50                                   | 64.3                        | ±0.15        | ±2.5        | ±0.30    | 1.3                          | 5.83       |
|               |          | 16   | 81.00                                   | 65.1                        | ±0.20        | ±2.5        | ±0.40    | 3.6                          | 10.33      |
|               |          | 20   | 130.00                                  | 62.0                        | ±0.25        | ±3.0        | ±0.50    | 9.9                          | 18.20      |
|               |          | 25   | 216.10                                  | 82.2                        | ±0.40        | ±3.0        | ±0.70    | 33.0                         | 38.40      |
|               |          | 30   | 315.10                                  | 85.0                        | ±0.60        | ±3.5        | ±0.85    | 89.0                         | 71.82      |
|               |          | 40   | 606.20                                  | 89.0                        | ±0.95        | ±3.5        | ±1.25    | 370.0                        | 168.57     |

Specifications vary according to bore size. For exact figures, please enquire. <sup>1</sup> Typical torsional stiffness.

### Torque and speed capacity

| Basic Part No | Material | Size | Typical Torque Capacity |                  |         | Max Speed rpm |
|---------------|----------|------|-------------------------|------------------|---------|---------------|
|               |          |      | Reversing Nm            | Non Reversing Nm | Peak Nm |               |
| RCS (short)   | A        | 13   | 0.50                    | 0.70             | 1.20    | 30,000        |
|               |          | 16   | 0.75                    | 1.15             | 1.90    | 25,000        |
|               |          | 20   | 1.30                    | 1.95             | 3.25    | 20,000        |
|               |          | 25   | 2.05                    | 3.10             | 5.20    | 15,000        |
|               |          | 30   | 2.90                    | 4.40             | 7.35    | 11,000        |
|               |          | 40   | 5.50                    | 8.30             | 13.80   | 6,500         |
| RCL (long)    | A        | 13   | 0.50                    | 0.70             | 1.20    | 20,000        |
|               |          | 16   | 0.75                    | 1.15             | 1.90    | 17,000        |
|               |          | 20   | 1.30                    | 1.95             | 3.25    | 15,000        |
|               |          | 25   | 2.05                    | 3.10             | 5.20    | 12,000        |
|               |          | 30   | 2.90                    | 4.40             | 7.35    | 10,000        |
|               |          | 40   | 5.50                    | 8.30             | 13.80   | 6,500         |

Specifications vary according to bore size. For exact figures, please enquire.

### ? Technical support

- Zero backlash, reliable one-piece construction
- Unique design maximises torsional stiffness without inducing high bearing loads
- Minimal velocity and positional fluctuations
- Over 50,000,000 test cycles at rated load and 80% offset without failure
- Maintenance free
- Recommended temperature range -80°C to +80°C
- Technical information - see [page T8-1](#)
- Installation information - see [page T8-3](#)





# 3 - 20 mm Bore

# Reli-a-Flex® Precision Couplings Clamp Type

All dimensions in mm  
 General tolerances  $\pm 0.13\text{mm}$   
 Material: Aluminium alloy grade 7075-T6  
 Finish: Alocrom 1000

**Associated Products**  
 Shafts: page 11-2  
 Bearings: page 12-1  
 Leadscrews: page 7-1  
 Intelligent motors: page 2-2

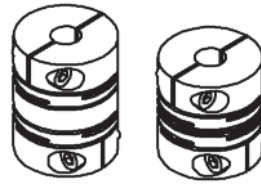
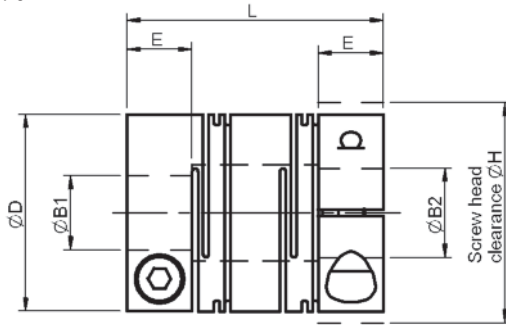

**RCL** (long type) **RCS** (short type)

Couplings are chambered for ease of assembly and fitted with stainless steel screws.

## Part number selection table

| Example Part No:- <b>RCS A 20C - 8-5</b> |          |      |  | Dimensions (mm) |      |             |                 |              |
|--|----------|------|--|-----------------|------|-------------|-----------------|--------------|
| Basic Part No                            | Material | Size | Standard Bore Sizes<br>ØB1 and ØB2<br>(bore tolerance +0.020/-0.000) | O/D             |      | Length<br>L | Hub Length<br>E | Fitted Screw |
|  |          |      |  | ØD              | ØH   |             |                 |              |
| RCS<br>(short)                           | A        | 13C  | 3 4 5 6  | 13.0            | 14.5 | 16.80       | 5.00            | M1.6         |
|  |          | 16C  | 3 4 5 6 8  | 16.0            | 18.0 | 19.75       | 5.90            | M2           |
|  |          | 20C  | 4 5 6 8 10   | 20.0            | 21.8 | 21.50       | 6.60            | M2.5         |
|  |          | 25C  | 5 6 8 10 12  | 25.0            | 26.9 | 25.80       | 7.60            | M3           |
|  |          | 30C  | 6 8 10 12 15   | 30.0            | 32.3 | 30.30       | 9.10            | M4           |
|  |          | 40C  | 8 10 12 15 20  | 40.0            | 41.0 | 35.95       | 10.60           | M5           |
| RCL<br>(long)                            | A        | 13C  | 3 4 5 6  | 13.0            | 14.5 | 20.00       | 5.00            | M1.6         |
|  |          | 16C  | 3 4 5 6 8  | 16.0            | 18.0 | 23.50       | 5.90            | M2           |
|  |          | 20C  | 4 5 6 8 10   | 20.0            | 21.8 | 26.00       | 6.60            | M2.5         |
|  |          | 25C  | 5 6 8 10 12  | 25.0            | 26.9 | 34.00       | 7.60            | M3           |
|  |          | 30C  | 6 8 10 12 15   | 30.0            | 32.3 | 44.00       | 9.10            | M4           |
|  |          | 40C  | 8 10 12 15 20  | 40.0            | 41.0 | 57.00       | 10.60           | M5           |

Maximum shaft intrusion when fitted = E+2 mm. Note: bores may be left unalocromed.

### **i** Product options

- Alternative bore sizes
- Imperial bores
- Alternative materials
- Electrically insulated, sizes 20 and 25
- Set screw fixing
- Reli-a-Grip™ clamp type - see page 8-14
- Custom designs - see page 8-16
- Product overview - see pages 8-2 to 8-7
- Selected items in stock, at reduced prices - see page 8-17





### Technical specification

| Basic Part No | Material | Size | Torsional <sup>1</sup> Stiffness Nm/rad | Radial Compliance microns/N | Misalignment |             |          | Max Inertia g.cm <sup>2</sup> | Max Mass g |
|---------------|----------|------|---|-----------------------------|--------------|-------------|----------|-------------------------------|------------|
|               |          |      |   |                             | Parallel mm  | Angular deg | Axial mm |                               |            |
| RCS (short)   | A        | 13C  | 45.00                                   | 29.2                        | ±0.08        | ±2.5        | ±0.30    | 1.0                           | 4.4        |
|               |          | 16C  | 67.00                                   | 28.9                        | ±0.10        | ±2.5        | ±0.40    | 2.9                           | 8.2        |
|               |          | 20C  | 107.50                                  | 23.4                        | ±0.12        | ±3.0        | ±0.50    | 7.8                           | 14.3       |
|               |          | 25C  | 177.60                                  | 20.0                        | ±0.40        | ±3.0        | ±0.70    | 23.0                          | 27.5       |
|               |          | 30C  | 258.10                                  | 15.4                        | ±0.60        | ±3.5        | ±0.85    | 55.0                          | 46.4       |
|               |          | 40C  | 481.20                                  | 13.4                        | ±0.95        | ±3.5        | ±1.25    | 200.0                         | 97.2       |
| RCL (long)    | A        | 13C  | 53.50                                   | 64.3                        | ±0.15        | ±2.5        | ±0.30    | 1.2                           | 5.5        |
|               |          | 16C  | 81.00                                   | 65.1                        | ±0.20        | ±2.5        | ±0.40    | 3.2                           | 10.1       |
|               |          | 20C  | 133.00                                  | 62.0                        | ±0.25        | ±3.0        | ±0.50    | 9.0                           | 18.7       |
|               |          | 25C  | 223.10                                  | 82.2                        | ±0.40        | ±3.0        | ±0.70    | 31.0                          | 38.5       |
|               |          | 30C  | 330.60                                  | 85.0                        | ±0.60        | ±3.5        | ±0.85    | 86.0                          | 72.6       |
|               |          | 40C  | 627.30                                  | 89.0                        | ±0.95        | ±3.5        | ±1.25    | 350.0                         | 168.7      |

Specifications vary according to bore size. For exact figures, please enquire.

<sup>1</sup> Typical torsional stiffness.

Couplings and Collars

### Torque and speed capacity

| Basic Part No             | Material | Size | Typical Torque Capacity |                  |         | Max Speed rpm |
|---------------------------|----------|------|-------------------------|------------------|---------|---------------|
|                           |          |      | Reversing Nm            | Non Reversing Nm | Peak Nm |               |
| RCS (short) or RCL (long) | A        | 13C  | 0.35                    | 0.55             | 0.80    | 12,000        |
|                           |          | 16C  | 0.55                    | 0.85             | 1.25    | 10,000        |
|                           |          | 20C  | 0.95                    | 1.45             | 2.45    | 7,500         |
|                           |          | 25C  | 1.55                    | 2.35             | 3.90    | 5,000         |
|                           |          | 30C  | 2.40                    | 3.65             | 5.50    | 3,800         |
|                           |          | 40C  | 4.40                    | 6.65             | 11.10   | 2,000         |

Specifications vary according to bore size. For exact figures, please enquire.

### ? Technical support

- Zero backlash, reliable one-piece construction
- Unique design maximises torsional stiffness without inducing high bearing loads
- Minimal velocity and positional fluctuations
- Over 50,000,000 test cycles at rated load and 80% offset without failure
- Maintenance free
- Recommended temperature range -80°C to +80°C
- Technical information - see page T8-1
- Installation information - see page T8-3





# 3 - 12 mm Bore

# Reli-a-Flex® Precision Couplings Reli-a-Grip™ Clamp

All dimensions in mm  
 General tolerances  $\pm 0.13$  mm  
 Material: Aluminium alloy grade 7075-T6  
 Finish: Alocrom 1000

**Associated Products**  
 Shafts: page 11-2  
 Bearings: page 12-1  
 Leadscrews: page 7-1  
 Intelligent motors: page 2-2

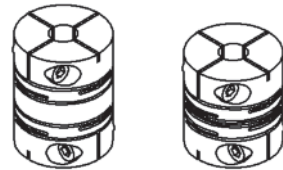
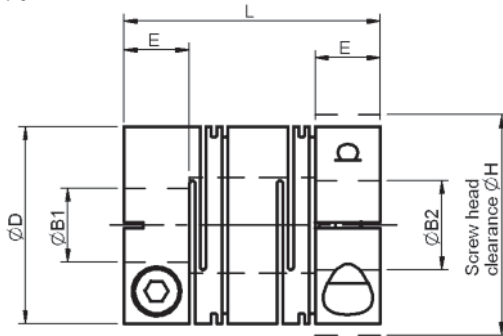

**RCL** (long type)    **RCS** (short type)

Couplings are chambered for ease of assembly and fitted with stainless steel screws.

## Part number selection table

| Example Part No:- <b>RCS A 20G - 8-5</b> |          |      |  | Dimensions (mm) |      |             |                 |              |
|--|----------|------|--|-----------------|------|-------------|-----------------|--------------|
| Basic Part No                            | Material | Size | Standard Bore Sizes<br>ØB1 and ØB2<br>(bore tolerance +0.020/-0.000) | O/D             |      | Length<br>L | Hub Length<br>E | Fitted Screw |
|  |          |      |  | ØD              | ØH   |             |                 |              |
| RCS<br>(short)                           | A        | 13G  | 3 4 5 6  | 13.0            | 14.5 | 16.80       | 5.00            | M1.6         |
|  |          | 16G  | 3 4 5 6 8  | 16.0            | 18.0 | 19.75       | 5.90            | M2           |
|  |          | 20G  | 4 5 6 8 10   | 20.0            | 21.8 | 21.50       | 6.60            | M2.5         |
|  |          | 25G  | 5 6 8 10 12  | 25.0            | 26.9 | 25.80       | 7.60            | M3           |
| RCL<br>(long)                            | A        | 13G  | 3 4 5 6  | 13.0            | 14.5 | 20.00       | 5.00            | M1.6         |
|  |          | 16G  | 3 4 5 6 8  | 16.0            | 18.0 | 23.50       | 5.90            | M2           |
|  |          | 20G  | 4 5 6 8 10   | 20.0            | 21.8 | 26.00       | 6.60            | M2.5         |
|  |          | 25G  | 5 6 8 10 12  | 25.0            | 26.9 | 34.00       | 7.60            | M3           |

Maximum shaft intrusion when fitted = E+2 mm.  
 Note: bores may be left unalocromed.

### **i** Product options

- Alternative bore sizes
- Imperial bores
- Alternative materials
- Electrically insulated
- Custom designs - see page 8-16
- Product overview - see pages 8-2 to 8-7



### Technical specification

| Basic Part No | Material | Size | Torsional <sup>1</sup> Stiffness Nm/rad | Radial Compliance microns/N | Misalignment |             |          | Max Inertia gcm <sup>2</sup> | Max Mass g |
|---------------|----------|------|---|-----------------------------|--------------|-------------|----------|------------------------------|------------|
|               |          |      |   |                             | Parallel mm  | Angular deg | Axial mm |                              |            |
| RCS (short)   | A        | 13G  | 45.00                                   | 29.2                        | ±0.08        | ±2.5        | ±0.30    | 1.0                          | 4.4        |
|               |          | 16G  | 70.00                                   | 28.9                        | ±0.10        | ±2.5        | ±0.40    | 2.9                          | 8.6        |
|               |          | 20G  | 115.00                                  | 23.4                        | ±0.12        | ±3.0        | ±0.50    | 7.9                          | 14.9       |
|               |          | 25G  | 182.00                                  | 20.0                        | ±0.16        | ±3.0        | ±0.70    | 23.0                         | 27.5       |
| RCL (long)    | A        | 13G  | 53.50                                   | 64.3                        | ±0.15        | ±2.5        | ±0.30    | 1.2                          | 5.5        |
|               |          | 16G  | 84.00                                   | 65.1                        | ±0.20        | ±2.5        | ±0.40    | 3.3                          | 10.6       |
|               |          | 20G  | 139.00                                  | 62.0                        | ±0.25        | ±3.0        | ±0.50    | 9.0                          | 18.7       |
|               |          | 25G  | 227.00                                  | 82.2                        | ±0.40        | ±3.0        | ±0.70    | 31.0                         | 38.5       |

Specifications vary according to bore size. For exact figures, please enquire.

<sup>1</sup> Typical torsional stiffness.

Couplings and Collars

### Torque and speed capacity

| Basic Part No             | Material | Size | Typical Torque Capacity |                  |         | Max Speed rpm |
|---------------------------|----------|------|-------------------------|------------------|---------|---------------|
|                           |          |      | Reversing Nm            | Non Reversing Nm | Peak Nm |               |
| RCS (short) or RCL (long) | A        | 13G  | 0.45                    | 0.60             | 0.70    | 12,000        |
|                           |          | 16G  | 0.75                    | 1.15             | 1.65    | 10,000        |
|                           |          | 20G  | 1.30                    | 1.95             | 3.25    | 7,500         |
|                           |          | 25G  | 2.05                    | 3.10             | 5.20    | 5,000         |

Specifications vary according to bore size. For exact figures, please enquire.

### ? Technical support

- Zero backlash, reliable one-piece construction
- Unique design maximises torsional stiffness without inducing high bearing loads
- Minimal velocity and positional fluctuations
- Over 50,000,000 test cycles at rated load and 80% offset without failure
- Maintenance free
- Recommended temperature range -80°C to +80°C
- Technical information - see [page T8-1](#)
- Installation information - see [page T8-3](#)





## Bespoke designs

The Reli-a-Flex® coupling can be customised to suit individual applications. For example, special interfaces can be incorporated into the design to allow easier interaction between the coupling and other components within the assembly. Alternative materials such as PEEK polymer and other plastics are available.

Reliance's design engineers can predict the achievable performance of Reli-a-Flex® confidently when provided with details of the allowable space envelope.

Please contact us to discuss your requirements.

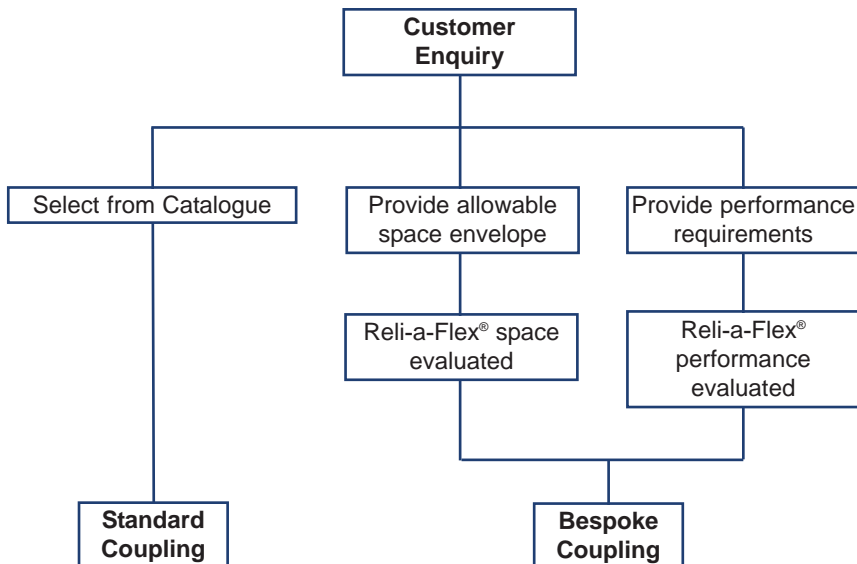





## Stocked range of Reli-a-Flex® couplings

The range of couplings below is held in stock and available on short delivery at reduced prices. It is subject to change from time to time, please visit our website at [www.reliance.co.uk/shop](http://www.reliance.co.uk/shop) for the latest details.

### Long type

#### Size 6

RCLA6-1.5-1.5

RCLA6-3-1.5

#### Size 8

RCLA8-2-2

RCLA8-3-3

#### Size 10

RCLA10-0.250-0.250

RCLA10-5-5

#### Size 13

RCLA13-0.250-0.250

RCLA13-4-4

RCLA13-6-5

RCLA13C-4-2

RCLA13C-4-4

RCLA13C-6-6

#### Size 16

RCLA16C-4-4

RCLA16C-5-4

RCLA16C-6-6

#### Size 20

RCLA20C-6-6

RCLA20C-8-8

RCLA20C-10-10

RCLA20C-0.250-0.250

RCLA20C-0.250-5

RCLA20C-0.250-6

#### Size 25

RCLA25C-6-6

RCLA25C-8-8

RCLA25C-10-10

RCLA25C-0.250-0.250

RCLA25C-0.375-0.375

RCLA25C-0.500-0.500

### Short type

#### Size 6

RCSA6-1.5-1.5

RCSA6-3-1.5

#### Size 8

RCSA8-2-2

RCSA8-3-3

#### Size 10

RCSA10-5-3

RCSA10-5-5

#### Size 13

RCSA13-4-4

RCSA13-5-3

RCSA13-0.250-0.250

RCSA13C-3-3

RCSA13C-5-5

#### Size 16

RCSA16C-6-6

RCSA16C-0.250-5

#### Size 20

RCSA20C-6-5

RCSA20C-6-6

RCSA20C-8-8

RCSA20C-10-10

#### Size 25

RCSA25C-6-5

RCSA25C-6-6

RCSA25C-8-6

RCSA25C-8-8



## 3 - 16 mm Bore

# Bellows Couplings Set Screw Hub

All dimensions in mm  
General tolerances  $\pm 0.13$  mm

**Associated Products**  
Shafts: page 11-2  
Bearings: page 12-1  
Leadscrews: page 7-1  
Intelligent motors: page 2-2

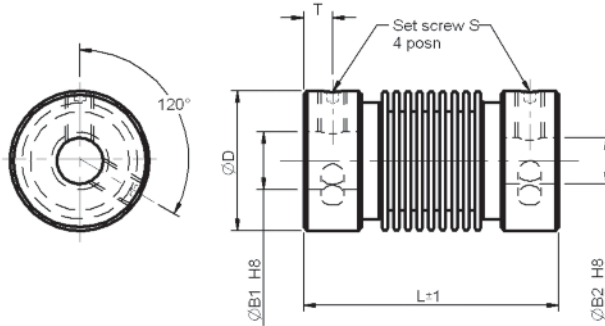

| H8        |           |
|-----------|-----------|
| Bore Size | Tolerance |
| 3         | +0.014    |
| 4         | +0.018    |
| 5         |           |
| 6         |           |
| 8         | +0.022    |
| 10        |           |
| 12        | +0.027    |
| 14        |           |
| 16        |           |

Couplings  
and Collars

### Part number selection table

| Part Number      | Hub Material                | Bellows Material             | Bore | Bore | O/D<br>ØD | Length<br>L | Screw<br>Position<br>T | Screw<br>Thread<br>S |
|------------------|-----------------------------|------------------------------|------|------|-----------|-------------|------------------------|----------------------|
|                  |                             |                              | ØB1  | ØB2  |           |             |                        |                      |
| RBKBS-1222-03-03 | Brass<br>(Nickel<br>Plated) | Bronze<br>(Nickel<br>Plated) | 3    | 3    | 12        | 22          | 2.2                    | M2.5                 |
| RBKBS-1222-04-04 |                             |                              | 4    | 4    |           |             |                        |                      |
| RBKBS-1222-06-04 |                             |                              | 6    | 4    |           |             |                        |                      |
| RBKBS-1222-05-05 |                             |                              | 5    | 5    |           |             |                        |                      |
| RBKBS-1222-06-06 |                             |                              | 6    | 6    |           |             |                        |                      |
| RBKXS-1520-03-03 | Aluminium<br>(Anodised)     | Stainless<br>steel           | 3    | 3    | 15        | 20          | 2.0                    | M3                   |
| RBKXS-1520-04-04 |                             |                              | 4    | 4    |           |             |                        |                      |
| RBKXS-1520-05-04 |                             |                              | 5    | 4    |           |             |                        |                      |
| RBKXS-1520-05-05 |                             |                              | 5    | 5    |           |             |                        |                      |
| RBKXS-1520-06-06 |                             |                              | 6    | 6    |           |             |                        |                      |
| RBKXS-1522-03-03 | Aluminium<br>(Anodised)     | Stainless<br>steel           | 3    | 3    | 15        | 22          | 2.0                    | M3                   |
| RBKXS-1522-04-04 |                             |                              | 4    | 4    |           |             |                        |                      |
| RBKXS-1522-05-04 |                             |                              | 5    | 4    |           |             |                        |                      |
| RBKXS-1522-05-05 |                             |                              | 5    | 5    |           |             |                        |                      |
| RBKXS-1522-06-06 |                             |                              | 6    | 6    |           |             |                        |                      |
| RBKXS-1525-03-03 | Aluminium<br>(Anodised)     | Stainless<br>steel           | 3    | 3    | 15        | 25          | 2.0                    | M3                   |
| RBKXS-1525-04-04 |                             |                              | 4    | 4    |           |             |                        |                      |
| RBKXS-1525-05-04 |                             |                              | 5    | 4    |           |             |                        |                      |
| RBKXS-1525-05-05 |                             |                              | 5    | 5    |           |             |                        |                      |
| RBKXS-1525-06-06 |                             |                              | 6    | 6    |           |             |                        |                      |
| RBKXS-1924-04-04 | Aluminium<br>(Anodised)     | Stainless<br>steel           | 4    | 4    | 19        | 24          | 2.0                    | M3                   |
| RBKXS-1924-05-05 |                             |                              | 5    | 5    |           |             |                        |                      |
| RBKXS-1924-06-06 |                             |                              | 6    | 6    |           |             |                        |                      |
| RBKXS-1924-08-08 |                             |                              | 8    | 8    |           |             |                        |                      |
| RBKXS-1924-10-10 |                             |                              | 10   | 10   |           |             |                        |                      |



### Part number selection table continued

| Part Number      | Hub Material         | Bellows Material | Bore | Bore | O/D | Length | Screw Position | Screw Thread |
|------------------|----------------------|------------------|------|------|-----|--------|----------------|--------------|
|                  |                      |                  | ØB1  | ØB2  | ØD  | L      | T              | S            |
| RBKXS-2029-04-04 | Aluminium (Anodised) | Stainless steel  | 4    | 4    | 20  | 29     | 3.2            | M4           |
| RBKXS-2029-06-04 |                      |                  | 6    | 4    |     |        |                |              |
| RBKXS-2029-06-06 |                      |                  | 6    | 6    |     |        |                |              |
| RBKXS-2029-10-06 |                      |                  | 10   | 6    |     |        |                |              |
| RBKXS-2029-08-08 |                      |                  | 8    | 8    |     |        |                |              |
| RBKXS-2029-10-10 |                      |                  | 10   | 10   |     |        |                |              |
| RBKXS-2029-12-10 |                      |                  | 12   | 10   |     |        |                |              |
| RBKXS-2029-12-12 | 12                   | 12               |      |      |     |        |                |              |
| RBKXS-2035-04-04 | Aluminium (Anodised) | Stainless steel  | 4    | 4    | 20  | 35     | 3.2            | M4           |
| RBKXS-2035-06-04 |                      |                  | 6    | 4    |     |        |                |              |
| RBKXS-2035-06-06 |                      |                  | 6    | 6    |     |        |                |              |
| RBKXS-2035-10-06 |                      |                  | 10   | 6    |     |        |                |              |
| RBKXS-2035-08-08 |                      |                  | 8    | 8    |     |        |                |              |
| RBKXS-2035-10-10 |                      |                  | 10   | 10   |     |        |                |              |
| RBKXS-2035-12-10 | 12                   | 10               |      |      |     |        |                |              |
| RBKXS-2526-06-06 | Aluminium (Anodised) | Stainless steel  | 6    | 6    | 25  | 26     | 2.8            | M4           |
| RBKXS-2526-08-08 |                      |                  | 8    | 8    |     |        |                |              |
| RBKXS-2526-10-10 |                      |                  | 10   | 10   |     |        |                |              |
| RBKXS-2526-12-12 |                      |                  | 12   | 12   |     |        |                |              |
| RBKXS-2526-14-14 |                      |                  | 14   | 14   |     |        |                |              |
| RBKXS-2526-16-16 |                      |                  | 16   | 16   |     |        |                |              |

Couplings and Collars

### Technical specifications

| Size Ref | Max Speed<br>min <sup>-1</sup> | Max Torque<br>Ncm | Misalignment |             |                | Torsional Stiffness<br>Nm/rad | Radial Stiffness<br>N/mm | Moment of Inertia<br>gcm <sup>2</sup> | Max Screw Torque<br>Ncm | Approx Weight<br>g |
|----------|--------------------------------|-------------------|--------------|-------------|----------------|-------------------------------|--------------------------|---------------------------------------|-------------------------|--------------------|
|          |                                |                   | Radial<br>mm | Axial<br>mm | Angular<br>deg |                               |                          |                                       |                         |                    |
| 1222     | 10,000                         | 15                | ±0.20        | ±0.40       | ±2.5           | 45                            | 30                       | 1.8                                   | 50                      | 8.0                |
| 1520     |                                | 40                | ±0.20        | ±0.40       | ±3.0           | 90                            | 40                       | 2.0                                   | 70                      | 6.0                |
| 1522     |                                | 40                | ±0.25        | ±0.45       | ±4.0           | 85                            | 20                       | 2.1                                   | 70                      | 6.5                |
| 1525     |                                | 40                | ±0.30        | ±0.50       | ±4.0           | 70                            | 15                       | 2.3                                   | 70                      | 7.0                |
| 1924     |                                | 80                | ±0.25        | ±0.40       | ±4.0           | 150                           | 25                       | 7.0                                   | 70                      | 10.0               |
| 2029     |                                | 80                | ±0.25        | ±0.40       | ±4.0           | 150                           | 25                       | 8.0                                   | 150                     | 15.0               |
| 2035     |                                | 80                | ±0.30        | ±0.50       | ±4.0           | 140                           | 10                       | 9.0                                   | 150                     | 16.0               |
| 2526     |                                | 200               | ±0.30        | ±0.40       | ±4.0           | 220                           | 45                       | 19.0                                  | 100                     | 17.5               |

### Technical support

- Zero backlash
- High torsional stiffness and low bearing loads
- Complete absorption of eccentricity, angularity and end play by spring action of the bellows
- Maintenance free
- Recommended temperature range -30°C to +120°C
- Product overview - see pages 8-2 to 8-7
- Technical information - see page T8-1





# 3 - 16 mm Bore

# Bellows Couplings Clamp Hub

All dimensions in mm  
General tolerances  $\pm 0.13$  mm

**Associated Products**  
Shafts: page 11-2  
Bearings: page 12-1  
Leadscrews: page 7-1  
Intelligent motors: page 2-2

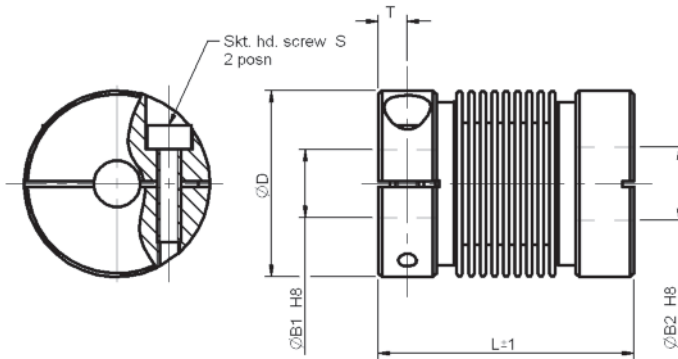

| H8        |           |
|-----------|-----------|
| Bore Size | Tolerance |
| 3         | +0.014    |
| 4         |           |
| 5         | +0.018    |
| 6         |           |
| 8         | +0.022    |
| 10        |           |
| 12        | +0.027    |
| 14        |           |
| 16        |           |

## Part number selection table

| Part Number      | Hub Material         | Bellows Material | Bore | Bore | O/D | Length L | Screw Position T | Screw Thread S |
|------------------|----------------------|------------------|------|------|-----|----------|------------------|----------------|
|                  |                      |                  | ØB1  | ØB2  | ØD  |          |                  |                |
| RBKXX-1622-03-03 | Aluminium (Anodised) | Stainless steel  | 3    | 3    | 16  | 22       | 2.3              | M2             |
| RBKXX-1622-04-04 |                      |                  | 4    | 4    |     |          |                  |                |
| RBKXX-1622-05-04 |                      |                  | 5    | 4    |     |          |                  |                |
| RBKXX-1622-06-04 |                      |                  | 6    | 4    |     |          |                  |                |
| RBKXX-1622-05-05 |                      |                  | 5    | 5    |     |          |                  |                |
| RBKXX-1622-06-06 |                      |                  | 6    | 6    |     |          |                  |                |
| RBKXX-1624-03-03 | Aluminium (Anodised) | Stainless steel  | 3    | 3    | 16  | 24       | 2.3              | M2             |
| RBKXX-1624-06-03 |                      |                  | 6    | 3    |     |          |                  |                |
| RBKXX-1624-04-04 |                      |                  | 4    | 4    |     |          |                  |                |
| RBKXX-1624-05-04 |                      |                  | 5    | 4    |     |          |                  |                |
| RBKXX-1624-06-04 |                      |                  | 6    | 4    |     |          |                  |                |
| RBKXX-1624-05-05 |                      |                  | 5    | 5    |     |          |                  |                |
| RBKXX-1624-06-06 | 6                    | 6                |      |      |     |          |                  |                |
| RBKXX-1627-03-03 | Aluminium (Anodised) | Stainless steel  | 3    | 3    | 16  | 27       | 2.3              | M2             |
| RBKXX-1627-06-03 |                      |                  | 6    | 3    |     |          |                  |                |
| RBKXX-1627-04-04 |                      |                  | 4    | 4    |     |          |                  |                |
| RBKXX-1627-05-04 |                      |                  | 5    | 4    |     |          |                  |                |
| RBKXX-1627-05-05 |                      |                  | 5    | 5    |     |          |                  |                |
| RBKXX-1627-06-06 |                      |                  | 6    | 6    |     |          |                  |                |
| RBKXX-2129-06-06 | Aluminium (Anodised) | Stainless steel  | 6    | 6    | 21  | 29       | 3.0              | M2.5           |
| RBKXX-2129-10-06 |                      |                  | 10   | 6    |     |          |                  |                |
| RBKXX-2129-08-08 |                      |                  | 8    | 8    |     |          |                  |                |
| RBKXX-2129-10-10 |                      |                  | 10   | 10   |     |          |                  |                |



### Part number selection table continued

| Part Number      | Hub Material            | Bellows Material | Bore |     | O/D<br>ØD | Length<br>L | Screw Position<br>T | Screw Thread<br>S |
|------------------|-------------------------|------------------|------|-----|-----------|-------------|---------------------|-------------------|
|                  |                         |                  | ØB1  | ØB2 |           |             |                     |                   |
| RBKXX-2135-06-06 | Aluminium<br>(Anodised) | Stainless steel  | 6    | 6   | 21        | 35          | 3.0                 | M2.5              |
| RBKXX-2135-10-06 |                         |                  | 10   | 6   |           |             |                     |                   |
| RBKXX-2135-08-08 |                         |                  | 8    | 8   |           |             |                     |                   |
| RBKXX-2135-10-10 |                         |                  | 10   | 10  |           |             |                     |                   |
| RBKXX-2429-12-06 | Aluminium<br>(Anodised) | Stainless steel  | 12   | 6   | 24        | 29          | 3.0                 | M2.5              |
| RBKXX-2429-12-10 |                         |                  | 12   | 10  |           |             |                     |                   |
| RBKXX-2429-12-12 |                         |                  | 12   | 12  |           |             |                     |                   |
| RBKXX-2435-12-06 | Aluminium<br>(Anodised) | Stainless steel  | 12   | 6   | 24        | 35          | 3.0                 | M2.5              |
| RBKXX-2435-12-10 |                         |                  | 12   | 10  |           |             |                     |                   |
| RBKXX-2435-12-12 |                         |                  | 12   | 12  |           |             |                     |                   |
| RBKXX-3030-12-10 | Aluminium<br>(Anodised) | Stainless steel  | 12   | 10  | 30        | 30          | 3.0                 | M3                |
| RBKXX-3030-12-12 |                         |                  | 12   | 12  |           |             |                     |                   |
| RBKXX-3030-14-14 |                         |                  | 14   | 14  |           |             |                     |                   |
| RBKXX-3030-16-16 |                         |                  | 16   | 16  |           |             |                     |                   |

### Technical specifications

| Size Ref | Max Speed<br>min <sup>-1</sup> | Max Torque<br>Ncm | Misalignment |             |                | Torsional Stiffness<br>Nm/rad | Radial Stiffness<br>N/mm | Moment of Inertia<br>gcm <sup>2</sup> | Max Screw Torque<br>Ncm | Approx Weight<br>g |
|----------|--------------------------------|-------------------|--------------|-------------|----------------|-------------------------------|--------------------------|---------------------------------------|-------------------------|--------------------|
|          |                                |                   | Radial<br>mm | Axial<br>mm | Angular<br>deg |                               |                          |                                       |                         |                    |
| 1622     | 10,000                         | 40                | ±0.20        | ±0.40       | ±3.0           | 90                            | 40                       | 2.1                                   | 50                      | 6.0                |
| 1624     |                                | 40                | ±0.25        | ±0.45       | ±4.0           | 85                            | 20                       | 2.2                                   | 50                      | 6.5                |
| 1627     |                                | 40                | ±0.30        | ±0.50       | ±4.0           | 70                            | 15                       | 2.6                                   | 50                      | 7.0                |
| 2129     |                                | 80                | ±0.25        | ±0.40       | ±4.0           | 150                           | 25                       | 9.0                                   | 100                     | 15.0               |
| 2135     |                                | 80                | ±0.30        | ±0.50       | ±4.0           | 140                           | 10                       | 9.5                                   | 100                     | 16.0               |
| 2429     |                                | 80                | ±0.25        | ±0.40       | ±4.0           | 150                           | 25                       | 15.0                                  | 100                     | 17.0               |
| 2435     |                                | 80                | ±0.30        | ±0.50       | ±4.0           | 140                           | 10                       | 15.2                                  | 100                     | 18.0               |
| 3030     |                                | 200               | ±0.30        | ±0.40       | ±4.0           | 220                           | 45                       | 37.0                                  | 100                     | 31.0               |

### ? Technical support

- Zero backlash
- High torsional stiffness and low bearing loads
- Complete absorption of eccentricity, angularity and end play by spring action of the bellows
- Maintenance free
- Recommended temperature range -30°C to +120°C
- Technical information - see page T8-1
- Product overview - see pages 8-2 to 8-7





## 2 - 12 mm Bore

# Nickel Bellows Couplings Set Screw Hub

All dimensions in mm  
General tolerances  $\pm 0.13$  mm

**Associated Products**  
Shafts: page 11-2  
Bearings: page 12-1  
Leadscrews: page 7-1  
Intelligent motors: page 2-2

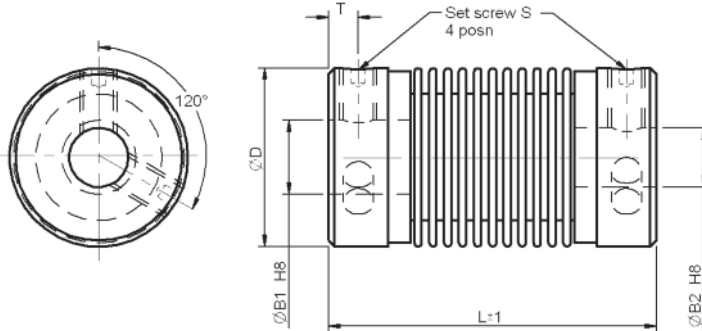

| H8        |           |
|-----------|-----------|
| Bore Size | Tolerance |
| 2         | +0.014    |
| 3         |           |
| 4         |           |
| 6         | +0.018    |
| 8         | +0.022    |
| 10        |           |
| 12        |           |
| 12        | +0.027    |

Couplings  
and Collars

### Part number selection table

| Part Number      | Hub Material         | Bellows Material | Bore | Bore | O/D | Length | Screw Position | Screw Thread |
|------------------|----------------------|------------------|------|------|-----|--------|----------------|--------------|
|                  |                      |                  | ØB1  | ØB2  |     |        |                |              |
| RBKNS-1223-02-02 | Stainless steel      | Nickel           | 2    | 2    | 12  | 23     | 2.0            | M2.5         |
| RBKNS-1223-03-02 |                      |                  | 3    | 2    |     |        |                |              |
| RBKNS-1223-03-03 |                      |                  | 3    | 3    |     |        |                |              |
| RBKNS-1223-04-04 |                      |                  | 4    | 4    |     |        |                |              |
| RBKNS-1223-06-04 |                      |                  | 6    | 4    |     |        |                |              |
| RBKNS-1223-06-06 | 6                    | 6                |      |      |     |        |                |              |
| RBKNS-1730-04-04 | Aluminium (Anodised) | Nickel           | 4    | 4    | 17  | 31     | 2.0            | M3           |
| RBKNS-1730-06-04 |                      |                  | 6    | 4    |     |        |                |              |
| RBKNS-1730-06-06 |                      |                  | 6    | 6    |     |        |                |              |
| RBKNS-1730-10-06 |                      |                  | 10   | 6    |     |        |                |              |
| RBKNS-1730-08-08 |                      |                  | 8    | 8    |     |        |                |              |
| RBKNS-1730-10-10 | 10                   | 10               |      |      |     |        |                |              |
| RBKNS-2533-06-06 | Aluminium (Anodised) | Nickel           | 6    | 6    | 25  | 33     | 2.3            | M3           |
| RBKNS-2533-10-06 |                      |                  | 10   | 6    |     |        |                |              |
| RBKNS-2533-12-06 |                      |                  | 12   | 6    |     |        |                |              |
| RBKNS-2533-08-08 |                      |                  | 8    | 8    |     |        |                |              |
| RBKNS-2533-10-10 |                      |                  | 10   | 10   |     |        |                |              |
| RBKNS-2533-12-12 | 12                   | 12               |      |      |     |        |                |              |

### Technical specifications

| Size Ref | Max Speed         | Max Torque | Misalignment |       |         | Torsional Stiffness | Radial Stiffness | Moment of Inertia | Max Screw Torque | Approx Weight |
|----------|-------------------|------------|--------------|-------|---------|---------------------|------------------|-------------------|------------------|---------------|
|          |                   |            | Radial       | Axial | Angular |                     |                  |                   |                  |               |
|          | min <sup>-1</sup> | Ncm        | mm           | mm    | deg     | Nm/rad              | N/mm             | gcm <sup>2</sup>  | Ncm              | g             |
| 1223     | 10,000            | 13         | ±0.54        | ±2.29 | ±15     | 28                  | 4.2              | 1.85              | 60               | 10.0          |
| 1730     |                   | 39         | ±0.72        | ±3.09 | ±14     | 70                  | 3.0              | 3.81              | 80               | 10.0          |
| 2533     |                   | 200        | ±0.46        | ±2.77 | ±8      | 210                 | 29.0             | 16.10             | 80               | 19.5          |

# Nickel Bellows Couplings Clamp Hub

3 - 12 mm Bore



**Associated Products**  
 Shafts: page 11-2  
 Bearings: page 12-1  
 Leadscrews: page 7-1  
 Intelligent motors: page 2-2

All dimensions in mm  
 General tolerances  $\pm 0.13$  mm

| H8        |           |
|-----------|-----------|
| Bore Size | Tolerance |
| 3         | +0.014    |
| 4         |           |
| 6         | +0.018    |
| 8         |           |
| 10        | +0.022    |
| 12        | +0.027    |

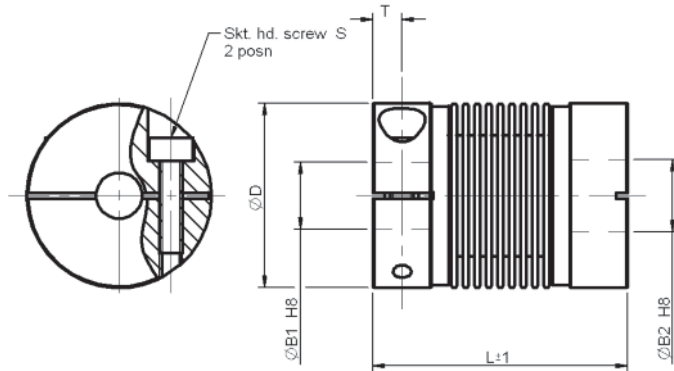

## Part number selection table

| Part Number      | Hub Material            | Bellows Material | Bore | Bore | O/D  | Length | Screw Position | Screw Thread |
|------------------|-------------------------|------------------|------|------|------|--------|----------------|--------------|
|                  |                         |                  | ØB1  | ØB2  | ØD   | L      | T              | S            |
| RBKNC-1733-03-03 | Aluminium<br>(Anodised) | Nickel           | 3    | 3    | 16.3 | 33     | 2.5            | M2           |
| RBKNC-1733-04-04 |                         |                  | 4    | 4    |      |        |                |              |
| RBKNC-1733-06-04 |                         |                  | 6    | 4    |      |        |                |              |
| RBKNC-1733-06-06 |                         |                  | 6    | 6    |      |        |                |              |
| RBKNC-2537-06-06 | Aluminium<br>(Anodised) | Nickel           | 6    | 6    | 25   | 37     | 2.8            | M2.5         |
| RBKNC-2537-10-06 |                         |                  | 10   | 6    |      |        |                |              |
| RBKNC-2537-08-08 |                         |                  | 8    | 8    |      |        |                |              |
| RBKNC-2537-10-10 |                         |                  | 10   | 10   |      |        |                |              |
| RBKNC-2537-12-12 |                         |                  | 12   | 12   |      |        |                |              |

## Technical specifications

| Size Ref | Max Speed<br>min <sup>-1</sup> | Max Torque<br>Ncm | Misalignment |             |                | Torsional Stiffness<br>Nm/rad | Radial Stiffness<br>N/mm | Moment of Inertia<br>gcm <sup>2</sup> | Max Screw Torque<br>Ncm | Approx Weight<br>g |
|----------|--------------------------------|-------------------|--------------|-------------|----------------|-------------------------------|--------------------------|---------------------------------------|-------------------------|--------------------|
|          |                                |                   | Radial<br>mm | Axial<br>mm | Angular<br>deg |                               |                          |                                       |                         |                    |
| 1733     | 10,000                         | 39                | $\pm 0.72$   | $\pm 3.09$  | $\pm 14$       | 70                            | 3.0                      | 4.89                                  | 35                      | 11.5               |
| 2537     |                                | 200               | $\pm 0.46$   | $\pm 2.77$  | $\pm 8$        | 210                           | 29.0                     | 25.40                                 | 66                      | 28.5               |

## Technical support

- Zero backlash
- High torsional stiffness and low bearing loads
- Complete absorption of eccentricity, angularity and end play by spring action of the bellows
- Maintenance free
- Recommended temperature range -30°C to +120°C
- Technical information - see page T8-1
- Product overview - see pages 8-2 to 8-7



Contact us for product information, design support and custom solutions  
 sales@reliance.co.uk +44 (0) 1484 601002 www.reliance.co.uk



## 2 - 6 mm Bore

# Flexible Disc Spring Couplings Set Screw Hub

All dimensions in mm  
General tolerances  $\pm 0.13$  mm

**Associated Products**  
Shafts: page 11-2  
Bearings: page 12-1  
Leadscrews: page 7-1  
Intelligent motors: page 2-2

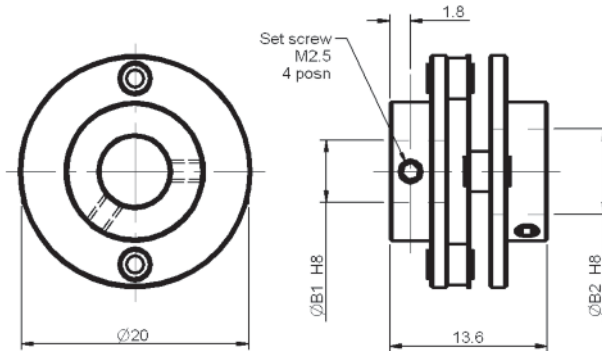

| H8        |           |
|-----------|-----------|
| Bore Size | Tolerance |
| 2         | +0.014    |
| 4         | +0.018    |
| 6         |           |

Couplings  
and Collars

### Part number selection table

| Part Number      | Hub Material            | Disc Springs Material | Bore |     |
|------------------|-------------------------|-----------------------|------|-----|
|                  |                         |                       | ØB1  | ØB2 |
| RFSXS-2014-02-02 | Aluminium<br>(Anodised) | Stainless<br>steel    | 2    | 2   |
| RFSXS-2014-04-02 |                         |                       | 4    | 2   |
| RFSXS-2014-04-04 |                         |                       | 4    | 4   |
| RFSXS-2014-06-06 |                         |                       | 6    | 6   |

### Technical specifications

| Size Ref | Max Speed<br>min <sup>-1</sup> | Max Torque<br>Ncm | Misalignment |             |                | Torsional Stiffness<br>Nm/rad | Radial Stiffness<br>N/mm | Moment of Inertia<br>gcm <sup>2</sup> | Max Screw Torque<br>Ncm | Approx Weight<br>g |
|----------|--------------------------------|-------------------|--------------|-------------|----------------|-------------------------------|--------------------------|---------------------------------------|-------------------------|--------------------|
|          |                                |                   | Radial<br>mm | Axial<br>mm | Angular<br>deg |                               |                          |                                       |                         |                    |
| 2014     | 10,000                         | 50                | -            | ±0.3        | ±2.5           | 100                           | -                        | 2.6                                   | 60                      | 5.0                |

### ? Technical support

- Zero backlash
- High torsional stiffness
- Maintenance free
- Recommended temperature range -30°C to +120°C
- Vibration isolation
- Technical information - see [page T8-1](#)
- Product overview - see [pages 8-2 to 8-7](#)





# Flexible Disc Spring Couplings Set Screw Hub

2 - 6 mm Bore



**Associated Products**  
 Shafts: page 11-2  
 Bearings: page 12-1  
 Leadscrews: page 7-1  
 Intelligent motors: page 2-2

All dimensions in mm  
 General tolerances  $\pm 0.13$  mm

| H8        |           |
|-----------|-----------|
| Bore Size | Tolerance |
| 2         | +0.014    |
| 4         | +0.018    |
| 6         | +0.018    |

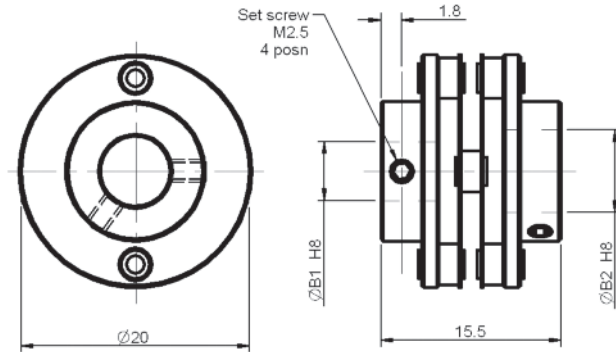

## Part number selection table

| Part Number      | Hub Material            | Disc Springs Material | Bore |     |
|------------------|-------------------------|-----------------------|------|-----|
|                  |                         |                       | ØB1  | ØB2 |
| RFSXS-2016-02-02 | Aluminium<br>(Anodised) | Stainless<br>steel    | 2    | 2   |
| RFSXS-2016-04-02 |                         |                       | 4    | 2   |
| RFSXS-2016-04-04 |                         |                       | 4    | 4   |
| RFSXS-2016-06-06 |                         |                       | 6    | 6   |

## Technical specifications

| Size Ref | Max Speed<br>min <sup>-1</sup> | Max Torque<br>Ncm | Misalignment |             |                | Torsional Stiffness<br>Nm/rad | Radial Stiffness<br>N/mm | Moment of Inertia<br>gcm <sup>2</sup> | Max Screw Torque<br>Ncm | Approx Weight<br>g |
|----------|--------------------------------|-------------------|--------------|-------------|----------------|-------------------------------|--------------------------|---------------------------------------|-------------------------|--------------------|
|          |                                |                   | Radial<br>mm | Axial<br>mm | Angular<br>deg |                               |                          |                                       |                         |                    |
| 2016     | 10,000                         | 50                | ±0.2         | ±0.4        | ±3.0           | 20                            | 125                      | 2.8                                   | 60                      | 6.0                |

## ? Technical support

- Zero backlash
- High torsional stiffness and low bearing loads
- Maintenance free
- Recommended temperature range -30°C to +120°C
- Vibration isolation
- Technical information - see [page T8-1](#)
- Product overview - see [pages 8-2 to 8-7](#)



Contact us for product information, design support and custom solutions  
[sales@reliance.co.uk](mailto:sales@reliance.co.uk) +44 (0) 1484 601002 [www.reliance.co.uk](http://www.reliance.co.uk)

8-25



## 2 - 4 mm Bore

# Flexible Disc Spring Couplings Clamp Hub

All dimensions in mm  
General tolerances  $\pm 0.13$  mm

**Associated Products**  
Shafts: page 11-2  
Bearings: page 12-1  
Leadscrews: page 7-1  
Intelligent motors: page 2-2

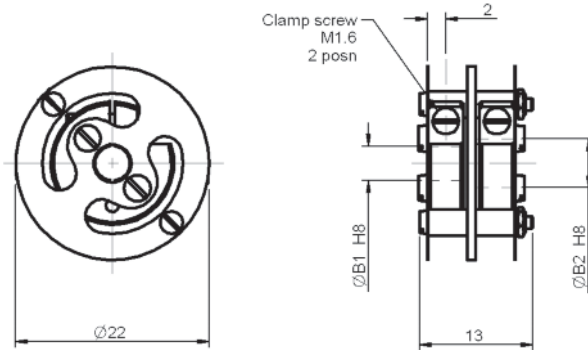

| H8        |           |
|-----------|-----------|
| Bore Size | Tolerance |
| 2         |           |
| 3         | +0.014    |
| 4         | +0.018    |

Couplings  
and Collars

### Part number selection table

| Part Number      | Hub Material        | Disc Springs Material | Bore             |                  |
|------------------|---------------------|-----------------------|------------------|------------------|
|                  |                     |                       | $\varnothing B1$ | $\varnothing B2$ |
| RFSXK-2213-02-02 | Nickel plated steel | Stainless steel       | 2                | 2                |
| RFSXK-2213-03-02 |                     |                       | 3                | 2                |
| RFSXK-2213-03-03 |                     |                       | 3                | 3                |
| RFSXK-2213-04-04 |                     |                       | 4                | 4                |

### Technical specifications

| Size Ref | Max Speed<br>$\text{min}^{-1}$ | Max Torque<br>Ncm | Misalignment |             |                | Torsional Stiffness<br>Nm/rad | Radial Stiffness<br>N/mm | Moment of Inertia<br>$\text{gcm}^2$ | Max Screw Torque<br>Ncm | Approx Weight<br>g |
|----------|--------------------------------|-------------------|--------------|-------------|----------------|-------------------------------|--------------------------|-------------------------------------|-------------------------|--------------------|
|          |                                |                   | Radial<br>mm | Axial<br>mm | Angular<br>deg |                               |                          |                                     |                         |                    |
| 2213     | 10,000                         | 20                | $\pm 0.3$    | $\pm 0.3$   | $\pm 2.0$      | 14                            | 3.0                      | 3.2                                 | 20                      | 9.5                |

### ? Technical support

- Zero backlash
- High torsional stiffness and low bearing loads
- Maintenance free
- Recommended temperature range  $-30^{\circ}\text{C}$  to  $+120^{\circ}\text{C}$
- Vibration isolation
- Technical information - see [page T8-1](#)
- Product overview - see [pages 8-2 to 8-7](#)

# Flexible Disc Spring Couplings Clamp Hub

3 - 8 mm Bore



**Associated Products**  
 Shafts: page 11-2  
 Bearings: page 12-1  
 Leadscrews: page 7-1  
 Intelligent motors: page 2-2

All dimensions in mm  
 General tolerances  $\pm 0.13$  mm

| H8        |           |
|-----------|-----------|
| Bore Size | Tolerance |
| 3         | +0.014    |
| 4         | +0.018    |
| 5         |           |
| 6         | +0.022    |
| 8         |           |

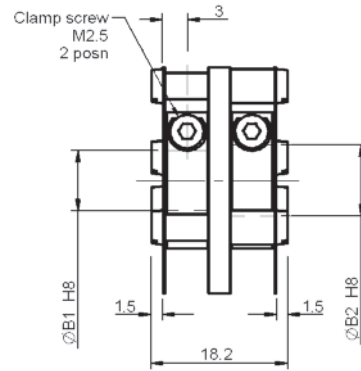
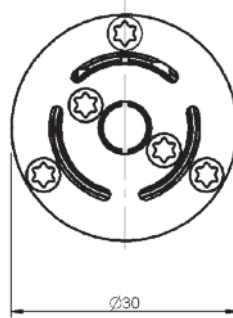

## Part number selection table

| Part Number      | Hub Material            | Disc Springs Material | Bore |     |
|------------------|-------------------------|-----------------------|------|-----|
|                  |                         |                       | ØB1  | ØB2 |
| RFSXK-3019-03-03 | Aluminium<br>(Anodised) | Stainless<br>steel    | 3    | 3   |
| RFSXK-3019-04-04 |                         |                       | 4    | 4   |
| RFSXK-3019-05-05 |                         |                       | 5    | 5   |
| RFSXK-3019-06-05 |                         |                       | 6    | 5   |
| RFSXK-3019-06-06 |                         |                       | 6    | 6   |
| RFSXK-3019-08-06 |                         |                       | 8    | 6   |
| RFSXK-3019-10-08 |                         |                       | 10   | 8   |

## Technical specifications

| Size Ref | Max Speed<br>$\text{min}^{-1}$ | Max Torque<br>Ncm | Misalignment |             |                | Torsional Stiffness<br>Nm/rad | Radial Stiffness<br>N/mm | Moment of Inertia<br>$\text{gcm}^2$ | Max Screw Torque<br>Ncm | Approx Weight<br>g |
|----------|--------------------------------|-------------------|--------------|-------------|----------------|-------------------------------|--------------------------|-------------------------------------|-------------------------|--------------------|
|          |                                |                   | Radial<br>mm | Axial<br>mm | Angular<br>deg |                               |                          |                                     |                         |                    |
| 3019     | 12,000                         | 80                | $\pm 0.4$    | $\pm 0.4$   | $\pm 3.0$      | 150                           | 6                        | 19                                  | 80                      | 16                 |

## Technical support

- Zero backlash
- High torsional stiffness and low bearing loads
- Maintenance free
- Recommended temperature range  $-30^{\circ}\text{C}$  to  $+120^{\circ}\text{C}$
- Vibration isolation
- Technical information - see page T8-1
- Product overview - see pages 8-2 to 8-7



Contact us for product information, design support and custom solutions  
 sales@reliance.co.uk +44 (0) 1484 601002 www.reliance.co.uk

8-27

Couplings  
and Collars



# 6 - 14 mm Bore

# Flexible Disc Spring Couplings Clamp Hub

All dimensions in mm  
General tolerances  $\pm 0.13$  mm

**Associated Products**  
Shafts: page 11-2  
Bearings: page 12-1  
Leadscrews: page 7-1  
Intelligent motors: page 2-2

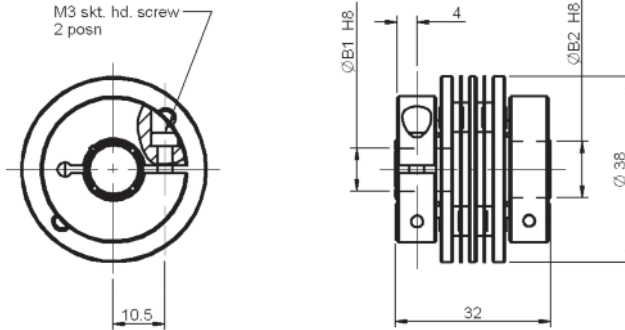

| H8        |           |
|-----------|-----------|
| Bore Size | Tolerance |
| 6         | +0.018    |
| 9.53      | +0.022    |
| 10        |           |
| 12        | +0.027    |
| 14        |           |

## Part number selection table

| Part Number      | Hub Material         | Disc Springs Material | Bore |      |
|------------------|----------------------|-----------------------|------|------|
|                  |                      |                       | ØB1  | ØB2  |
| RFSXK-3832-06-06 | Aluminium (Anodised) | Stainless steel       | 6    | 6    |
| RFSXK-3832-95-95 |                      |                       | 9.53 | 9.53 |
| RFSXK-3832-10-10 |                      |                       | 10   | 10   |
| RFSXK-3832-12-10 |                      |                       | 12   | 10   |
| RFSXK-3832-12-12 |                      |                       | 12   | 12   |
| RFSXK-3832-14-12 |                      |                       | 14   | 12   |
| RFSXK-3832-14-14 |                      |                       | 14   | 14   |

## Technical specifications

| Size Ref | Max Speed         | Max Torque | Misalignment |       |         | Torsional Stiffness | Radial Stiffness | Moment of Inertia | Max Screw Torque | Approx Weight |
|----------|-------------------|------------|--------------|-------|---------|---------------------|------------------|-------------------|------------------|---------------|
|          |                   |            | Radial       | Axial | Angular |                     |                  |                   |                  |               |
|          | min <sup>-1</sup> | Ncm        | mm           | mm    | deg     | Nm/rad              | N/mm             | gcm <sup>2</sup>  | Ncm              | g             |
| 3832     | 8,000             | 200        | ±0.3         | ±0.3  | ±2.5    | 250                 | 220              | 82                | 100              | 53            |

## Technical support

- Zero backlash
- High torsional stiffness and low bearing loads
- Maintenance free
- Recommended temperature range -30°C to +120°C
- Vibration isolation
- Suitable for high number of revolutions at high torque
- Technical information - see page T8-1
- Product overview - see pages 8-2 to 8-7



# Flexible Disc Spring Couplings Clamp Hub

6 - 14 mm Bore



**Associated Products**  
 Shafts: page 11-2  
 Bearings: page 12-1  
 Leadscrews: page 7-1  
 Intelligent motors: page 2-2

All dimensions in mm  
 General tolerances  $\pm 0.13$  mm

| H8        |           |
|-----------|-----------|
| Bore Size | Tolerance |
| 6         | +0.018    |
| 9.53      | +0.022    |
| 10        | +0.022    |
| 12        | +0.027    |
| 14        | +0.027    |

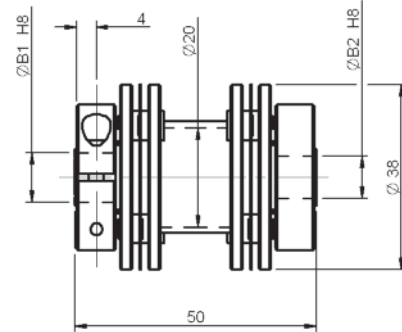
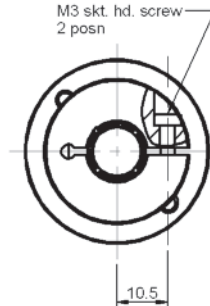

Couplings and Collars

## Part number selection table

| Part Number      | Hub Material         | Disc Springs Material | Bore |      |
|------------------|----------------------|-----------------------|------|------|
|                  |                      |                       | ØB1  | ØB2  |
| RFSXK-3850-06-06 | Aluminium (Anodised) | Stainless steel       | 6    | 6    |
| RFSXK-3850-95-95 |                      |                       | 9.53 | 9.53 |
| RFSXK-3850-10-10 |                      |                       | 10   | 10   |
| RFSXK-3850-12-10 |                      |                       | 12   | 10   |
| RFSXK-3850-12-12 |                      |                       | 12   | 12   |
| RFSXK-3850-14-12 |                      |                       | 14   | 12   |
| RFSXK-3850-14-14 |                      |                       | 14   | 14   |

## Technical specifications

| Size Ref | Max Speed<br>$\text{min}^{-1}$ | Max Torque<br>Ncm | Misalignment |             |                | Torsional Stiffness<br>Nm/rad | Radial Stiffness<br>N/mm | Moment of Inertia<br>$\text{gcm}^2$ | Max Screw Torque<br>Ncm | Approx Weight<br>g |
|----------|--------------------------------|-------------------|--------------|-------------|----------------|-------------------------------|--------------------------|-------------------------------------|-------------------------|--------------------|
|          |                                |                   | Radial<br>mm | Axial<br>mm | Angular<br>deg |                               |                          |                                     |                         |                    |
| 3850     | 8,000                          | 200               | $\pm 0.8$    | $\pm 0.8$   | $\pm 2.5$      | 250                           | 12                       | 106                                 | 100                     | 63                 |

## Technical support

- Zero backlash
- High torsional stiffness and low bearing loads
- Maintenance free
- Recommended temperature range  $-30^{\circ}\text{C}$  to  $+120^{\circ}\text{C}$
- Vibration isolation
- Suitable for high number of revolutions at high torque
- Technical information - see page T8-1
- Product overview - see pages 8-2 to 8-7



Contact us for product information, design support and custom solutions  
 sales@reliance.co.uk +44 (0) 1484 601002 www.reliance.co.uk



# 3 - 12 mm bore

# Oldham Couplings

All dimensions in mm  
 Hub material: Aluminium alloy  
 grade 2024 T351 or 7075 T651  
 Finish: Black sulphuric anodised  
 MIL-A-8625 Type II, class 2  
 Spacer material: Acetal or nylon 11

**Associated Products**  
 Shafts: page 11-2  
 Bearings: page 12-1  
 Leadscrews: page 7-1  
 Intelligent motors: page 2-2

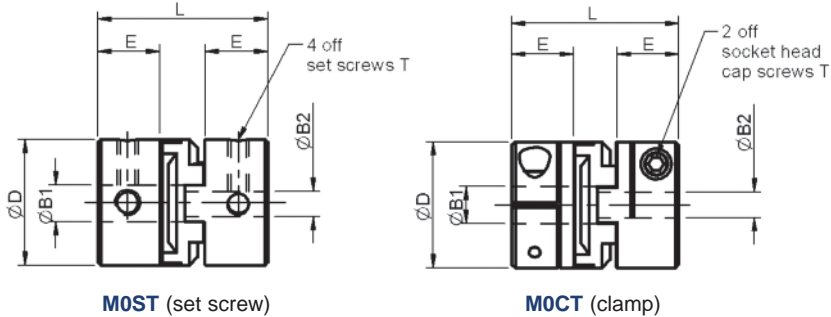

Couplings and Collars

## Part number selection table

| Example Part No:-   |                | M0ST AT - 13 - 3-3 |                                 |   |   |   |   |    | Dimensions (mm) |           |             |                 |                   |    |
|---------------------|----------------|--------------------|---------------------------------|---|---|---|---|----|-----------------|-----------|-------------|-----------------|-------------------|----|
| Basic Part No       | Disc Material  | Size               | Standard Bore Sizes ØB1 and ØB2 |   |   |   |   |    |                 | O/D<br>ØD | Length<br>L | Hub Length<br>E | Fitted Screw<br>T |    |
|                     |                |                    | (bore tolerance +0.050/-0.000)  |   |   |   |   |    |                 |           |             |                 |                   |    |
| M0ST<br>(set screw) | AT<br>(Acetal) | 13                 | 3                               | 4 | 5 | 6 |   |    |                 | 12.7      | 15.9        | 5.6             | M3                |    |
|                     |                | 19                 |                                 | 4 | 5 | 6 | 8 |    |                 | 19.1      | 22.2        | 7.6             | M3                |    |
|                     | NL<br>(Nylon)  | 25                 |                                 |   |   | 6 | 8 | 10 | 12              | 25.4      | 28.6        | 9.9             | M4                |    |
|                     |                | 33                 |                                 |   |   |   |   | 8  | 10              | 12        | 33.3        | 47.6            | 15.0              | M4 |
|                     |                | 41                 |                                 |   |   |   |   |    | 10              | 12        | 41.3        | 50.8            | 18.0              | M5 |
| M0CT<br>(clamp)     | AT<br>(Acetal) | 19                 |                                 | 4 | 5 | 6 | 8 |    |                 | 19.1      | 25.4        | 9.7             | M2.5              |    |
|                     |                | 25                 |                                 |   |   | 6 | 8 | 10 | 12              | 25.4      | 31.8        | 11.9            | M3                |    |
|                     | NL<br>(Nylon)  | 33                 |                                 |   |   |   | 8 | 10 | 12              | 33.3      | 47.6        | 15.0            | M3                |    |
|                     |                | 41                 |                                 |   |   |   |   |    | 10              | 12        | 41.3        | 50.8            | 18.0              | M4 |

Note: Oldham couplings sizes 13 and 19 use only two set screws 'T'

### **i** Product options

- Larger or alternative bore sizes
- Imperial bores
- Product overview - see pages 8-2 to 8-7





### Technical specifications

| Size Ref | Disc Material | Torsional Stiffness Deg/Nm | Torque Capacity |          | Misalignment |          |
|----------|---------------|----------------------------|-----------------|----------|--------------|----------|
|          |               |                            | Rated Nm        | Break Nm | Parallel mm  | Axial mm |
| 13       | AT            | 0.636                      | 0.68            | 3.9      | 0.10         | 0.05     |
|          | NL            | 2.560                      | 0.17            | 2.8      | 0.10         | 0.05     |
| 19       | AT            | 0.380                      | 2.25            | 10.5     | 0.20         | 0.10     |
|          | NL            | 1.240                      | 0.57            | 9.6      | 0.20         | 0.10     |
| 25       | AT            | 0.291                      | 4.75            | 19.0     | 0.20         | 0.10     |
|          | NL            | 1.110                      | 1.13            | 15.9     | 0.20         | 0.10     |
| 33       | AT            | 0.079                      | 8.00            | 39.5     | 0.20         | 0.15     |
|          | NL            | 0.460                      | 2.05            | 34.0     | 0.20         | 0.15     |
| 41       | AT            | 0.068                      | 14.75           | 54.5     | 0.25         | 0.15     |
|          | NL            | 0.330                      | 3.65            | 45.3     | 0.25         | 0.15     |

### ? Technical support

- Zero backlash with acetal disc
- High parallel misalignment capability
- Electrically insulated discs act as a mechanical fuse preventing damage to other components
- Temperature range:-
  - Acetal disc: -23°C to +65°C.
  - Nylon disc: -23°C to +54°C.
- Max speed: 4,500 rpm
- Acetal discs provide high torsional stiffness
- Nylon discs provide vibration and shock absorption
- Technical information - see page T8-1
- Installation information - see page T8-3





# 6 - 10 mm Bore

# Membrane Couplings Clamp Hub

All dimensions in mm  
General tolerances  $\pm 0.13$  mm

**Associated Products**  
Shafts: page 11-2  
Bearings: page 12-1  
Leadscrews: page 7-1  
Intelligent motors: page 2-2

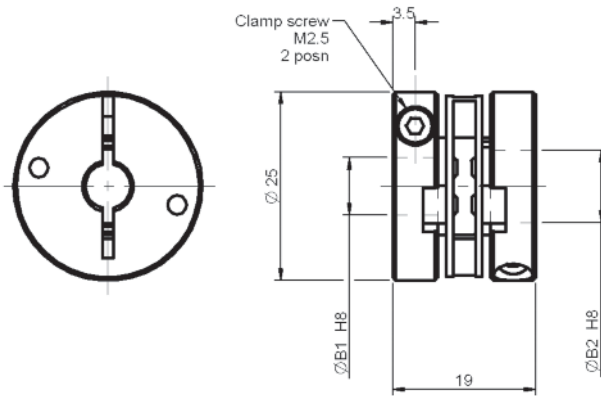

| H8        |           |
|-----------|-----------|
| Bore Size | Tolerance |
| 6         | +0.018    |
| 8         | +0.022    |
| 10        |           |

Couplings  
and Collars

### Part number selection table

| Part Number      | Hub Material            | Membrane Material | Bore ØB1 | Bore ØB2 |
|------------------|-------------------------|-------------------|----------|----------|
| RFSKK-2519-06-06 | Aluminium<br>(Anodised) | Polyamide         | 6        | 6        |
| RFSKK-2519-10-06 |                         | 6.6               | 10       | 6        |
| RFSKK-2519-08-08 |                         | re-inforced       | 8        | 8        |
| RFSKK-2519-10-10 |                         | fibreglass        | 10       | 10       |

### Technical specifications

| Size Ref | Max Speed<br>min <sup>-1</sup> | Max Torque<br>Ncm | Misalignment |             |                | Torsional Stiffness<br>Nm/rad | Radial Stiffness<br>N/mm | Moment of Inertia<br>gcm <sup>2</sup> | Max Screw Torque<br>Ncm | Approx Weight<br>g |
|----------|--------------------------------|-------------------|--------------|-------------|----------------|-------------------------------|--------------------------|---------------------------------------|-------------------------|--------------------|
|          |                                |                   | Radial<br>mm | Axial<br>mm | Angular<br>deg |                               |                          |                                       |                         |                    |
| 2519     | 12,000                         | 40                | $\pm 0.25$   | $\pm 0.4$   | $\pm 2.5$      | 22                            | 60                       | 13.5                                  | 65                      | 16                 |

### ? Technical support

- Zero backlash
- Maintenance free
- Recommended temperature range -10°C to +80°C
- Electrical isolation
- Technical information - see page T8-1
- Product overview - see pages 8-2 to 8-7





# Membrane Couplings Clamp Hub

6 - 12 mm Bore



**Associated Products**  
 Shafts: page 11-2  
 Bearings: page 12-1  
 Leadscrews: page 7-1  
 Intelligent motors: page 2-2

All dimensions in mm  
 General tolerances  $\pm 0.13$  mm

| H8        |           |
|-----------|-----------|
| Bore Size | Tolerance |
| 6         | +0.018    |
| 8         | +0.022    |
| 10        |           |
| 12        | +0.027    |

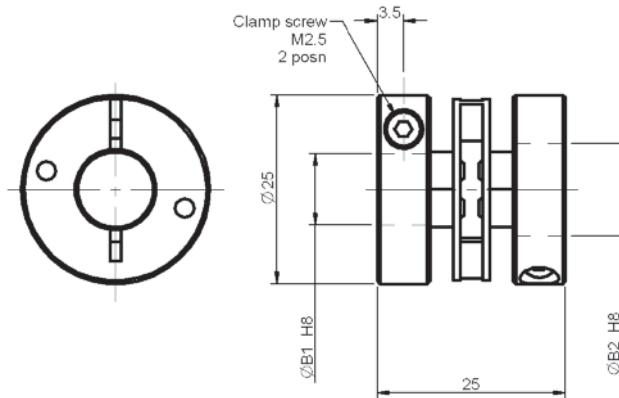

## Part number selection table

| Part Number      | Hub Material            | Membrane Material                             | Bore ØB1 | Bore ØB2 |
|------------------|-------------------------|---|----------|----------|
| RFSKK-2525-06-06 | Aluminium<br>(Anodised) | Polyamide<br>6.6<br>re-inforced<br>fibreglass | 6        | 6        |
| RFSKK-2525-10-06 |                         |   | 10       | 6        |
| RFSKK-2525-08-08 |                         |   | 8        | 8        |
| RFSKK-2525-10-10 |                         |   | 10       | 10       |
| RFSKK-2525-12-10 |                         |   | 12       | 10       |
| RFSKK-2525-12-12 |                         |   | 12       | 12       |

## Technical specifications

| Size Ref | Max Speed<br>$\text{min}^{-1}$ | Max Torque<br>Ncm | Misalignment |             |                | Torsional Stiffness<br>Nm/rad | Radial Stiffness<br>N/mm | Moment of Inertia<br>$\text{gcm}^2$ | Max Screw Torque<br>Ncm | Approx Weight<br>g |
|----------|--------------------------------|-------------------|--------------|-------------|----------------|-------------------------------|--------------------------|-------------------------------------|-------------------------|--------------------|
|          |                                |                   | Radial<br>mm | Axial<br>mm | Angular<br>deg |                               |                          |                                     |                         |                    |
| 2525     | 12,000                         | 40                | $\pm 0.25$   | $\pm 0.4$   | $\pm 2.5$      | 22                            | 60                       | 15                                  | 65                      | 18                 |

## Technical support

- Zero backlash
- Maintenance free
- Recommended temperature range  $-10^{\circ}\text{C}$  to  $+80^{\circ}\text{C}$
- Electrical isolation
- Technical information - see page T8-1
- Product overview - see pages 8-2 to 8-7



Contact us for product information, design support and custom solutions  
 sales@reliance.co.uk +44 (0) 1484 601002 www.reliance.co.uk



# 6 - 14 mm Bore

# Membrane Couplings Clamp Hub

All dimensions in mm  
General tolerances  $\pm 0.13$  mm

**Associated Products**  
Shafts: page 11-2  
Bearings: page 12-1  
Leadscrews: page 7-1  
Intelligent motors: page 2-2

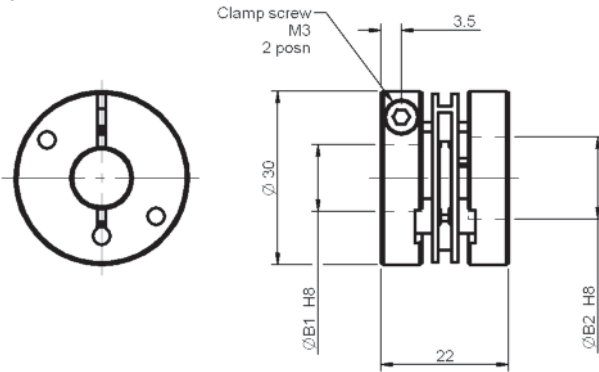

| H8        |           |
|-----------|-----------|
| Bore Size | Tolerance |
| 6         | +0.018    |
| 8         | +0.022    |
| 10        |           |
| 12        | +0.027    |
| 14        |           |

Couplings  
and Collars

## Part number selection table

| Part Number      | Hub Material            | Membrane Material                            | Bore ØB1 | Bore ØB2 |
|------------------|-------------------------|--|----------|----------|
| RFSKK-3022-06-06 | Aluminium<br>(Anodised) | Polyamide<br>6.6<br>reinforced<br>fibreglass | 6        | 6        |
| RFSKK-3022-10-06 |                         |  | 10       | 6        |
| RFSKK-3022-08-08 |                         |  | 8        | 8        |
| RFSKK-3022-10-10 |                         |  | 10       | 10       |
| RFSKK-3022-12-10 |                         |  | 12       | 10       |
| RFSKK-3022-12-12 |                         |  | 12       | 12       |
| RFSKK-3022-14-14 |                         |  | 14       | 14       |

## Technical specifications

| Size Ref | Max Speed<br>$\text{min}^{-1}$ | Max Torque<br>Ncm | Misalignment |             |                | Torsional Stiffness<br>Nm/rad | Radial Stiffness<br>N/mm | Moment of Inertia<br>$\text{gcm}^2$ | Max Screw Torque<br>Ncm | Approx Weight<br>g |
|----------|--------------------------------|-------------------|--------------|-------------|----------------|-------------------------------|--------------------------|-------------------------------------|-------------------------|--------------------|
|          |                                |                   | Radial<br>mm | Axial<br>mm | Angular<br>deg |                               |                          |                                     |                         |                    |
| 3022     | 12,000                         | 60                | $\pm 0.3$    | $\pm 0.4$   | $\pm 2.5$      | 30                            | 40                       | 35                                  | 80                      | 30                 |

## ? Technical support

- Zero backlash
- High torsional stiffness and low bearing loads
- Maintenance free
- Recommended temperature range  $-10^{\circ}\text{C}$  to  $+80^{\circ}\text{C}$
- Electrical isolation
- High rigidity
- Technical information - see page T8-1
- Product overview - see pages 8-2 to 8-7



# Membrane Couplings Clamp Hub

6 - 14 mm Bore



**Associated Products**  
 Shafts: page 11-2  
 Bearings: page 12-1  
 Leadscrews: page 7-1  
 Intelligent motors: page 2-2

All dimensions in mm  
 General tolerances  $\pm 0.13$  mm

| H8        |           |
|-----------|-----------|
| Bore Size | Tolerance |
| 6         | +0.018    |
| 8         | +0.022    |
| 10        |           |
| 12        | +0.027    |
| 14        |           |

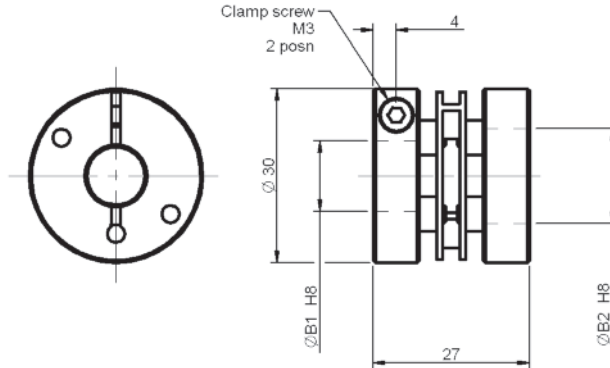

Couplings  
and Collars

## Part number selection table

| Part Number      | Hub Material            | Membrane Material                            | Bore ØB1 | Bore ØB2 |
|------------------|-------------------------|--|----------|----------|
| RFSKK-3027-06-06 | Aluminium<br>(Anodised) | Polyamide<br>6.6<br>reinforced<br>fibreglass | 6        | 6        |
| RFSKK-3027-10-06 |                         |  | 10       | 6        |
| RFSKK-3027-08-08 |                         |  | 8        | 8        |
| RFSKK-3027-10-10 |                         |  | 10       | 10       |
| RFSKK-3027-12-10 |                         |  | 12       | 10       |
| RFSKK-3027-12-12 |                         |  | 12       | 12       |
| RFSKK-3027-14-12 |                         |  | 14       | 12       |
| RFSKK-3027-14-14 |                         |  | 14       | 14       |

## Technical specifications

| Size Ref | Max Speed<br>$\text{min}^{-1}$ | Max Torque<br>Ncm | Misalignment |             |                | Torsional Stiffness<br>Nm/rad | Radial Stiffness<br>N/mm | Moment of Inertia<br>$\text{gcm}^2$ | Max Screw Torque<br>Ncm | Approx Weight<br>g |
|----------|--------------------------------|-------------------|--------------|-------------|----------------|-------------------------------|--------------------------|-------------------------------------|-------------------------|--------------------|
|          |                                |                   | Radial<br>mm | Axial<br>mm | Angular<br>deg |                               |                          |                                     |                         |                    |
| 3027     | 12,000                         | 60                | $\pm 0.3$    | $\pm 0.4$   | $\pm 2.5$      | 30                            | 40                       | 37                                  | 80                      | 32                 |

## ? Technical support

- Zero backlash
- High torsional stiffness and low bearing loads
- Maintenance free
- Recommended temperature range  $-10^{\circ}\text{C}$  to  $+80^{\circ}\text{C}$
- Electrical isolation
- High rigidity
- Technical information - see page T8-1
- Product overview - see pages 8-2 to 8-7



Contact us for product information, design support and custom solutions  
[sales@reliance.co.uk](mailto:sales@reliance.co.uk)    +44 (0) 1484 601002    [www.reliance.co.uk](http://www.reliance.co.uk)



# 6 - 12 mm Bore

# Curved Jaw Couplings Set Screw Hub

All dimensions in mm  
General tolerances  $\pm 0.13$  mm

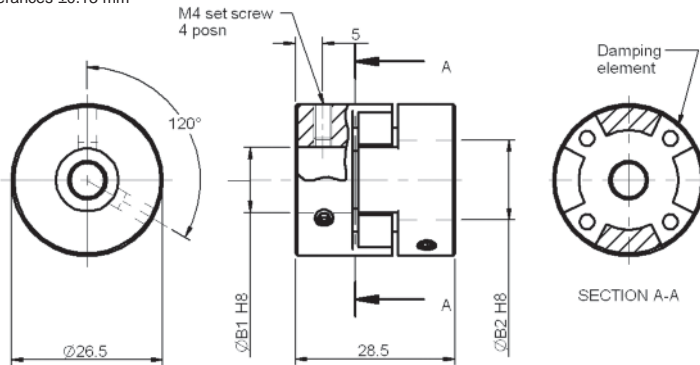

**Associated Products**  
Shafts: page 11-2  
Bearings: page 12-1  
Leadscrews: page 7-1  
Intelligent motors: page 2-2

| H8        |           |
|-----------|-----------|
| Bore Size | Tolerance |
| 6         | +0.018    |
| 8         | +0.022    |
| 10        |           |
| 12        | +0.027    |

## Part number selection table

Example Part No:- RKKAS - 1500 - 08 - 06 - 92

| Basic Part Number | Hub Material         | Damping Element Material | Element Hardness                       | Bore ØB1 | Bore ØB2 |
|-------------------|----------------------|--------------------------|--|----------|----------|
| RKKAS-1500-06-06  | Aluminium (Anodised) | Polyurethane             | -80 (blue)<br>-92 (white)<br>-98 (red) | 6        | 6        |
| RKKAS-1500-08-06  |                      |                          |  | 8        | 6        |
| RKKAS-1500-08-08  |                      |                          |  | 8        | 8        |
| RKKAS-1500-10-08  |                      |                          |  | 10       | 8        |
| RKKAS-1500-10-10  |                      |                          |  | 10       | 10       |
| RKKAS-1500-12-10  |                      |                          |  | 12       | 10       |

## Technical specifications

| Element Hardness | Max Speed<br>min <sup>-1</sup> | Max Torque<br>Ncm | Misalignment at 750rpm |             |                | Twist at Max Torque<br>Deg | Moment of Inertia<br>gcm <sup>2</sup> | Max Screw Torque<br>Ncm | Approx Weight<br>g |
|------------------|--------------------------------|-------------------|------------------------|-------------|----------------|----------------------------|---------------------------------------|-------------------------|--------------------|
|                  |                                |                   | Radial<br>mm           | Axial<br>mm | Angular<br>deg |                            |                                       |                         |                    |
| 80               | 19,000                         | 800               | $\pm 0.22$             | $\pm 1.0$   | $\pm 1.3$      | 10                         | 30                                    | 120                     | 34                 |
| 92               |                                | 1500              | $\pm 0.22$             | $\pm 1.0$   | $\pm 1.3$      | 10                         | 30                                    | 120                     | 34                 |
| 98               |                                | 2500              | $\pm 0.22$             | $\pm 1.0$   | $\pm 1.3$      | 10                         | 30                                    | 120                     | 34                 |

## Technical support

- Zero backlash
- Alternative damping element hardness
- Maintenance free
- Recommended temperature range -30°C to +80°C
- Torque ripple reduction
- Technical information - see page T8-1
- Product overview - see pages 8-2 to 8-7



# Curved Jaw Couplings Clamp Hub

6 - 12 mm Bore



**Associated Products**  
 Shafts: page 11-2  
 Bearings: page 12-1  
 Leadscrews: page 7-1  
 Intelligent motors: page 2-2

All dimensions in mm  
 General tolerances  $\pm 0.13$  mm

| H8        |           |
|-----------|-----------|
| Bore Size | Tolerance |
| 6         | +0.018    |
| 8         | +0.022    |
| 10        |           |
| 12        | +0.027    |

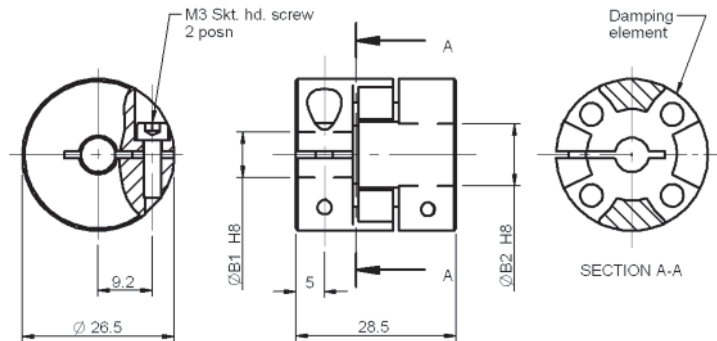

## Part number selection table

| Example Part No:- <b>RKKAK - 1500 - 08 - 06 - 92</b> |                      |                          |  |          |          |
|--|----------------------|--------------------------|--|----------|----------|
| Basic Part Number                                    | Hub Material         | Damping Element Material | Element Hardness                       | Bore ØB1 | Bore ØB2 |
| RKKAK-1500-06-06                                     | Aluminium (Anodised) | Polyurethane             | -80 (blue)<br>-92 (white)<br>-98 (red) | 6        | 6        |
| RKKAK-1500-08-06                                     |                      |                          |  | 8        | 6        |
| RKKAK-1500-08-08                                     |                      |                          |  | 8        | 8        |
| RKKAK-1500-10-08                                     |                      |                          |  | 10       | 8        |
| RKKAK-1500-10-10                                     |                      |                          |  | 10       | 10       |
| RKKAK-1500-12-10                                     |                      |                          |  | 12       | 10       |

## Technical specifications

| Element Hardness | Max Speed<br>min <sup>-1</sup> | Max Torque<br>Ncm | Misalignment at 750rpm |             |                | Twist at Max Torque<br>Deg | Moment of Inertia<br>gcm <sup>2</sup> | Max Screw Torque<br>Ncm | Approx Weight<br>g |
|------------------|--------------------------------|-------------------|------------------------|-------------|----------------|----------------------------|---------------------------------------|-------------------------|--------------------|
|                  |                                |                   | Radial<br>mm           | Axial<br>mm | Angular<br>deg |                            |                                       |                         |                    |
| 80               | 19,000                         | 800               | $\pm 0.22$             | $\pm 1.0$   | $\pm 1.3$      | 10                         | 30                                    | 150                     | 34                 |
| 92               |                                | 1500              | $\pm 0.22$             | $\pm 1.0$   | $\pm 1.3$      | 10                         | 30                                    | 150                     | 34                 |
| 98               |                                | 2500              | $\pm 0.22$             | $\pm 1.0$   | $\pm 1.3$      | 10                         | 30                                    | 150                     | 34                 |

## ? Technical support

- Zero backlash
- Alternative damping element hardness
- Maintenance free
- Recommended temperature range -30°C to +80°C
- Torque ripple reduction
- Technical information - see page T8-1
- Product overview - see pages 8-2 to 8-7



Contact us for product information, design support and custom solutions  
 sales@reliance.co.uk +44 (0) 1484 601002 www.reliance.co.uk



# 1 - 5 mm Bore

# Micro Spiral Beam Couplings Set Screw Hub

All dimensions in mm  
General tolerances  $\pm 0.13$  mm

**Associated Products**  
Shafts: page 11-2  
Bearings: page 12-1  
Leadscrews: page 7-1  
Intelligent motors: page 2-2

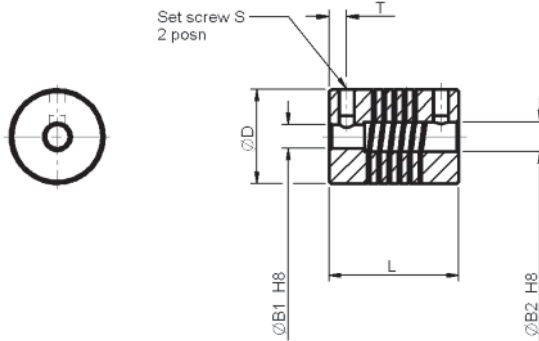

| H8        |           |
|-----------|-----------|
| Bore Size | Tolerance |
| 1         | +0.014    |
| 2         |           |
| 3         |           |
| 4         | +0.018    |
| 5         |           |

Couplings  
and Collars

## Part number selection table

| Part Number      | Material  | Bore | Bore | O/D | Length<br>L | Screw<br>Position<br>T | Screw<br>Thread<br>S |
|------------------|-----------|------|------|-----|-------------|------------------------|----------------------|
|                  |           | ØB1  | ØB2  | ØD  |             |                        |                      |
| RWKAS-6508-01-01 | Aluminium | 1    | 1    | 6.5 | 8           | 1.3                    | M1.6                 |
| RWKAS-6508-02-01 |           | 2    | 1    |     |             |                        |                      |
| RWKAS-6508-02-02 |           | 2    | 2    |     |             |                        |                      |
| RWKAS-1015-02-02 | Aluminium | 2    | 2    | 10  | 15          | 2.0                    | M2                   |
| RWKAS-1015-03-02 |           | 3    | 2    |     |             |                        |                      |
| RWKAS-1015-04-02 |           | 4    | 2    |     |             |                        |                      |
| RWKAS-1015-05-02 |           | 5    | 2    |     |             |                        |                      |
| RWKAS-1015-03-03 |           | 3    | 3    |     |             |                        |                      |
| RWKAS-1015-05-03 |           | 5    | 3    |     |             |                        |                      |

## Technical specifications

| Size | Max<br>Speed<br>min <sup>-1</sup> | Max<br>Torque<br>Ncm | Misalignment |             |                | Torsional<br>Stiffness<br>Nm/rad | Radial<br>Stiffness<br>N/mm | Moment<br>of<br>Inertia<br>gcm <sup>2</sup> | Max<br>Screw<br>Torque<br>Ncm | Approx<br>Weight<br>g |
|------|-----------------------------------|----------------------|--------------|-------------|----------------|----------------------------------|-----------------------------|---|-------------------------------|-----------------------|
|      |                                   |                      | Radial<br>mm | Axial<br>mm | Angular<br>deg |                                  |                             |   |                               |                       |
| 6508 | 8,000                             | 2                    | ±0.10        | ±0.15       | ±2.0           | 0.55                             | 24                          | 0.02  | 8                             | 0.5                   |
| 1015 |                                   | 15                   | ±0.15        | ±0.20       | ±2.0           | 2.20                             | 22                          | 0.34  | 15                            | 2.4                   |

## ? Technical support

- Zero backlash
- High torsional stiffness and low bearing loads
- Maintenance free
- Recommended temperature range -30°C to +150°C
- One piece construction
- Technical information - see page T8-1
- Product overview - see pages 8-2 to 8-7



# Spiral Beam Couplings Set Screw Hub

2 - 6 mm Bore



**Associated Products**  
 Shafts: page 11-2  
 Bearings: page 12-1  
 Leadscrews: page 7-1  
 Intelligent motors: page 2-2

All dimensions in mm  
 General tolerances  $\pm 0.13$  mm

| H8        |           |
|-----------|-----------|
| Bore Size | Tolerance |
| 2         | +0.014    |
| 3         |           |
| 4         | +0.018    |
| 5         |           |
| 6         |           |

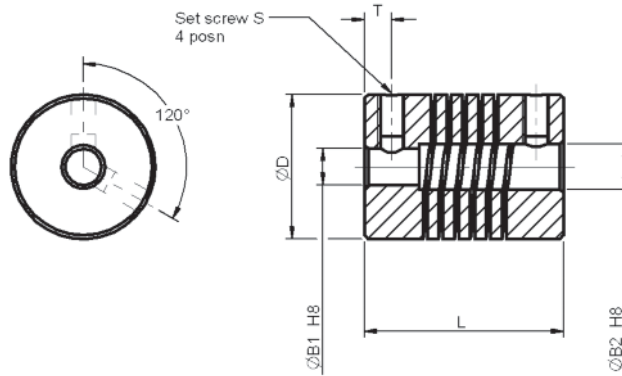

## Part number selection table

| Part Number      | Material  | Bore | Bore | O/D | Length<br>L | Screw<br>Position<br>T | Screw<br>Thread<br>S |
|------------------|-----------|------|------|-----|-------------|------------------------|----------------------|
|                  |           | ØB1  | ØB2  | ØD  |             |                        |                      |
| RWKAS-1218-04-02 | Aluminium | 4    | 2    | 12  | 18          | 2.5                    | M2.5                 |
| RWKAS-1218-03-03 |           | 3    | 3    |     |             |                        |                      |
| RWKAS-1218-04-03 |           | 4    | 3    |     |             |                        |                      |
| RWKAS-1218-04-04 |           | 4    | 4    |     |             |                        |                      |
| RWKAS-1622-03-03 | Aluminium | 3    | 3    | 16  | 22          | 3.0                    | M3                   |
| RWKAS-1622-05-03 |           | 5    | 3    |     |             |                        |                      |
| RWKAS-1622-04-04 |           | 4    | 4    |     |             |                        |                      |
| RWKAS-1622-05-04 |           | 5    | 4    |     |             |                        |                      |
| RWKAS-1622-05-05 |           | 5    | 5    |     |             |                        |                      |
| RWKAS-1622-06-06 |           | 6    | 6    |     |             |                        |                      |

## Technical specifications

| Size | Max<br>Speed<br>min <sup>-1</sup> | Max<br>Torque<br>Ncm | Misalignment |             |                | Torsional<br>Stiffness<br>Nm/rad | Radial<br>Stiffness<br>N/mm | Moment<br>of<br>Inertia<br>gcm <sup>2</sup> | Max<br>Screw<br>Torque<br>Ncm | Approx<br>Weight<br>g |
|------|-----------------------------------|----------------------|--------------|-------------|----------------|----------------------------------|-----------------------------|---|-------------------------------|-----------------------|
|      |                                   |                      | Radial<br>mm | Axial<br>mm | Angular<br>deg |                                  |                             |   |                               |                       |
| 1218 | 8,000                             | 25                   | $\pm 0.15$   | $\pm 0.25$  | $\pm 2.5$      | 2.8                              | 28                          | 0.83  | 35                            | 4.0                   |
| 1622 |                                   | 40                   | $\pm 0.20$   | $\pm 0.30$  | $\pm 3.0$      | 5.0                              | 34                          | 3.20  | 50                            | 9.5                   |

### Technical support

- Zero backlash
- High torsional stiffness and low bearing loads
- Maintenance free
- Recommended temperature range -30°C to +150°C
- One piece construction
- Technical information - see page T8-1
- Product overview - see pages 8-2 to 8-7



Contact us for product information, design support and custom solutions  
 sales@reliance.co.uk +44 (0) 1484 601002 www.reliance.co.uk



# 4 - 14 mm Bore

# Spiral Beam Couplings Set Screw Hub

All dimensions in mm  
General tolerances  $\pm 0.13$  mm

**Associated Products**  
Shafts: page 11-2  
Bearings: page 12-1  
Leadscrews: page 7-1  
Intelligent motors: page 2-2

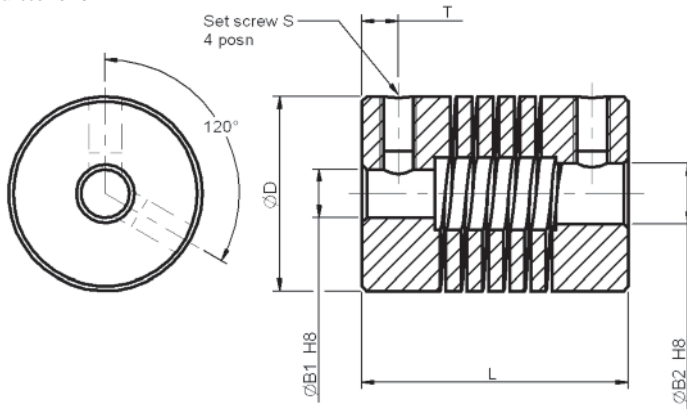

| H8        |           |
|-----------|-----------|
| Bore Size | Tolerance |
| 4         |           |
| 5         | +0.018    |
| 6         |           |
| 8         |           |
| 10        | +0.022    |
| 12        |           |
| 14        | +0.027    |

**Part number selection table**

| Part Number      | Material                | Bore | Bore | O/D | Length<br>L | Screw<br>Position | Screw<br>Thread |
|------------------|-------------------------|------|------|-----|-------------|-------------------|-----------------|
|                  |                         | ØB1  | ØB2  | ØD  |             | T                 | S               |
| RWKAS-1922-04-04 | Aluminium               | 4    | 4    | 19  | 22          | 3.0               | M3              |
| RWKAS-1922-06-04 |                         | 6    | 4    |     |             |                   |                 |
| RWKAS-1922-05-05 |                         | 5    | 5    |     |             |                   |                 |
| RWKAS-1922-06-06 |                         | 6    | 6    |     |             |                   |                 |
| RWKAS-1922-08-06 |                         | 8    | 6    |     |             |                   |                 |
| RWKAS-1922-08-08 | 8                       | 8    |      |     |             |                   |                 |
| RWKAS-2019-06-04 | Aluminium               | 6    | 4    | 20  | 19          | 2.8               | M3              |
| RWKAS-2019-05-05 |                         | 5    | 5    |     |             |                   |                 |
| RWKAS-2019-06-06 |                         | 6    | 6    |     |             |                   |                 |
| RWKAS-2019-08-06 |                         | 8    | 6    |     |             |                   |                 |
| RWKAS-2524-06-06 | Aluminium<br>(Anodised) | 6    | 6    | 25  | 24          | 3                 | M4              |
| RWKAS-2524-08-06 |                         | 8    | 6    |     |             |                   |                 |
| RWKAS-2524-10-06 |                         | 10   | 6    |     |             |                   |                 |
| RWKAS-2524-08-08 |                         | 8    | 8    |     |             |                   |                 |
| RWKAS-2524-10-08 |                         | 10   | 8    |     |             |                   |                 |
| RWKAS-2524-10-10 |                         | 10   | 10   |     |             |                   |                 |
| RWKAS-2524-12-12 |                         | 12   | 12   |     |             |                   |                 |
| RWKAS-2532-06-06 | Aluminium<br>(Anodised) | 6    | 6    | 25  | 32          | 4                 | M4              |
| RWKAS-2532-08-06 |                         | 8    | 6    |     |             |                   |                 |
| RWKAS-2532-10-06 |                         | 10   | 6    |     |             |                   |                 |
| RWKAS-2532-08-08 |                         | 8    | 8    |     |             |                   |                 |
| RWKAS-2532-10-08 |                         | 10   | 8    |     |             |                   |                 |
| RWKAS-2532-10-10 |                         | 10   | 10   |     |             |                   |                 |
| RWKAS-2532-12-10 |                         | 12   | 10   |     |             |                   |                 |
| RWKAS-2532-12-12 |                         | 12   | 12   |     |             |                   |                 |



# Spiral Beam Couplings Set Screw Hub

4 - 14 mm Bore



## Part number selection table continued

| Part Number      | Material                | Bore | Bore | O/D | Length | Screw Position | Screw Thread |
|------------------|-------------------------|------|------|-----|--------|----------------|--------------|
|                  |                         | ØB1  | ØB2  | ØD  | L      | T              | S            |
| RWKAS-3030-10-10 | Aluminium<br>(Anodised) | 10   | 10   | 30  | 30     | 4              | M4           |
| RWKAS-3030-12-10 |                         | 12   | 10   |     |        |                |              |
| RWKAS-3030-14-10 |                         | 14   | 10   |     |        |                |              |
| RWKAS-3038-10-10 | Aluminium<br>(Anodised) | 10   | 10   | 30  | 38     | 5              | M4           |
| RWKAS-3038-12-10 |                         | 12   | 10   |     |        |                |              |
| RWKAS-3038-14-10 |                         | 14   | 10   |     |        |                |              |
| RWKAS-3038-12-12 |                         | 12   | 12   |     |        |                |              |

## Technical specifications

| Size Ref | Max Speed<br>min <sup>-1</sup> | Max Torque<br>Ncm | Misalignment |             |                | Torsional Stiffness<br>Nm/rad | Radial Stiffness<br>N/mm | Moment of Inertia<br>gcm <sup>2</sup> | Max Screw Torque<br>Ncm | Approx Weight<br>g |
|----------|--------------------------------|-------------------|--------------|-------------|----------------|-------------------------------|--------------------------|---------------------------------------|-------------------------|--------------------|
|          |                                |                   | Radial<br>mm | Axial<br>mm | Angular<br>deg |                               |                          |                                       |                         |                    |
| 1922     | 8,000                          | 60                | ±0.25        | ±0.4        | ±3.5           | 9                             | 40                       | 6.7                                   | 50                      | 13                 |
| 2019     |                                | 60                | ±0.25        | ±0.4        | ±3.5           | 9                             | 40                       | 6.0                                   | 50                      | 12                 |
| 2524     |                                | 100               | ±0.30        | ±0.5        | ±4.0           | 20                            | 60                       | 22.2                                  | 120                     | 26                 |
| 2532     |                                | 100               | ±0.30        | ±0.5        | ±4.0           | 18                            | 50                       | 30.0                                  | 120                     | 35                 |
| 3030     |                                | 150               | ±0.30        | ±0.5        | ±4.0           | 21                            | 60                       | 57.0                                  | 120                     | 45                 |
| 3038     |                                | 150               | ±0.30        | ±0.5        | ±4.0           | 21                            | 60                       | 76.0                                  | 120                     | 60                 |

Couplings and Collars

### ? Technical support

- Zero backlash
- High torsional stiffness and low bearing loads
- Maintenance free
- Recommended temperature range -30°C to +150°C
- One piece construction
- Technical information - see page T8-1
- Product overview - see pages 8-2 to 8-7





## 2 - 14 mm Bore

# Spiral Beam Couplings Clamp Hub

All dimensions in mm  
General tolerances  $\pm 0.13$  mm

**Associated Products**  
Shafts: page 11-2  
Bearings: page 12-1  
Leadscrews: page 7-1  
Intelligent motors: page 2-2

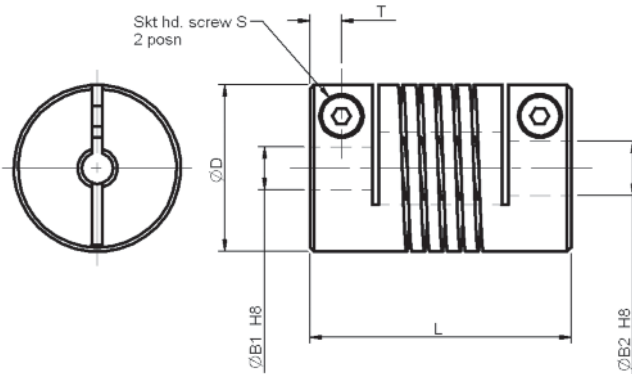

| H8        |           |
|-----------|-----------|
| Bore Size | Tolerance |
| 2         | +0.014    |
| 3         |           |
| 4         | +0.018    |
| 5         |           |
| 6         |           |
| 8         | +0.022    |
| 10        |           |
| 12        | +0.027    |
| 14        |           |

Couplings  
and Collars

### Part number selection table

| Part Number      | Material                | Bore | Bore | O/D | Length<br>L | Screw<br>Position<br>T | Screw<br>Thread<br>S |
|------------------|-------------------------|------|------|-----|-------------|------------------------|----------------------|
|                  |                         | ØB1  | ØB2  | ØD  |             |                        |                      |
| RWKAK-1421-02-02 | Aluminium<br>(Anodised) | 2    | 2    | 14  | 21          | 2.6                    | M2                   |
| RWKAK-1421-03-02 |                         | 3    | 2    |     |             |                        |                      |
| RWKAK-1421-03-03 |                         | 3    | 3    |     |             |                        |                      |
| RWKAK-1421-04-03 |                         | 4    | 3    |     |             |                        |                      |
| RWKAK-1421-04-04 |                         | 4    | 4    |     |             |                        |                      |
| RWKAK-1625-03-03 | Aluminium<br>(Anodised) | 3    | 3    | 16  | 25          | 3.0                    | M2                   |
| RWKAK-1625-05-03 |                         | 5    | 3    |     |             |                        |                      |
| RWKAK-1625-04-04 |                         | 4    | 4    |     |             |                        |                      |
| RWKAK-1625-06-04 |                         | 6    | 4    |     |             |                        |                      |
| RWKAK-1625-05-05 |                         | 5    | 5    |     |             |                        |                      |
| RWKAK-1625-06-05 |                         | 6    | 5    |     |             |                        |                      |
| RWKAK-1928-04-04 | Aluminium<br>(Anodised) | 4    | 4    | 19  | 28          | 3.3                    | M3                   |
| RWKAK-1928-06-04 |                         | 6    | 4    |     |             |                        |                      |
| RWKAK-1928-05-05 |                         | 5    | 5    |     |             |                        |                      |
| RWKAK-1928-06-05 |                         | 6    | 5    |     |             |                        |                      |
| RWKAK-1928-06-06 |                         | 6    | 6    |     |             |                        |                      |
| RWKAK-2532-06-06 | Aluminium<br>(Anodised) | 6    | 6    | 25  | 32          | 4.0                    | M3                   |
| RWKAK-2532-08-06 |                         | 8    | 6    |     |             |                        |                      |
| RWKAK-2532-10-06 |                         | 10   | 6    |     |             |                        |                      |
| RWKAK-2532-08-08 |                         | 8    | 8    |     |             |                        |                      |
| RWKAK-2532-10-08 |                         | 10   | 8    |     |             |                        |                      |
| RWKAK-2532-10-10 |                         | 10   | 10   |     |             |                        |                      |
| RWKAK-2532-10-10 |                         | 10   | 10   |     |             |                        |                      |
| RWKAK-2532-12-10 |                         | 12   | 10   |     |             |                        |                      |

# Spiral Beam Couplings Clamp Hub

2 - 14 mm Bore



## Part number selection table continued

| Part Number      | Material                | Bore | Bore | O/D | Length | Screw Position | Screw Thread |
|------------------|-------------------------|------|------|-----|--------|----------------|--------------|
|                  |                         | ØB1  | ØB2  | ØD  | L      | T              | S            |
| RWKAK-3038-10-10 | Aluminium<br>(Anodised) | 10   | 10   | 30  | 38     | 4.8            | M4           |
| RWKAK-3038-12-10 |                         | 12   | 10   |     |        |                |              |
| RWKAK-3038-12-12 |                         | 12   | 12   |     |        |                |              |
| RWKAK-3038-14-14 |                         | 14   | 14   |     |        |                |              |

## Technical specifications

| Size Ref | Max Speed<br>min <sup>-1</sup> | Max Torque<br>Ncm | Misalignment |             |                | Torsional Stiffness<br>Nm/rad | Radial Stiffness<br>N/mm | Moment of Inertia<br>gcm <sup>2</sup> | Max Screw Torque<br>Ncm | Approx Weight<br>g |
|----------|--------------------------------|-------------------|--------------|-------------|----------------|-------------------------------|--------------------------|---------------------------------------|-------------------------|--------------------|
|          |                                |                   | Radial<br>mm | Axial<br>mm | Angular<br>deg |                               |                          |                                       |                         |                    |
| 1421     | 6,000                          | 50                | ±0.20        | ±0.25       | ±3.0           | 4.5                           | 22                       | 1.9                                   | 50                      | 6.5                |
| 1625     |                                | 60                | ±0.20        | ±0.30       | ±3.5           | 5.5                           | 30                       | 3.8                                   | 50                      | 10                 |
| 1928     |                                | 80                | ±0.25        | ±0.40       | ±4.0           | 8                             | 36                       | 8.7                                   | 80                      | 16                 |
| 2532     |                                | 100               | ±0.35        | ±0.50       | ±4.0           | 16                            | 45                       | 29.0                                  | 100                     | 34                 |
| 3038     |                                | 150               | ±0.35        | ±0.50       | ±4.0           | 19                            | 60                       | 76.0                                  | 100                     | 58                 |

Couplings  
and Collars

### ? Technical support

- Zero backlash
- High torsional stiffness and low bearing loads
- Maintenance free
- Recommended temperature range -30°C to +150°C
- One piece construction
- Technical information - see page T8-1
- Product overview - see pages 8-2 to 8-7





# 8 - 10 mm Bore Stainless Steel

# Spiral Beam Couplings Set Screw Hub

All dimensions in mm  
General tolerances  $\pm 0.13$  mm

**Associated Products**  
Shafts: page 11-2  
Bearings: page 12-1  
Leadscrews: page 7-1  
Intelligent motors: page 2-2

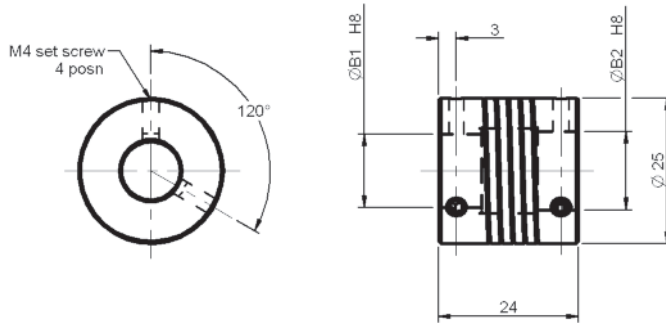

| H8        |           |
|-----------|-----------|
| Bore Size | Tolerance |
| 8         | +0.022    |
| 10        |           |

Couplings  
and Collars

## Part number selection table

| Part Number             | Material  | Bore ØB1 | Bore ØB2 |
|-------------------------|-----------|----------|----------|
| <b>RWKXS-2524-08-08</b> | Stainless | 8        | 8        |
| <b>RWKXS-2524-10-10</b> | steel     | 10       | 10       |

## Technical specifications

| Size Ref | Max Speed<br>$\text{min}^{-1}$ | Max Torque<br>Ncm | Misalignment |             |                | Torsional Stiffness<br>Nm/rad | Radial Stiffness<br>N/mm | Moment of Inertia<br>$\text{gcm}^2$ | Max Screw Torque<br>Ncm | Approx Weight<br>g |
|----------|--------------------------------|-------------------|--------------|-------------|----------------|-------------------------------|--------------------------|-------------------------------------|-------------------------|--------------------|
|          |                                |                   | Radial<br>mm | Axial<br>mm | Angular<br>deg |                               |                          |                                     |                         |                    |
| 2524     | 8,000                          | 200               | $\pm 0.3$    | $\pm 0.5$   | $\pm 4.0$      | 40                            | 250                      | 64                                  | 200                     | 65                 |

## ? Technical support

- Zero backlash
- High torsional stiffness
- Maintenance free
- Recommended temperature range  $-30^{\circ}\text{C}$  to  $+180^{\circ}\text{C}$
- One piece construction
- Technical information - see [page T8-1](#)
- Product overview - see [pages 8-2 to 8-7](#)



# Spiral Beam Couplings Clamp Hub

6 - 10 mm Bore  
Stainless Steel



**Associated Products**  
 Shafts: page 11-2  
 Bearings: page 12-1  
 Leadscrews: page 7-1  
 Intelligent motors: page 2-2

All dimensions in mm  
 General tolerances  $\pm 0.13$  mm

| H8        |           |
|-----------|-----------|
| Bore Size | Tolerance |
| 6         | +0.018    |
| 8         | +0.022    |
| 10        | +0.022    |

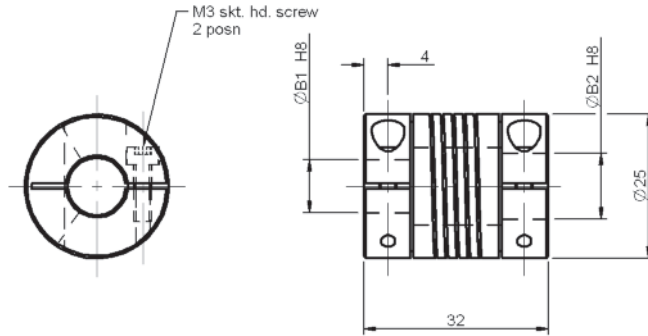

## Part number selection table

| Part Number             | Material        | Bore ØB1 | Bore ØB2 |
|-------------------------|-----------------|----------|----------|
| <b>RWKXK-2532-10-06</b> | Stainless steel | 10       | 6        |
| <b>RWKXK-2532-08-08</b> |                 | 8        | 8        |
| <b>RWKXK-2532-10-10</b> |                 | 10       | 10       |

## Technical specifications

| Size Ref | Max Speed<br>min <sup>-1</sup> | Max Torque<br>Ncm | Misalignment |             |                | Torsional Stiffness<br>Nm/rad | Radial Stiffness<br>N/mm | Moment of Inertia<br>gcm <sup>2</sup> | Max Screw Torque<br>Ncm | Approx Weight<br>g |
|----------|--------------------------------|-------------------|--------------|-------------|----------------|-------------------------------|--------------------------|---------------------------------------|-------------------------|--------------------|
|          |                                |                   | Radial<br>mm | Axial<br>mm | Angular<br>deg |                               |                          |                                       |                         |                    |
| 2532     | 6,000                          | 200               | $\pm 0.35$   | $\pm 0.5$   | $\pm 4.0$      | 29                            | 150                      | 84                                    | 200                     | 88                 |

## ? Technical support

- Zero backlash
- High torsional stiffness
- Maintenance free
- Recommended temperature range -30°C to +180°C
- One piece construction
- Technical information - see [page T8-1](#)
- Product overview - see [pages 8-2 to 8-7](#)

Contact us for product information, design support and custom solutions  
[sales@reliance.co.uk](mailto:sales@reliance.co.uk)    +44 (0) 1484 601002    [www.reliance.co.uk](http://www.reliance.co.uk)



# 6 - 10 mm Bore

# Radial Tooth Couplings

All dimensions in mm  
General tolerances  $\pm 0.13$  mm

**Associated Products**  
Shafts: page 11-2  
Bearings: page 12-1  
Leadscrews: page 7-1  
Intelligent motors: page 2-2

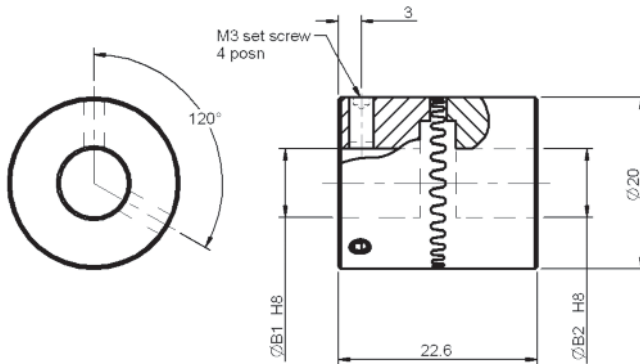

| H8        |           |
|-----------|-----------|
| Bore Size | Tolerance |
| 6         | +0.018    |
| 8         |           |
| 10        | +0.022    |

## Part number selection table

| Part Number      | Coupling Material               | Bore ØB1 | Bore ØB2 |
|------------------|---------------------------------|----------|----------|
| RSKSS-2022-06-06 | Steel                           | 6        | 6        |
| RSKSS-2022-08-06 |                                 | 8        | 6        |
| RSKSS-2022-10-06 | 9S Mn Pb 28<br>(Black finished) | 10       | 6        |
| RSKSS-2022-08-08 |                                 | 8        | 8        |
| RSKSS-2022-10-10 |                                 | 10       | 10       |

## Technical specifications

| Size Ref | Max Speed<br>min <sup>-1</sup> | Max Torque<br>Ncm | Misalignment |             |                | Module<br>mm | Radial Stiffness<br>N/mm | Moment of Inertia<br>gcm <sup>2</sup> | Max Screw Torque<br>Ncm | Approx Weight<br>g |
|----------|--------------------------------|-------------------|--------------|-------------|----------------|--------------|--------------------------|---------------------------------------|-------------------------|--------------------|
|          |                                |                   | Radial<br>mm | Axial<br>mm | Angular<br>deg |              |                          |                                       |                         |                    |
| 2022     | 8,000                          | 200               | N/A          | N/A         | $\pm 0.5$      | 0.7          | N/A                      | 26                                    | 80                      | 42                 |

## Technical support

- Recommended temperature range -30°C to +120°C
- Self centering connection
- Technical information - see page T8-1
- Product overview - see pages 8-2 to 8-7



# Friction Clutch - Spiral Spring Clamp Hub

4 - 6 mm Bore



**Associated Products**  
 Shafts: page 11-2  
 Bearings: page 12-1  
 Leadscrews: page 7-1  
 Intelligent motors: page 2-2

All dimensions in mm  
 General tolerances  $\pm 0.13$  mm

| H8        |           |
|-----------|-----------|
| Bore Size | Tolerance |
| 4         | +0.018    |
| 5         |           |
| 6         |           |

| f8        |           |
|-----------|-----------|
| Shaft Dia | Tolerance |
| 10        | -0.013    |
|           | -0.035    |

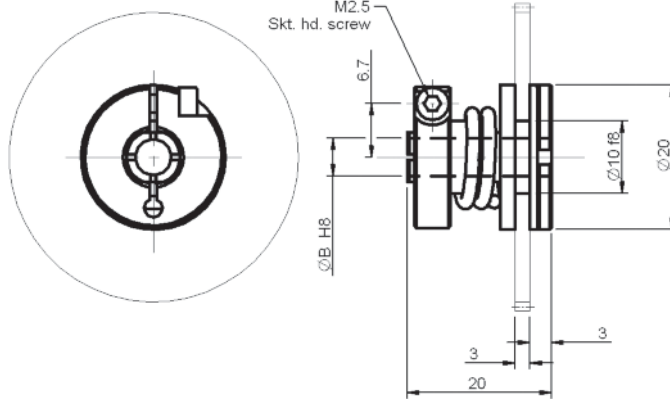

Couplings and Collars

## Technical specifications

| Part Number   | Bore<br>ØB | Max Speed<br>min <sup>-1</sup> | Max Adjustable Torque<br>Ncm | Moment of Inertia<br>gcm <sup>2</sup> | Max Screw Torque<br>Ncm | Material         |               | Approx Weight<br>g |
|---------------|------------|--------------------------------|------------------------------|---------------------------------------|-------------------------|------------------|---------------|--------------------|
|               |            |                                |                              |                                       |                         | Flange           | Clutch Lining |                    |
| RRKSK-2020-04 | 4          | 50                             | 30                           | 8.4                                   | 100                     | Steel            | Nylatron      | 20                 |
| RRKSK-2020-05 | 5          |                                |                              |                                       |                         | 9S Mn Pb 28      |               |                    |
| RRKSK-2020-06 | 6          |                                |                              |                                       |                         | (Black finished) |               |                    |

Note: Gear not included, manufactured on request, please enquire

## ? Technical support

- Zero backlash before slipping
- Maintenance free
- Recommended temperature range -10°C to +50°C
- Protects actuators from torque damage
- Adjustable torque setting
- Technical information - see page T8-1
- Product overview - see pages 8-2 to 8-7



Contact us for product information, design support and custom solutions  
 sales@reliance.co.uk +44 (0) 1484 601002 www.reliance.co.uk



# 4 - 6 mm Bore

# Friction Clutch - Spiral Spring Set Screw Hub

All dimensions in mm  
General tolerances  $\pm 0.13$  mm

**Associated Products**  
Shafts: page 11-2  
Bearings: page 12-1  
Leadscrews: page 7-1  
Intelligent motors: page 2-2

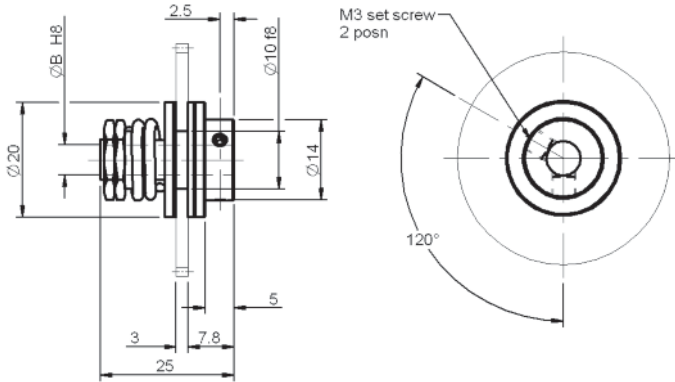

| H8        |           |
|-----------|-----------|
| Bore Size | Tolerance |
| 4         |           |
| 5         | +0.018    |
| 6         |           |

| f8        |                  |
|-----------|------------------|
| Shaft Dia | Tolerance        |
| 10        | -0.013<br>-0.035 |

## Part number selection and technical table

| Part Number   | Bore<br>$\varnothing B$ | Max Speed<br>$\text{min}^{-1}$ | Max Adjustable Torque<br>Ncm | Moment of Inertia<br>$\text{gcm}^2$ | Max Screw Torque<br>Ncm | Material                        |               | Approx Weight<br>g |
|---------------|-------------------------|--------------------------------|------------------------------|-------------------------------------|-------------------------|---------------------------------|---------------|--------------------|
|               |                         |                                |                              |                                     |                         | Flange                          | Clutch Lining |                    |
| RRKSS-2025-04 | 4                       |                                |                              |                                     |                         | Steel                           |               |                    |
| RRKSS-2025-05 | 5                       | 50                             | 30                           | 8.4                                 | 80                      | 9S Mn Pb 28<br>(Black finished) | Nylatron      | 23                 |
| RRKSS-2025-06 | 6                       |                                |                              |                                     |                         |                                 |               |                    |

Note: Gear not included, manufactured on request, please enquire

## Technical support

- Zero backlash before slipping
- Maintenance free
- Recommended temperature range  $-10^{\circ}\text{C}$  to  $+50^{\circ}\text{C}$
- Protects actuators from torque damage
- Adjustable torque setting
- Technical information - see page T8-1
- Product overview - see pages 8-2 to 8-7





# Friction Clutch - Plate Spring Clamp Hub

4 - 6 mm Bore



**Associated Products**  
 Shafts: page 11-2  
 Bearings: page 12-1  
 Leadscrews: page 7-1  
 Intelligent motors: page 2-2

All dimensions in mm  
 General tolerances  $\pm 0.13$  mm

| H8        |           |
|-----------|-----------|
| Bore Size | Tolerance |
| 4         | +0.018    |
| 5         |           |
| 6         |           |

| f8        |           |
|-----------|-----------|
| Shaft Dia | Tolerance |
| 10        | -0.013    |
|           | -0.035    |

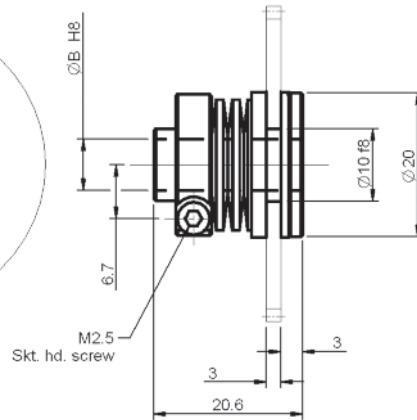
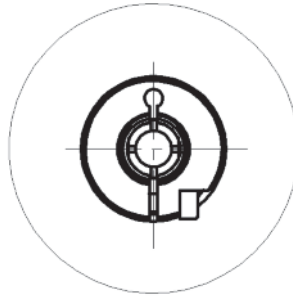

Couplings and Collars

## Technical specifications

| Part Number   | Bore<br>ØB | Max Speed<br>min <sup>-1</sup> | Max Adjustable Torque<br>Ncm | Moment of Inertia<br>gcm <sup>2</sup> | Max Screw Torque<br>Ncm | Material         |               | Approx Weight<br>g |
|---------------|------------|--------------------------------|------------------------------|---------------------------------------|-------------------------|------------------|---------------|--------------------|
|               |            |                                |                              |                                       |                         | Flange           | Clutch Lining |                    |
| RRKTK-2020-04 | 4          | 40                             | 120                          | 7                                     | 100                     | Steel            | Nylatron      | 23                 |
| RRKTK-2020-05 | 5          |                                |                              |                                       |                         | 9S Mn Pb 28      |               |                    |
| RRKTK-2020-06 | 6          |                                |                              |                                       |                         | (Black finished) |               |                    |

Note: Gear not included, manufactured on request, please enquire

## ? Technical support

- Zero backlash before slipping
- Maintenance free
- Recommended temperature range -10°C to +50°C
- Protects actuators from torque damage
- Adjustable torque setting
- Technical information - see page T8-1
- Product overview - see pages 8-2 to 8-7





# 4 - 6 mm Bore

# Friction Clutch - Plate Spring Set Screw Hub

All dimensions in mm  
General tolerances  $\pm 0.13$  mm

**Associated Products**  
Shafts: page 11-2  
Bearings: page 12-1  
Leadscrews: page 7-1  
Intelligent motors: page 2-2

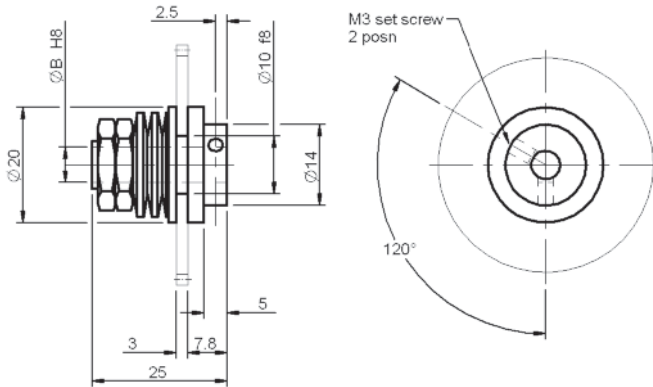

| H8        |           |
|-----------|-----------|
| Bore Size | Tolerance |
| 4         |           |
| 5         | +0.018    |
| 6         |           |

| f8        |                  |
|-----------|------------------|
| Shaft Dia | Tolerance        |
| 10        | -0.013<br>-0.035 |

## Technical specifications

| Part Number   | Bore<br>$\varnothing B$ | Max Speed<br>$\text{min}^{-1}$ | Max Adjustable Torque<br>Ncm | Moment of Inertia<br>$\text{gcm}^2$ | Max Screw Torque<br>Ncm | Material                        |               | Approx Weight<br>g |
|---------------|-------------------------|--------------------------------|------------------------------|-------------------------------------|-------------------------|---------------------------------|---------------|--------------------|
|               |                         |                                |                              |                                     |                         | Flange                          | Clutch Lining |                    |
| RRKTS-2025-04 | 4                       |                                |                              |                                     |                         | Steel                           |               |                    |
| RRKTS-2025-05 | 5                       | 40                             | 120                          | 9.9                                 | 80                      | 9S Mn Pb 28<br>(Black finished) | Nylatron      | 25                 |
| RRKTS-2025-06 | 6                       |                                |                              |                                     |                         |                                 |               |                    |

Note: Gear not included, manufactured on request, please enquire

## ? Technical support

- Zero backlash before slipping
- Maintenance free
- Recommended temperature range  $-10^{\circ}\text{C}$  to  $+50^{\circ}\text{C}$
- Protects actuators from torque damage
- Adjustable torque setting
- Technical information - see [page T8-1](#)
- Product overview - see [pages 8-2 to 8-7](#)





### Associated Products

Shafts: page 11-2  
 Bearings: page 12-1  
 Leadscrews: page 7-1  
 Intelligent motors: page 2-2

All dimensions in mm  
 Materials: Aluminium alloy  
 grade 2024 T351  
 Stainless steel  
 Grade 18.8 type 303  
 Screws C12L14

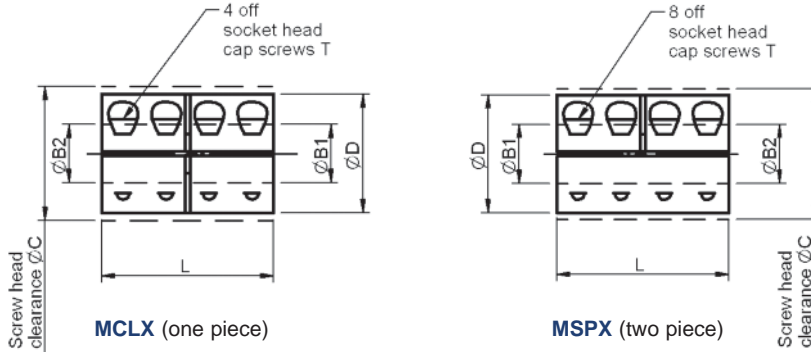

Couplings and Collars

### Part number selection table

| Example Part No:-<br><b>MCLX - A - 3-3</b> |                   |          | Dimensions<br>(mm)                            |     |        |               |    |
|--|-------------------|----------|---|-----|--------|---------------|----|
| Basic Part Number                          | Material          | Size Ref | Standard Bore Sizes                           | O/D | Length | Clamp Screw T |    |
|  |                   |          | ØB1 and ØB2<br>(bore tolerance +0.012/+0.050) | ØD  | L      |               | ØC |
| <b>MCLX</b><br>(1-piece)                   | A*<br>(Aluminium) | 3        | 3   | 15  | 22     | 15.0          | M2 |
|  |                   | 4        | 4   | 15  | 22     | 15.0          | M2 |
|  |                   | 5        | 5   | 15  | 22     | 15.0          | M2 |
| <b>MSPX</b><br>(2-piece)                   | SS<br>(St. steel) | 6        | 6   | 18  | 30     | 21.5          | M3 |
|  |                   | 8        | 8   | 24  | 35     | 27.1          | M3 |
|  |                   | 10       | 10  | 29  | 45     | 33.0          | M4 |

\*Aluminium is only available on MCLX

### **i** Product options

- Alternative bore sizes
- Imperial bores
- Set screw clamping
- Stainless steel screws



### **?** Technical support

- Does not mark the shaft
- Nypatch® anti-vibration hardware
- Precision honed bore
- MSPX, two piece style is balanced by opposing hardware and is easily disassembled and maintained
- Max speed: 4,000 rpm
- Recommended temperature range:  
 Stainless steel -40°C to +175°C  
 Aluminium -40°C to +100°C
- Technical information - see page T8-1
- Installation information - see page T8-4
- Product overview - see pages 8-2 to 8-7



# 6 - 10 mm Bore

# Double Width Shaft Clamp Collars

All dimensions in mm  
 Materials: Aluminium alloy  
 grade 2024 T351  
 Stainless steel  
 Grade 18.8 type 303  
 Screws C12L14

**Associated Products**  
 Shafts: page 11-2  
 Bearings: page 12-1  
 Leadscrews: page 7-1  
 Intelligent motors: page 2-2

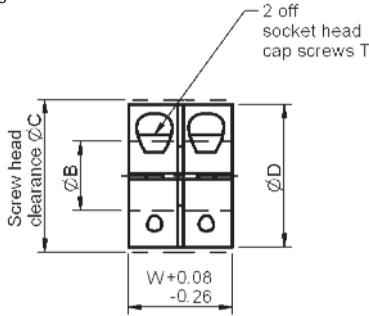

**MWCL** (one piece)

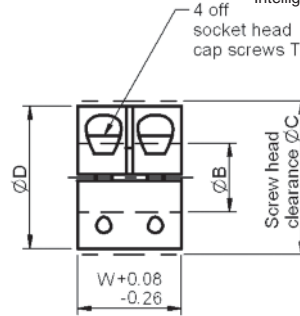

**MWSP** (two piece)

## Part number selection table

| Example Part No:-<br><b>MWCL - A - 6</b> |                          |           | Dimensions<br>(mm)  |           |            |      |                  |
|--|--------------------------|-----------|---|-----------|------------|------|------------------|
| Basic Part Number                        | Material                 | Size      | Standard Bore Sizes<br>ØB<br>(bore tolerance +0.012/+0.050) | O/D<br>ØD | Width<br>W | ØC   | Clamp Screw<br>T |
| <b>MWCL</b><br>(1-piece)                 | <b>A*</b><br>(Aluminium) | <b>6</b>  | 6   | 16        | 20         | 20.8 | M3               |
| <b>MWSP</b><br>(2-piece)                 | <b>SS</b><br>(St. steel) | <b>8</b>  | 8   | 18        | 20         | 22.4 | M3               |
|  |                          | <b>10</b> | 10  | 24        | 20         | 26.3 | M3               |

\*Aluminium is only available on MWCL

### **i** Product options

- Alternative bore sizes
- Imperial bores
- Set screw clamping
- Stainless steel screws



### **?** Technical support

- Does not mark the shaft
- Integral location face
- Excellent for high axial loads
- MWSP, two piece style is balanced by opposing hardware and is easily disassembled and maintained
- Transmits torque in confined spaces
- Recommended temperature range:  
 Stainless steel -40°C to +175°C  
 Aluminium -40°C to +100°C
- Installation information - see page T8-4
- Product overview - see pages 8-2 to 8-7

# Shaft Clamp Collars

3 - 10 mm Bore



## Associated Products

Shafts: page 11-2  
 Bearings: page 12-1  
 Leadscrews: page 7-1  
 Intelligent motors: page 2-2

All dimensions in mm  
 Materials: Aluminium alloy  
 grade 2024 T351  
 sulphuric anodised  
 Stainless steel  
 Grade 18.8 type 303  
 Screws C12L14

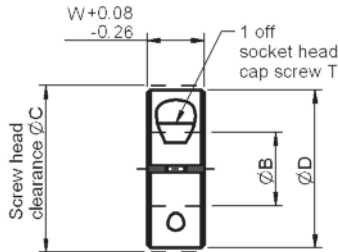

MCL (one piece)

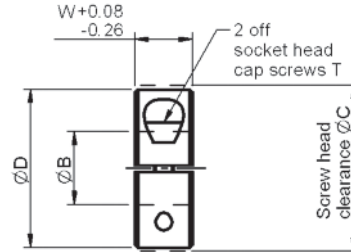

MSP (two piece)

## Part number selection table

| Example Part No:-<br>MCL - A - 3 |                   |      | Dimensions<br>(mm)  |           |            |      |                  |
|----------------------------------|-------------------|------|---|-----------|------------|------|------------------|
| Basic Part Number                | Material          | Size | Standard Bore Sizes<br>ØB<br>(bore tolerance +0.012/+0.050) | O/D<br>ØD | Width<br>W | ØC   | Clamp Screw<br>T |
| MCL<br>(1-piece)                 | A<br>(Aluminium)  | 3    | 3   | 16        | 9          | 20.8 | M3               |
|                                  |                   | 4    | 4   | 16        | 9          | 20.8 | M3               |
|                                  |                   | 5    | 5   | 16        | 9          | 20.8 | M3               |
|                                  |                   | 6    | 6   | 16        | 9          | 20.8 | M3               |
| MSP<br>(2-piece)                 | SS<br>(St. steel) | 7    | 7   | 18        | 9          | 22.4 | M3               |
|                                  |                   | 8    | 8   | 18        | 9          | 22.4 | M3               |
|                                  |                   | 9    | 9   | 24        | 9          | 26.3 | M3               |
|                                  |                   | 10   | 10  | 24        | 9          | 26.3 | M3               |

### Product options

- Alternative bore sizes
- Imperial bores
- Stainless steel screws
- Plastic collars available
- 316 stainless steel available



### Technical support

- Does not mark shaft
- Integral location face
- MSP, two piece style is balanced by opposing hardware and is easily disassembled and maintained
- Pre-drilled face holes
- Recommended temperature range:  
 Stainless steel -40°C to +175°C  
 Aluminium -40°C to +90°C
- Installation information - see page T8-4
- Product overview - see pages 8-2 to 8-7

Couplings  
and Collars



# 4 - 10 mm Bore

# One Piece Threaded Collars

All dimensions in mm  
 Material: Stainless steel  
 grade 18.8 type 303  
 Screws C12L14

**Associated Products**  
 Shafts: page 11-2  
 Bearings: page 12-1  
 Leadscrews: page 7-1  
 Intelligent motors: page 2-2

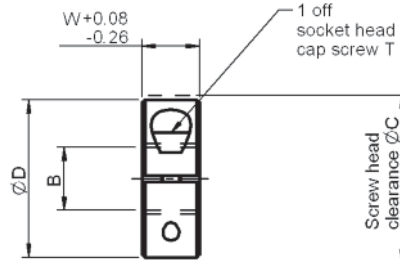

**MTCL** (threaded)

## Part number selection table

| Example Part No:-<br>MTCL - SS - 4 |                   |      | Dimensions<br>(mm)    |     |       |               |    |
|------------------------------------|-------------------|------|-----------------------|-----|-------|---------------|----|
| Basic Part Number                  | Material          | Size | Standard Thread Sizes | O/D | Width | Clamp Screw T |    |
|                                    |                   |      | B                     | ØD  | W     |               | ØC |
| MTCL                               | SS<br>(St. steel) | 4    | M4x0.7                | 16  | 9     | 20.8          | M3 |
|                                    |                   | 5    | M5x0.8                | 16  | 9     | 20.8          | M3 |
|                                    |                   | 6    | M6x1                  | 16  | 9     | 20.8          | M3 |
|                                    |                   | 8    | M8x1.25               | 18  | 9     | 22.4          | M3 |
|                                    |                   | 10   | M10x1.5               | 24  | 9     | 26.3          | M3 |



### **i** Product options

- Alternative thread sizes
- Imperial threads
- Stainless steel screws
- Acme and left-hand threads available
- Additional sizes available

### **?** Technical support

- Does not mark shaft
- Integral location face
- Installation information - see page T8-4
- Product overview - see pages 8-2 to 8-7

# One Piece Set Screw Collars

4 - 10 mm Bore



**Associated Products**  
 Shafts: page 11-2  
 Bearings: page 12-1  
 Leadscrews: page 7-1  
 Intelligent motors: page 2-2

All dimensions in mm  
 Material: Stainless steel  
 grade 18.8 type 303  
 Screws C12L14

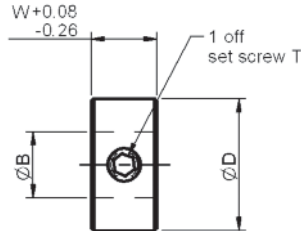

**MSC** (set screw)

## Part number selection table

| Example Part No:-<br><b>MSC - SS - 4</b> |                          |           | Dimensions<br>(mm)  |           |            |                |
|--|--------------------------|-----------|---|-----------|------------|----------------|
| Basic Part Number                        | Material                 | Size      | Standard Bore Sizes<br>ØB<br>(bore tolerance +0.012/+0.050) | O/D<br>ØD | Width<br>W | Set Screw<br>T |
| <b>MSC</b>                               | <b>SS</b><br>(St. steel) | <b>4</b>  | 4   | 8         | 5          | M2.5X3         |
|  |                          | <b>5</b>  | 5   | 10        | 6          | M3X4           |
|  |                          | <b>6</b>  | 6   | 12        | 8          | M4X4           |
|  |                          | <b>8</b>  | 8   | 16        | 8          | M4X4           |
|  |                          | <b>10</b> | 10  | 20        | 10         | M5X5           |

Couplings and Collars



### **i** Product options

- Alternative bore sizes
- Imperial bores
- Stainless steel screws
- Plastic collars available

### **?** Technical support

- Forged socket set screw
- Installation information - see page T8-4
- Product overview - see pages 8-2 to 8-7





## Section Contents

|   |           |
|---|-----------|
| Linear Guides and Slides - Overview ..... | Page 9-2  |
| Spline Shafts .....                       | Page 9-4  |
| Linear Rails .....                        | Page 9-6  |
| Miniature Linear Guide Series.....        | Page 9-7  |
| Miniature Stroke Slides .....             | Page 9-12 |
| Ball and Crossed Roller Slides .....      | Page 9-14 |
| Rack Driven Ballslides .....              | Page 9-16 |
| Technical Information.....                | Page T9-1 |



## Low friction linear motion

The Reliance range of precision slides and guides provides a variety of linear actuation solutions for loads up to 12,580 N and with lengths in excess of 1 metre. The range includes miniature linear guides, stroke slides, roller slides, rack driven ball slides and linear rails, together with spline shafts which provide both linear and rotary motion.

### Miniature linear guides

The linear guides consist of a stainless steel rail with a unique re-circulating ball design in the carriage, which delivers smooth motion, low noise and high accuracy. The guides provide high levels of stiffness to enable the carriage to operate at higher speeds and with a 45° contact angle and a gothic profile design incorporated into the carriage, resulting in an equal load capacity in all directions, they provide high load and moment capacity. With their built-in lubrication reservoirs they provide an effective, low maintenance solution, further enhanced by specially designed seals to prevent dust and foreign objects from entering the system.



Linear guides are available with 3 mm to 15 mm wide rails and lengths up to 870 mm, offered in standard sizes or custom lengths, with carriages available in a variety of widths and lengths. Options are available for both lubrication and seals, with different mounting options accommodated via tapped or counter-bored mounting holes, and options for accuracies and pre-loading of the bearings where additional stiffness and precision are required.

Reliance's cut-to-length capability means that customers can order small quantities and samples for product trials or prototyping on a reduced lead-time.

### Miniature stroke slides

The miniature stroke slide offers a compact alternative to the linear guides for applications where a short stroke length is required, making it an ideal choice for a smaller space envelope. They are available in 7 mm to 12 mm wide rails and up to 100 mm length rails, providing up to 94 mm travel length. The stroke slides possess many of the same characteristics as the linear guides however there is no ball re-circulation, rather the balls roll on rails resulting in smooth motion, low friction and high accuracy without vibration.



The linear guides and stroke slides are ideal for use in a linear actuation system, used in conjunction with the Cool Muscle intelligent motor and leadscrews or rack and pinions, to provide stable, accurate load movement.

### Ball and crossed roller

Ball and crossed roller slides provide very low friction linear motion in a compact package, with a high load carrying capacity, long life and high accuracy. They are similar to the miniature stroke slides, but available with rails from 4 mm to 38.1 mm widths and up to 381 mm lengths. The ball slides are also



available in a rack driven configuration suitable for controlled motion with a rack and pinion drive system. Rack driven ball slides are ideal for measuring position, driving a mechanism, or both, and can be used at very high speeds and loads.



### Linear rails

Linear rails offer a low cost option for systems where light loads are used. The linear rails exhibit a minimal frictional drag and long wear characteristics. They consist of a stainless steel shaft and composite polymer bushing, available with shaft diameters from approximately 6 mm to 19 mm and lengths up to 3,600 mm.

### Spline shafts

Spline shafts are suited to light to moderate load applications, where low cost, low friction and long life are the primary design considerations. They provide anti-rotation for one axis motion or a drive mechanism for two axes of motion. The assembly consists of a stainless steel spline shaft treated with low friction TFE coating together with a free-running or anti-backlash composite polymer bushing. Shafts are available in diameters from 3.18 mm to 19.05 mm, with lengths up to 3,600 mm. Bushings are supplied with an integral brass collar to facilitate various mounting configurations without nut distortion. Spline shafts are offered with a wide range of options including alternative materials, end modifications, multiple bushings and bushing modifications. An anti-backlash assembly is available for applications requiring minimum torsional play.



The range of slides and guides are suitable for a variety of applications including accurate XY stages, medical and laboratory automation and scientific analysis equipment.



Customised XYZ positioning table



Laboratory automation assembly



All dimensions in mm  
General tolerances  $\pm 0.13$  mm  
Material: See page 9-5

**Associated Products**  
Leadscrews: page 7-1  
Hardware: page 13-1

Linear Guides  
and Slides

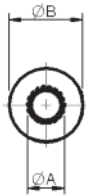

**SRSSBP**  
(Free running)

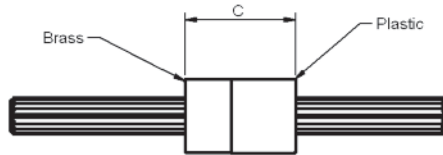

**SRSSBY**  
(Free running)

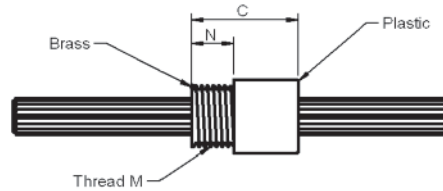

**SRSSZP**  
(Anti-backlash)

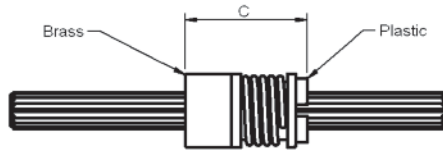

**SRSSZY**  
(Anti-backlash)

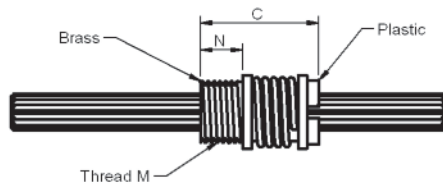



## Part number selection table

Example Part No:- **SRSS B P 6 T 1 - 100mm**

Number of bushings: 6  
TFE coating (standard): 1

| Basic Part No. | Bushing Style        | Mount            | Size Code | Shaft Dia ØA**<br>±0.05 mm | Bushing Outside Dia ØB<br>±0.025 mm | Bushing Length C<br>±0.25 mm | Thread M*<br>(Inch) | Thread Length N*<br>±0.05 mm | Max Length |
|----------------|----------------------|------------------|-----------|----------------------------|-------------------------------------|------------------------------|---------------------|------------------------------|------------|
| SRSS           | B<br>(Free running)  | P<br>(Plain Dia) | 3         | 3.18                       | 9.53                                | 12.7                         | 3/8-24              | 6.35                         | 900        |
|                |                      |                  | 6         | 6.35                       | 12.70                               | 19.1                         | 7/16-20             | 6.35                         | 2400       |
|                | Z<br>(Anti-backlash) | Y<br>(Thread)    | 10        | 9.53                       | 15.88                               | 25.4                         | 9/16-20             | 9.53                         | 2400       |
|                |                      |                  | 13        | 12.70                      | 20.65                               | 38.1                         | 3/4-20              | 12.70                        | 2400       |
|                |                      |                  | 19        | 19.05                      | 28.58                               | 57.2                         | 1-16                | 19.05                        | 3600       |

Note: Code size **19** is only available in material 14L14 carbon steel.

\* Only on thread mounting spline shafts.

\*\* 3.18 mm shaft diameter only available in SRSSBP and SRSSBY styles.

Note: Due to the process of manufacture, a small number of localised hollows and hard spots may be created. This will not affect the overall function or performance.

Linear Guides and Slides

### **i** Product options

- Lengths up to 3,600 mm available
- Larger number of bushings
- Bush modifications
- End modifications
- Available in aluminium, please contact us



### **?** Technical support

- Material:
  - Spline shaft - Stainless steel, TFE coated
  - Bushing - Graphite filled PTFE thermoplastic with brass collar
- Standard shaft straightness is 0.076 mm per 305 mm
- Typical radial clearance between shaft and bushing for free running assembly is 0.05 to 0.076 mm. Anti-backlash assemblies provide additional system stiffness
- Designed for light load applications
- Maximum twist 3°/305 mm
- Torsional clearance 3° bushing to shaft
- Product overview - see pages 9-2 to 9-3



All dimensions in mm  
 General tolerances  $\pm 0.13$  mm  
 Material: Rail - Stainless steel  
 Bushing - Composite polymer

**Associated Products**  
 Leadscrews: page 7-1  
 Hardware: page 13-1

The linear rail system has been designed for light load applications where low cost, minimum frictional drag and long wear life are primary design considerations - Product overview - see pages 9-2 to 9-3

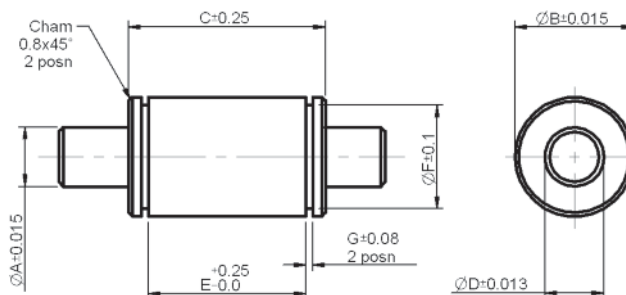

## Part number selection table

**Example Part No:-** **RGR B P 6 T 1 - 100mm**

RGR: Basic Part No.  
 B: Bushing Style  
 P: Mount Style  
 6: Size Code  
 T: Rail Dia  $\varnothing A^{**}$   
 1: Bushing OD  $\varnothing B$   
 100mm: Shaft length, (max length 3600 mm)  
 (Number of bushings)  
 (TFE coating (standard))

| Basic Part No. | Bushing Style | Mount Style | Size Code | Rail Dia $\varnothing A^{**}$ | Bushing OD $\varnothing B$ | C     | Bushing Bore Dia $\varnothing D$ | Width E | Groove F | G    | Radial Load Kg |
|----------------|---------------|-------------|-----------|-------------------------------|----------------------------|-------|----------------------------------|---------|----------|------|----------------|
| RGR            | B             | P           | 6         | 6.279                         | 12.70                      | 19.43 | 6.311                            | 13.59   | 11.43    | 1.02 | 2.3            |
|                |               |             | 10        | 9.428                         | 19.05                      | 32.39 | 9.462                            | 25.27   | 17.17    | 1.17 | 4.5            |
|                |               |             | 13        | 12.603                        | 25.40                      | 42.16 | 12.637                           | 33.78   | 22.86    | 1.17 | 6.8            |
|                |               |             | 19        | 18.826                        | 31.75                      | 51.72 | 18.860                           | 41.15   | 28.60    | 1.47 | 11.4           |

\*\* Including TFE coating.

## Technical support

- The assembly consists of a centreless ground and burnished stainless steel shaft mated with a composite polymer bushing
- The material combinations have been selected so that the thermal fluctuations have minimal effect on system performance
- Standard shaft straightness is 0.05 mm per 300 mm
- Standard typical radial clearance between shaft and bearings on TFE coated assemblies is 0.025 mm
- Bushings are manufactured with standard retaining ring grooves





### Reinforced design for high speed running

During operation, the steel balls generate an impact force on the end caps when direction of motion changes. The RMR miniature design includes an embedded plastic inverse hook that tightly secures the carriage components and absorbs these impact forces. The high speed running capability of our linear guides has increased in line with the demands of rapid motion automation.

### Unique ball re-circulation design

The stainless steel ball re-circulation channels are sealed by plastic end caps, resulting in low noise during operation. The design of the lubricant store, which is embedded within the re-circulation channel, reduces the frequency of lubrication.



### Bottom seal

The bottom seal, available on sizes 9, 12 and 15, prevents foreign objects entering the carriage assembly. The life of the carriage and rail is increased while running smoothness is uncompromised.



### Stainless steel reinforcement plates

The plastic end caps are entirely encased by two stainless steel reinforced plates secured in place with stainless steel screws. The increased stiffness allows the carriage to operate at higher speeds.



### Lubrication reservoir design

Lubrication is injected via holes located at both ends of the carriage and carried efficiently to the raceways by means of the re-circulating balls, thus increasing the maintenance intervals.



### High load and moment capacity

The miniature linear guide series incorporates a gothic profile design with a 45° contact angle, providing equal load capacity in all directions. Large steel balls have been designed into limited space to provide enhanced load bearing and torsional resistance.

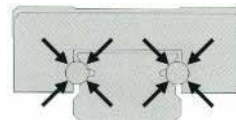

### Dust proof design

Specially designed end seals prevent dust and foreign objects entering the system, increasing the product life. These seals are low friction and do not effect the smooth running of the linear guide.



Linear Guides  
and Slides



# Standard RMR Series

# Miniature Linear Guides

All dimensions in mm  
 General tolerances  $\pm 0.13$  mm  
 Material: Stainless steel

**Associated Products**  
 Set screws: page 13-11  
 Machine screws: page 13-2

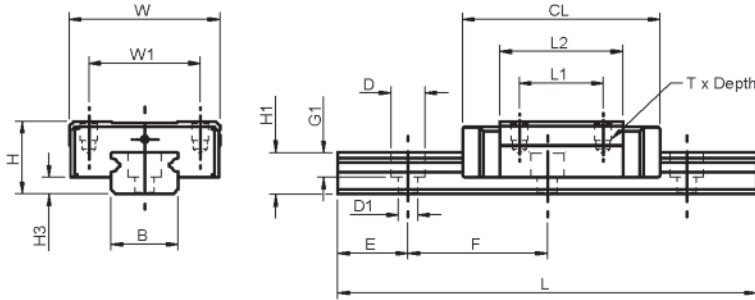

## Part number selection table

| Basic Part Number | Max Travel | Carriage Dimensions |         |           | Max Rail Length | Load Rating          |                     |                     |       |       |
|-------------------|------------|---------------------|---------|-----------|-----------------|----------------------|---------------------|---------------------|-------|-------|
|                   |            | Height H            | Width W | Length CL |                 | Basic Dynamic Load N | Basic Static Load N | Static Moment Loads |       |       |
|                   |            |                     |         |           |                 |                      |                     | To Nm               | Tx Nm | Ty Nm |
| RMRU3-MNSS-       | 286.3      | 4                   | 8       | 11.7      | 300             | 190                  | 310                 | 0.6                 | 0.4   | 0.4   |
| RMR5-MNSS-        | 981.3      | 6                   | 12      | 16.0      | 1,000           | 335                  | 550                 | 1.7                 | 1.0   | 1.0   |
| RMR7-MNSS-        | 974.3      | 8                   | 17      | 23.7      | 1,000           | 890                  | 1,400               | 5.2                 | 3.3   | 3.3   |
| RMR9-MNSS-        | 967.4      | 10                  | 20      | 30.6      | 1,000           | 1570                 | 2,495               | 11.7                | 6.4   | 6.4   |
| RMR12-MNSS-       | 962.6      | 13                  | 27      | 35.4      | 1,000           | 2308                 | 3,465               | 21.5                | 12.9  | 12.9  |
| RMR15-MNSS-       | 955        | 16                  | 32      | 43.0      | 1,000           | 3810                 | 5,590               | 43.6                | 27.0  | 27.0  |
| RMRU3-MLSS-       | 282        | 4                   | 8       | 16.0      | 300             | 295                  | 575                 | 0.9                 | 1.1   | 1.1   |
| RMR5-MLSS-        | 976.8      | 6                   | 12      | 19.6      | 1,000           | 470                  | 900                 | 2.4                 | 2.1   | 2.1   |
| RMR7-MLSS-        | 966.8      | 8                   | 17      | 31.2      | 1,000           | 1,310                | 2,440               | 9.0                 | 7.7   | 7.7   |
| RMR9-MLSS-        | 957.1      | 10                  | 20      | 40.9      | 1,000           | 2,135                | 3,880               | 18.2                | 12.4  | 12.4  |
| RMR12-MLSS-       | 950.4      | 13                  | 27      | 47.6      | 1,000           | 3,240                | 5,630               | 34.9                | 30.2  | 30.2  |
| RMR15-MLSS-       | 938        | 16                  | 32      | 60.0      | 1,000           | 5,350                | 9,080               | 70.0                | 63.3  | 63.3  |

## Part number structure

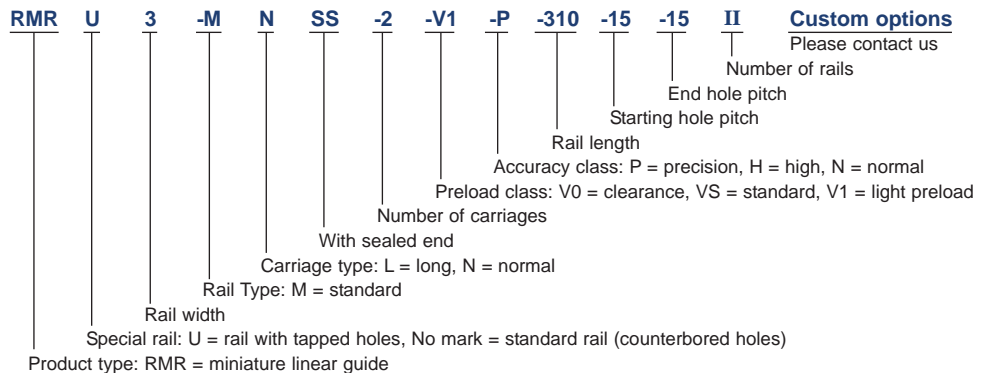





### Dimensions

| Basic Part Number  | Rail Dimensions |        |                 | Carriage Dimensions |        |            |      |      |
|--------------------|-----------------|--------|-----------------|---------------------|--------|------------|------|------|
|                    | Width           | Height | Mounting Hole   | Mounting Length     | Height | Thread     | Ctrs | Ctrs |
|                    | B               | H1     | D x D1 x G1     | L2                  | H3     | T x Depth  | L1   | W1   |
| <b>RMRU3-MNSS-</b> | 3               | 2.6    | M1.6            | 6.7                 | 1.0    | M1.6 x 1.1 | 3.5  | -    |
| <b>RMR5-MNSS-</b>  | 5               | 3.5    | 3.5 x 2.4 x 1   | 10.0                | 1.5    | M2 x 1.5   | -    | 8    |
| <b>RMR7-MNSS-</b>  | 7               | 4.7    | 4.2 x 2.4 x 2.3 | 14.3                | 1.5    | M2 x 2.5   | 8    | 12   |
| <b>RMR9-MNSS-</b>  | 9               | 5.5    | 6 x 3.5 x 3.5   | 20.5                | 2.2    | M3 x 3.0   | 10   | 15   |
| <b>RMR12-MNSS-</b> | 12              | 7.5    | 6 x 3.5 x 4.5   | 22.0                | 3.0    | M3 x 3.5   | 15   | 20   |
| <b>RMR15-MNSS-</b> | 15              | 9.5    | 6 x 3.5 x 4.5   | 27.0                | 4.0    | M3 x 5.5   | 20   | 25   |
| <b>RMRU3-MLSS-</b> | 3               | 2.6    | M1.6            | 11.0                | 1.0    | M2 x 1.1   | 5.5  | -    |
| <b>RMR5-MLSS-</b>  | 5               | 3.5    | 3.5 x 2.4 x 1   | 13.5                | 1.5    | M2.6 x 2.0 | 7    | -    |
| <b>RMR7-MLSS-</b>  | 7               | 4.7    | 4.2 x 2.4 x 2.3 | 21.8                | 1.5    | M2 x 2.5   | 13   | 12   |
| <b>RMR9-MLSS-</b>  | 9               | 5.5    | 6 x 3.5 x 3.5   | 30.8                | 2.2    | M3 x 3.0   | 16   | 15   |
| <b>RMR12-MLSS-</b> | 12              | 7.5    | 6 x 3.5 x 4.5   | 34.0                | 3.0    | M3 x 3.5   | 20   | 20   |
| <b>RMR15-MLSS-</b> | 15              | 9.5    | 6 x 3.5 x 4.5   | 44.0                | 4.0    | M3 x 5.5   | 25   | 25   |

### Available standard lengths (mm)

| Size                                  | 3M | 5M  | 7M  | 9M  | 12M | 15M |
|---------------------------------------|----|-----|-----|-----|-----|-----|
| Standard Length of One Rail (mm)<br>L | 30 | 40  | 40  | 55  | 70  | 70  |
|                                       | 40 | 55  | 55  | 75  | 95  | 110 |
|                                       | 50 | 70  | 70  | 95  | 120 | 150 |
|                                       |    | 85  | 85  | 115 | 145 | 190 |
|                                       |    | 100 | 100 | 135 | 170 | 230 |
|                                       |    |     |     | 130 | 155 | 270 |
|                                       |    |     |     | 175 | 220 | 310 |
|                                       |    |     |     | 195 | 245 | 350 |
|                                       |    |     |     | 275 | 270 | 390 |
|                                       |    |     |     | 375 | 320 | 430 |
|                                       |    |     |     |     | 370 | 470 |
|                                       |    |     |     |     | 470 | 550 |
|                                       |    |     |     |     | 570 | 670 |
|                                       |    |     |     |     | 870 |     |
| Pitch F                               | 10 | 15  | 15  | 20  | 25  | 40  |
| E Min                                 | 3  | 3   | 3   | 4   | 4   | 4   |
| E Max                                 | 5  | 10  | 10  | 20  | 20  | 35  |

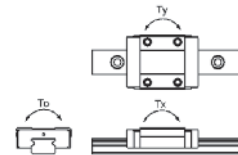

Linear Guides and Slides

### **i** Product options

- End seal plus reinforcement plate on sizes 9, 12 and 15. Replace **-SS** with **-EE**
- End seal plus lubrication reservoir on all sizes. Replace **-SS** with **-ZZ**
- Bottom and end seals. Replace **-SS** with **-EU**
- Bottom seal, end seal and lubrication reservoir. Replace **-SS** with **-UZ**
- Customised design, including cut to length

### **?** Technical support

- Key features - see page 9-7
- Technical information - see page T9-3
- Joining guides for longer lengths - see page T9-3
- Product overview - see pages 9-2 to 9-3



# Wide RMR Series

# Miniature Linear Guides

All dimensions in mm  
 General tolerances  $\pm 0.13$  mm  
 Material: Stainless steel

**Associated Products**  
 Set screws: page 13-11  
 Machine screws: page 13-2

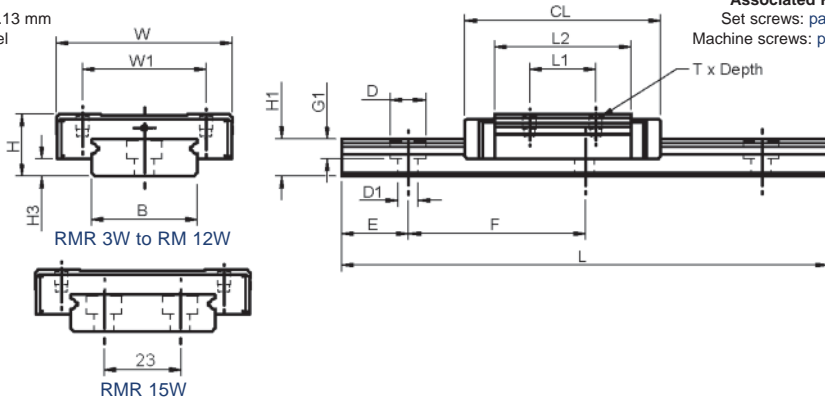

## Part number selection table

| Basic Part Number | Max Travel | Carriage Dimensions |         |           | Max Rail Length | Load Rating          |                     |                     |       |       |
|-------------------|------------|---------------------|---------|-----------|-----------------|----------------------|---------------------|---------------------|-------|-------|
|                   |            | Height H            | Width W | Length CL |                 | Basic Dynamic Load N | Basic Static Load N | Static Moment Loads |       |       |
|                   |            |                     |         |           |                 |                      |                     | To Nm               | Tx Nm | Ty Nm |
| RMR3-WNSS-        | 983.0      | 4.5                 | 12      | 15        | 1,000           | 280                  | 530                 | 1.6                 | 0.9   | 0.9   |
| RMR5-WNSS-        | 976.9      | 6.5                 | 17      | 21.1      |                 | 475                  | 900                 | 4.6                 | 2.2   | 2.2   |
| RMR7-WNSS-        | 966.4      | 9.0                 | 25      | 31.6      |                 | 1,180                | 2,095               | 15.0                | 7.3   | 7.3   |
| RMR9-WNSS-        | 958.9      | 12.0                | 30      | 39.1      |                 | 2,030                | 3,605               | 33.2                | 13.7  | 13.7  |
| RMR12-WNSS-       | 953.6      | 14.0                | 40      | 44.4      |                 | 3,065                | 5,200               | 63.7                | 26.3  | 26.3  |
| RMR15-WNSS-       | 942.7      | 16.0                | 60      | 55.3      | 5,065           | 8,385                | 171.7               | 45.7                | 45.7  |       |
| RMR3-WLSS-        | 977.9      | 4.5                 | 12      | 20.1      | 1,000           | 370                  | 800                 | 2.5                 | 1.9   | 1.9   |
| RMR5-WLSS-        | 970.8      | 6.5                 | 17      | 27.2      |                 | 615                  | 1,315               | 6.8                 | 4.1   | 4.1   |
| RMR7-WLSS-        | 957.5      | 9.0                 | 25      | 40.5      |                 | 1,570                | 3,140               | 22.65               | 14.9  | 14.9  |
| RMR9-WLSS-        | 947.3      | 12.0                | 30      | 50.7      |                 | 2,550                | 4,990               | 45.9                | 26.7  | 26.7  |
| RMR12-WLSS-       | 938.6      | 14.0                | 40      | 59.4      |                 | 4,070                | 7,800               | 95.6                | 56.4  | 56.4  |
| RMR15-WLSS-       | 923.6      | 16.0                | 60      | 74.4      |                 | 6,725                | 12,580              | 257.6               | 93.1  | 93.1  |

## Part number structure

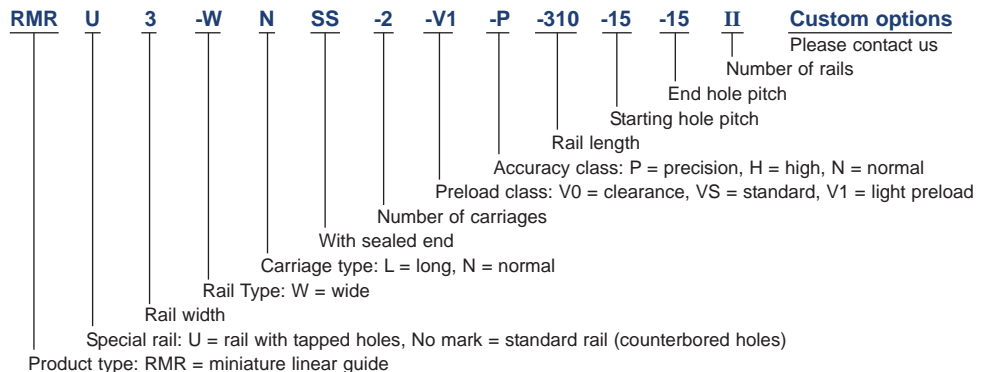



### Dimensions

| Basic Part Number  | Rail Dimensions |        |               | Carriage Dimensions |        |            |      |      |
|--------------------|-----------------|--------|---------------|---------------------|--------|------------|------|------|
|                    | Width           | Height | Mounting Hole | Mounting Length     | Height | Thread     | Ctrs | Ctrs |
|                    | B               | H1     | D x D1 x G1   | L2                  | H3     | T x Depth  | L1   | W1   |
| <b>RMR3-WNSS-</b>  | 6               | 2.7    | 4 x 2.4 x 1.5 | 10.0                | 1.0    | M2 x 1.4   | 4.5  | -    |
| <b>RMR5-WNSS-</b>  | 10              | 4.0    | 5.5 x 3 x 1.6 | 15.1                | 1.5    | M2.5 x 1.5 | 6.5  | 13   |
| <b>RMR7-WNSS-</b>  | 14              | 5.2    | 6 x 3.5 x 3.5 | 21.2                | 2.0    | M3 x 3     | 10.0 | 19   |
| <b>RMR9-WNSS-</b>  | 18              | 7.3    | 6 x 3.5 x 4.5 | 27.9                | 3.4    | M3 x 3     | 12.0 | 21   |
| <b>RMR12-WNSS-</b> | 24              | 8.5    | 8 x 4.5 x 4.5 | 31.0                | 3.9    | M3 x 3.5   | 15.0 | 28   |
| <b>RMR15-WNSS-</b> | 42              | 9.5    | 8 x 4.5 x 4.5 | 38.5                | 4.0    | M4 x 4.5   | 20.0 | 45   |
| <b>RMR3-WLSS-</b>  | 6               | 2.7    | 4 x 2.4 x 1.5 | 15.1                | 1.0    | M2 x 1.4   | 8.0  | -    |
| <b>RMR5-WLSS-</b>  | 10              | 4.0    | 5.5 x 3 x 1.6 | 21.2                | 1.5    | M2.5 x 1.5 | 11.0 | 13   |
| <b>RMR7-WLSS-</b>  | 14              | 5.2    | 6 x 3.5 x 3.5 | 30.1                | 2.0    | M3 x 3     | 19.0 | 19   |
| <b>RMR9-WLSS-</b>  | 18              | 7.3    | 6 x 3.5 x 4.5 | 39.5                | 3.4    | M3 x 3     | 24.0 | 23   |
| <b>RMR12-WLSS-</b> | 24              | 8.5    | 8 x 4.5 x 4.5 | 46.0                | 3.9    | M3 x 3.5   | 28.0 | 28   |
| <b>RMR15-WLSS-</b> | 42              | 9.5    | 8 x 4.5 x 4.5 | 57.6                | 4.0    | M4 x 4.5   | 35.0 | 45   |

### Available standard lengths

| Size                                  | 3W | 5W  | 7W  | 9W  | 12W | 15W |
|---------------------------------------|----|-----|-----|-----|-----|-----|
| Standard Length of One Rail (mm)<br>L | 40 | 50  | 50  | 50  | 70  | 110 |
|                                       | 55 | 70  | 80  | 80  | 110 | 150 |
|                                       | 70 | 90  | 110 | 110 | 150 | 190 |
|                                       |    | 110 | 140 | 140 | 190 | 230 |
|                                       |    | 130 | 170 | 170 | 230 | 270 |
|                                       |    | 150 | 200 | 200 | 270 | 310 |
|                                       |    | 170 | 260 | 260 | 310 | 430 |
|                                       |    |     | 290 | 290 | 390 | 550 |
|                                       |    |     |     | 320 | 470 | 670 |
|                                       |    |     |     |     | 550 | 790 |
| Pitch F                               | 15 | 20  | 30  | 30  | 40  | 40  |
| E Min                                 | 3  | 4   | 3   | 4   | 4   | 4   |
| E Max                                 | 10 | 15  | 25  | 25  | 35  | 35  |

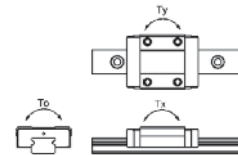

Linear Guides and Slides

### **i** Product options

- End seal plus reinforcement plate on sizes 9, 12 and 15. Replace **-SS** with **-EE**
- End seal plus lubrication reservoir on all sizes. Replace **-SS** with **-ZZ**
- Bottom and end seals. Replace **-SS** with **-EU**
- Bottom seal, end seal and lubrication reservoir. Replace **-SS** with **-UZ**
- Customised design, including cut to length

### **?** Technical support

- Key features - see page 9-7
- Technical information - see page T9-3
- Joining guides for longer lengths - see page T9-3
- Product overview - see pages 9-2 to 9-3



All dimensions in mm  
 General tolerances  $\pm 0.13$  mm  
 Material: Stainless steel

**Associated Products**  
 Set screws: page 13-11  
 Machine screws: page 13-2

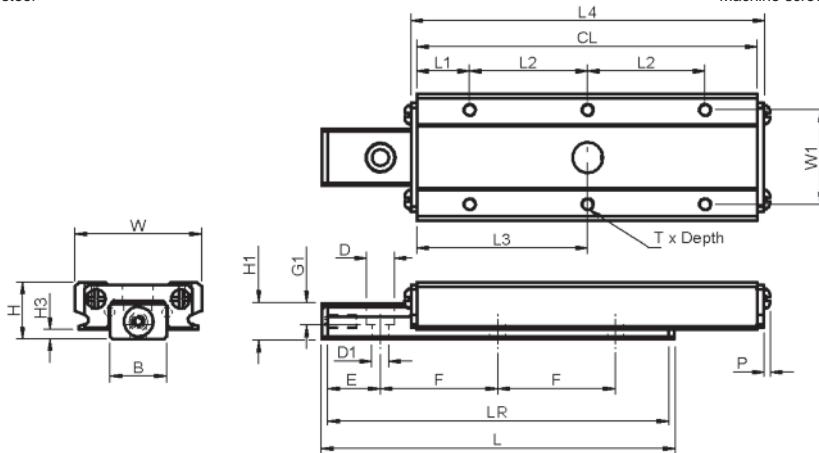

### Part number selection table

| Basic Part Number | Max Travel | Carriage Dimensions |    |      |     |      | Load Rating          |                     |                     |       |       |
|-------------------|------------|---------------------|----|------|-----|------|----------------------|---------------------|---------------------|-------|-------|
|                   |            | H                   | W  | CL   | L4  | L3   | Basic Dynamic Load N | Basic Static Load N | Static Moment Loads |       |       |
|                   |            |                     |    |      |     |      |                      |                     | To Nm               | Tx Nm | Ty Nm |
| <b>RST7M</b>      | 27         | 8                   | 17 | 28.0 | 30  | 14.0 | 910                  | 1,580               | 5.9                 | 3.4   | 3.4   |
|                   | 41         |                     |    | 43.0 | 45  | 21.5 | 1,220                | 2,500               | 9.1                 | 8.0   | 8.0   |
|                   | 55         |                     |    | 58.0 | 60  | 29.0 | 1,490                | 3,330               | 12.4                | 14.6  | 14.6  |
| <b>RST9M</b>      | 38         | 10                  | 20 | 38.0 | 40  | 19.0 | 1,590                | 2,773               | 13.1                | 6.8   | 6.8   |
|                   | 58         |                     |    | 58.0 | 60  | 29.0 | 2,080                | 4,170               | 19.7                | 16    | 16    |
|                   | 78         |                     |    | 78.0 | 80  | 39.0 | 2,520                | 5,547               | 26.2                | 29.2  | 29.2  |
| <b>RST12M</b>     | 44         | 13                  | 27 | 47.4 | 50  | 23.7 | 2,550                | 4,340               | 27.0                | 16    | 16    |
|                   | 69         |                     |    | 72.4 | 75  | 36.2 | 3,350                | 6,510               | 40.1                | 35.6  | 35.6  |
|                   | 94         |                     |    | 97.4 | 100 | 48.7 | 4,050                | 8,670               | 54.0                | 62.8  | 62.8  |

### Part number structure

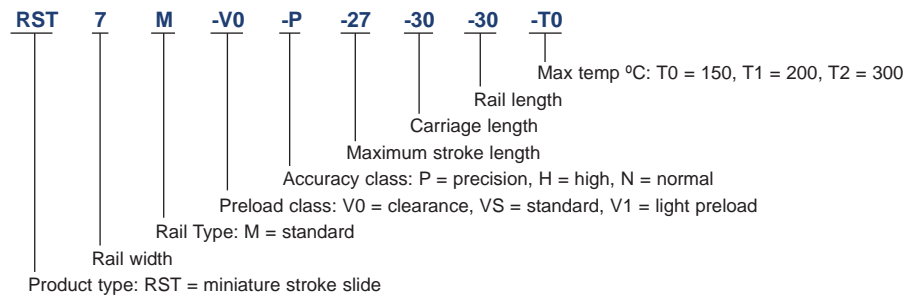



### Dimensions

| Basic Part Number | Rail Dimensions |     |                              |      |     |      |      | Carriage Dimensions |      |           |      |    |     |
|-------------------|-----------------|-----|------------------------------|------|-----|------|------|---------------------|------|-----------|------|----|-----|
|                   | B               | H1  | Mounting Hole<br>D x D1 x G1 | LR   | L   | E    | F    | H3                  | L1   | T x Depth | L2   | W1 | P   |
| RST7M             | 7               | 4.7 | 4.2 x 2.4 x 2.3              | 28   | 30  | 6.5  | 7.5  | 1.5                 | 6.5  | M2 x 2.5  | 7.5  | 12 | 1   |
|                   |                 |     |                              | 43   | 45  |      | 15.0 |                     |      |           |      |    |     |
|                   |                 |     |                              | 58   | 60  |      | 22.5 |                     |      |           |      |    |     |
| RST9M             | 9               | 5.5 | 6 x 3.5 x 3.5                | 38   | 40  | 9.0  | 10.0 | 2.2                 | 9.0  | M3 x 3.0  | 10.0 | 15 | 1.3 |
|                   |                 |     |                              | 58   | 60  |      | 20.0 |                     |      |           |      |    |     |
|                   |                 |     |                              | 78   | 80  |      | 30.0 |                     |      |           |      |    |     |
| RST12M            | 12              | 7.5 | 6 x 3.5 x 4.5                | 47.4 | 50  | 11.2 | 12.5 | 3.0                 | 11.2 | M3 x 3.5  | 12.5 | 20 | 1.3 |
|                   |                 |     |                              | 72.4 | 75  |      | 25.0 |                     |      |           |      |    |     |
|                   |                 |     |                              | 97.4 | 100 |      | 37.5 |                     |      |           |      |    |     |



### ? Technical support

- High load and high moment capacity
- High running accuracy and smoothness
- Easy mounting
- Operating temperature of up to 150°C as standard. Higher temperatures of up to 300°C available. Note that the higher temperature options will have a lower load capacity
- Life rating calculations - see [page T9-2](#)
- Lubrication details - see [page T9-2](#)
- Product overview - see [pages 9-2 to 9-3](#)



# Ball and Crossed Roller Slides

All dimensions in mm  
 General tolerances  $\pm 0.13$ mm  
 Material: See tables

**Associated Products**  
 Leadscrews: page 7-1  
 Hardware: page 13-1

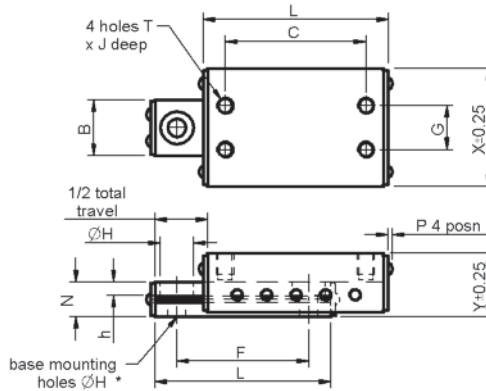

## Part number selection table

| Ballslide Series | Dimensions                     |                        |                       |                            |                       | Mounting Details         |                     |                             |               |         |
|------------------|--------------------------------|------------------------|-----------------------|----------------------------|-----------------------|--------------------------|---------------------|-----------------------------|---------------|---------|
|                  | Carriage Width X<br>$\pm 0.25$ | Height Y<br>$\pm 0.25$ | Screw P<br>$\pm 0.25$ | Base Width B<br>$\pm 0.25$ | Depth N<br>$\pm 0.25$ | Base                     |                     |                             | Carriage      |         |
|                  |                                |                        |                       |                            |                       | Hole Dia H<br>$\pm 0.25$ | Cbore $\varnothing$ | Cbore Depth h<br>$\pm 0.25$ | Thread Size T | Depth J |
| CA               | 9.7                            | 5.8                    | 1.3                   | 4.0                        | 3.4                   | M2*                      | --                  | --                          | M2            | 2.29    |
| DA & XDA         | 14.2                           | 8.0                    | 1.0                   | 6.4                        | 4.7                   | 2.2                      | 4.0                 | 2.2                         | M2            | 2.54    |
| EA & XEA         | 19.0                           | 10.4                   | 1.0                   | 9.5                        | 6.3                   | 3.5                      | 6.1                 | 3.4                         | M3            | 3.30    |
| MA               | 25.4                           | 12.7                   | 1.0                   | 12.7                       | 6.3                   | 3.5                      | 6.1                 | 3.4                         | M4            | 5.33    |
| NA & XNA         | 26.9                           | 13.4                   | 1.0                   | 12.7                       | 7.9                   | 4.6                      | 8.1                 | 4.4                         | M4            | 4.83    |
| SA1 & XSA1       | 38.0                           | 15.8                   | 1.3                   | 19.0                       | 8.6                   | 4.6                      | 8.1                 | 4.4                         | M4            | 6.35    |
| SA2 & XSA2       | 44.0                           | 19.0                   | 2.0                   | 22.2                       | 10.2                  | 4.6                      | 8.1                 | 4.4                         | M4            | 8.13    |
| SA3 & XSA3       | 66.5                           | 25.4                   | 2.0                   | 38.1                       | 15.9                  | 5.8                      | 10.0                | 5.3                         | M5            | 8.38    |

L, C & F dimensions, see part number on page 9-15

\* For CA series slides, H holes are threaded and not counterbored.

## Specifications

| Feature                  | Ball Slide   | Crossed Roller Slide<br>(higher load capacity) |
|--------------------------|--|--|
| Straight line accuracy   | 0.0005 mm/mm   | 0.0001 mm/mm                                   |
| Positional repeatability | 0.005 mm   | 0.003 mm                                       |
| Coefficient of friction  | 0.003 typical  | 0.003 typical                                  |
| Construction             | Aluminium carriage and base<br>Hardened steel rods and balls/rollers<br>Steel end caps | Stainless steel end caps                       |
| Finish: Carriage         | Clear anodised   | Black anodised                                 |
| Base                     | Black anodised   | Black anodised                                 |

# Ball and Crossed Roller Slides



Drawing dimension and mounting table

| Part Number  |                | Total Travel | Slide Length<br>L<br>±0.25 | Hole Centres<br>C<br>±0.25 | Hole Centres<br>F<br>±0.25 | Hole Centres<br>G<br>±0.25 | Dynamic Load Capacity (N) |                |
|--------------|----------------|--------------|----------------------------|----------------------------|----------------------------|----------------------------|---------------------------|----------------|
| Ball Bearing | Crossed Roller |              |                            |                            |                            |                            | Ball Bearing              | Crossed Roller |
| CA-1         | --             | 13           | 19                         | 13                         | 10                         |                            | 6.67                      | --             |
| CA-2         | --             | 25           | 32                         | 26                         | 20                         | 4                          | 6.67                      | --             |
| CA-3         | --             | 38           | 44                         | 37                         | 30                         |                            | 6.67                      | --             |
| DA-1         | XDA-1          | 13           | 27                         | 15                         | 19                         |                            | 19.62                     | 137.34         |
| DA-2         | XDA-2          | 25           | 52                         | 41                         | 35                         |                            | 39.24                     | 245.25         |
| DA-3         | XDA-3          | 50           | 78                         | 66                         | 60                         | 6                          | 49.05                     | 294.30         |
| DA-4         | --             | 75           | 103                        | 92                         | 86                         |                            | 58.86                     | --             |
| DA-5         | --             | 100          | 128                        | 117                        | 89                         |                            | 78.48                     | --             |
| DA-6         | --             | 127          | 154                        | 142                        | 114                        |                            | 78.48                     | --             |
| EA-1         | XEA-1          | 13           | 27                         | 15                         | 19                         |                            | 39.24                     | 215.82         |
| EA-2         | XEA-2          | 25           | 52                         | 41                         | 35                         |                            | 49.05                     | 343.35         |
| EA-3         | XEA-3          | 50           | 78                         | 66                         | 60                         | 9                          | 49.05                     | 412.02         |
| EA-4         | --             | 75           | 103                        | 92                         | 86                         |                            | 58.86                     | --             |
| EA-5         | --             | 100          | 128                        | 117                        | 89                         |                            | 68.67                     | --             |
| EA-6         | --             | 127          | 154                        | 142                        | 114                        |                            | 78.48                     | --             |
| MA-1         | --             | 13           | 40                         | 32                         | 32                         |                            | 49.05                     | --             |
| MA-2         | --             | 25           | 65                         | 57                         | 57                         | 10                         | 49.05                     | --             |
| MA-3         | --             | 50           | 90                         | 82                         | 82                         |                            | 68.67                     | --             |
| NA-1         | --             | 19           | 40                         | 32                         | 28                         |                            | 68.67                     | --             |
| NA-2         | XNA-2          | 38           | 65                         | 57                         | 54                         |                            | 78.48                     | 588.60         |
| NA-3         | XNA-3          | 50           | 90                         | 82                         | 79                         |                            | 88.29                     | 981.00         |
| NA-4         | XNA-4          | 75           | 116                        | 102                        | 82                         | 10                         | 107.91                    | 1177.21        |
| NA-6         | --             | 100          | 152                        | 140                        | 102                        |                            | 137.34                    | --             |
| NA-8         | --             | 150          | 203                        | 190                        | 127                        |                            | 156.96                    | --             |
| NA-10        | --             | 200          | 254                        | 240                        | 178                        |                            | 176.58                    | --             |
| SA1-1        | XSA1-1         | 25           | 51                         | 35                         | 37                         |                            | 68.67                     | 578.79         |
| SA1-2        | XSA1-2         | 50           | 76                         | 60                         | 60                         |                            | 88.29                     | 774.99         |
| SA1-4        | XSA1-4         | 100          | 152                        | 136                        | 100                        | 16                         | 156.96                    | 1363.59        |
| SA1-6        | --             | 150          | 203                        | 186                        | 128                        |                            | 196.20                    | --             |
| SA1-8        | --             | 200          | 254                        | 238                        | 178                        |                            | 245.25                    | --             |
| SA2-1        | XSA2-1         | 25           | 51                         | 35                         | 38                         |                            | 88.29                     | 578.79         |
| SA2-2        | XSA2-2         | 50           | 83                         | 65                         | 65                         |                            | 186.39                    | 774.99         |
| SA2-3        | XSA2-3         | 75           | 102                        | 85                         | 85                         | 20                         | 235.44                    | 774.99         |
| SA2-4        | XSA2-4         | 100          | 152                        | 140                        | 100                        |                            | 264.87                    | 1363.59        |
| SA2-8        | --             | 200          | 254                        | 240                        | 178                        |                            | 402.21                    | --             |
| SA3-1.5      | XSA3-1.5       | 38           | 67                         | 42                         | 42                         |                            | 156.96                    | 1167.39        |
| SA3-2        | XSA3-2         | 50           | 102                        | 75                         | 75                         |                            | 274.68                    | 1549.98        |
| SA3-4        | XSA3-4         | 100          | 152                        | 125                        | 125                        |                            | 529.74                    | 1942.38        |
| SA3-6        | XSA3-6         | 150          | 229                        | 75 x2                      | 178                        | 35                         | 667.08                    | 3109.77        |
| SA3-9        | --             | 228          | 305                        | 75 x3                      | 254                        |                            | 824.04                    | --             |
| SA3-12       | --             | 304          | 381                        | 75 x4                      | 330                        |                            | 912.33                    | --             |

Linear Guides  
and Slides



# Rack Driven Ballslides

All dimensions in mm  
General tolerances  $\pm 0.13$  mm

**Associated Products**  
Rack pinions: page 6-10  
Hardware: page 13-1

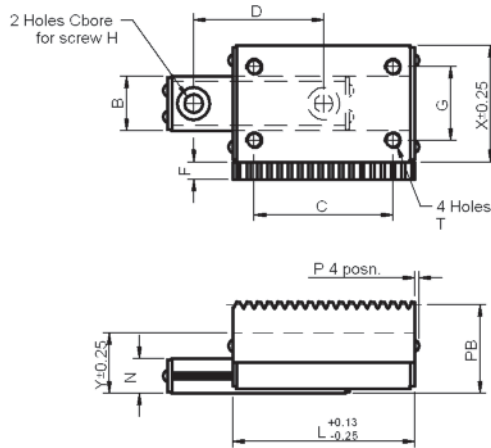

## Drawing dimension and mounting table

| Ballslide Series | Dimensions   |           |                  |          |         |              |         | Mounting Details |               |
|------------------|--------------|-----------|------------------|----------|---------|--------------|---------|------------------|---------------|
|                  | Rack         |           | Slide            |          |         |              |         | Base             | Carriage      |
|                  | Face Width F | Height PB | Carriage Width X | Height Y | Screw P | Base Width B | Depth N | Screw H          | Thread Size T |
| <b>RDA</b>       | 2.50         | 11.629    | 14.22            | 8.13     | 1.0     | 6.35         | 4.75    | M2               | M2            |
| <b>REA</b>       | 3.75         | 11.500    | 19.05            | 10.41    | 1.0     | 9.53         | 6.35    | M3               | M3            |
| <b>RNA</b>       | 3.75         | 14.500    | 26.92            | 13.46    | 1.0     | 12.70        | 7.92    | M4               | M4            |
| <b>RSA2</b>      | 7.56         | 20.690    | 44.45            | 19.05    | 2.0     | 22.23        | 10.16   | M4               | M4            |

L, C & D dimension, see part number on page 9-17

## Slide specification

|                          |  |
|--------------------------|--|
| Straight line accuracy   | 0.0005 mm per mm   |
| Positional repeatability | 0.005 mm   |
| Coefficient of friction  | 0.003 typical  |
| Construction             | Aluminium carriage and base<br>Hardened steel rods and balls<br>Steel end caps |
| Finish: Carriage         | Clear anodised standard (black finish available)                               |
| Base                     |  |



# Rack Driven Ballslides



## Part number selection table

| Part Number | Ballslide Travel<br>+1.5/-0.0 | Ballslide Length<br>L | Hole Centres<br>C | Hole Centres<br>D | Hole Centres<br>G | Ballslide Load Capacity<br>N |
|-------------|-------------------------------|-----------------------|-------------------|-------------------|-------------------|------------------------------|
| RDA-1       | 12.7                          | 26.92                 | 15                | 19                |                   | 17.8                         |
| RDA-3       | 50.8                          | 77.72                 | 66                | 60                | 6.0               | 53.4                         |
| RDA-6       | 127.0                         | 153.92                | 142               | 114               |                   | 80.1                         |
| REA-1       | 12.7                          | 26.92                 | 15                | 19                |                   | 35.6                         |
| REA-3       | 50.8                          | 77.72                 | 66                | 60                | 9.0               | 53.4                         |
| REA-6       | 127.0                         | 153.92                | 142               | 114               |                   | 80.1                         |
| RNA-3       | 50.8                          | 90.42                 | 82                | 79                |                   | 89.0                         |
| RNA-6       | 101.6                         | 152.40                | 140               | 102               | 10.0              | 133.5                        |
| RNA-10      | 203.2                         | 254.00                | 240               | 178               |                   | 178.0                        |
| RSA2-2      | 50.8                          | 82.55                 | 65                | 65                |                   | 186.9                        |
| RSA2-4      | 101.6                         | 152.40                | 140               | 100               | 20.0              | 267.1                        |
| RSA2-8      | 203.2                         | 254.00                | 240               | 178               |                   | 400.6                        |

## Rack specifications

| Ballslide Series | Rack Circular Pitch | Material        | Hardness  | Cumulative Pitch Error per 300mm |
|------------------|---------------------|-----------------|-----------|----------------------------------|
| RDA              | 1.0                 | Stainless steel | 35-45 HRc | 0.008mm                          |
| REA              |                     |                 |           |                                  |
| RNA              |                     |                 |           |                                  |
| RSA2             | 2.5                 |                 |           |                                  |

Linear Guides  
and Slides

### **i** Product options

- Product overview - see pages 9-2 to 9-3
- Imperial racks



### **?** Technical support

- Technical information - see page T9-1





# Section Contents

|                                  |            |
|----------------------------------|------------|
| Timing Belts 2.5mm Pitch .....   | Page 10-2  |
| Timing Pulleys 2.5mm Pitch ..... | Page 10-3  |
| Timing Belts 5mm Pitch .....     | Page 10-4  |
| Timing Pulleys 5mm Pitch .....   | Page 10-5  |
| Technical Information.....       | Page T10-1 |



All dimensions in mm  
Material: High tensile steel  
reinforced polyurethane

**Associated Products**  
Timing pulleys: page 10-3

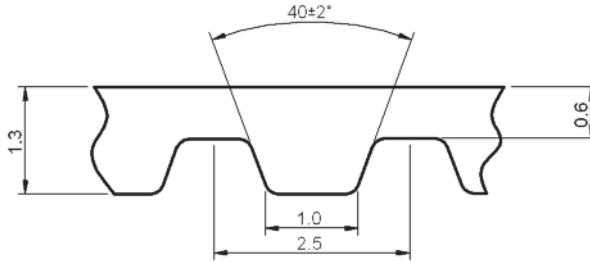

### Part number selection table

| Example Part No:- |                    | <b>TXM25 F6- 168</b>          |           |                   |           |
|-------------------|--------------------|-------------------------------|-----------|-------------------|-----------|
| Basic Part Number | Belt Width         | Standard Lengths <sup>#</sup> |           |                   |           |
|                   |                    | Number of Pitches             | Length mm | Number of Pitches | Length mm |
| <b>TXM25</b>      | 6 mm<br><b>F6-</b> | <b>48</b>                     | 120.0     | <b>127</b>        | 317.5     |
|                   |                    | <b>58</b>                     | 145.0     | <b>132</b>        | 330.0     |
|                   |                    | <b>64</b>                     | 160.0     | <b>152</b>        | 380.0     |
|                   |                    | <b>71</b>                     | 177.5     | <b>168</b>        | 420.0     |
|                   |                    | <b>72</b>                     | 180.0     | <b>192</b>        | 480.0     |
|                   |                    | <b>73</b>                     | 182.5     | <b>200</b>        | 500.0     |
|                   |                    | <b>80</b>                     | 200.0     | <b>240</b>        | 600.0     |
|                   |                    | <b>92</b>                     | 230.0     | <b>248</b>        | 620.0     |
|                   |                    | <b>98</b>                     | 245.0     | <b>260</b>        | 650.0     |
|                   |                    | <b>106</b>                    | 265.0     | <b>312</b>        | 780.0     |
|                   |                    | <b>114</b>                    | 285.0     | <b>380</b>        | 950.0     |
|                   |                    | <b>116</b>                    | 290.0     |                   |           |

<sup>#</sup> The belt thickness may differ if a non-standard length is ordered

### **i** Features and options

- Temperature range: -10°C to +80°C
- Maximum allowable peripheral load:  
6 mm wide = 65 N
- Maximum peripheral speed: 80 m/s
- Special polyurethanes available
- Double-sided belt available
- Alternative lengths available<sup>#</sup>
- Alternative colours available
- Kevlar tension members available
- Anti-static belts available

### **?** Technical support

- Technical information - see page T10-1
- Design guidelines - see page T10-2



**Associated Products**  
 Intelligent motors: page 2-2  
 Shafts: page 11-2  
 Timing belts: page 10-2

All dimensions in mm  
 Materials: Aluminium alloy  
 pulley with zinc plated  
 steel flanges

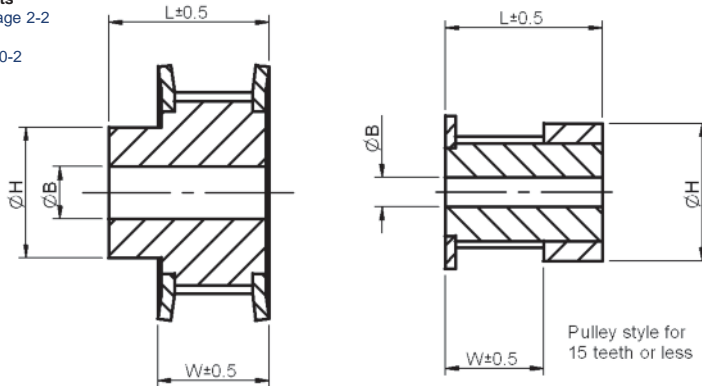

Pulley style for 15 teeth or less

### Part number selection table

When belt width = 6, W=10 & L=16

| Example Part No:- <b>TPMP25 F6- 60</b> |             |              |                |              |                      |
|--|-------------|--------------|----------------|--------------|----------------------|
| Basic Part Number                      | Belt Width  | No. of Teeth | Pitch Diameter | Bore ØB (H8) | Hub Diameter ØH ±1.0 |
| TPMP25                                 | 6 mm<br>F6- | 12           | 9.55           | 3            | 13                   |
|  |             | 14           | 11.14          |              | 15                   |
|  |             | 15           | 11.94          |              | 15                   |
|  |             | 18           | 14.32          | 4            | 10                   |
|  |             | 19           | 15.12          |              | 10                   |
|  |             | 20           | 15.92          |              | 11                   |
|  |             | 24           | 19.10          |              | 12                   |
|  |             | 25           | 19.89          | 6            | 13                   |
|  |             | 30           | 23.87          |              | 16                   |
|  |             | 32           | 25.46          |              | 16                   |
|  |             | 36           | 28.65          | 8            | 20                   |
|  |             | 40           | 31.83          |              | 22                   |
|  |             | 48*          | 38.20          |              | 26                   |
|  |             | 60*          | 47.75          |              | 34                   |

\*Pulleys with 48 and 60 teeth are unflanged

### **i** Features and options

- Zero-backlash pulleys
- Other numbers of teeth available
- 0, 1 or 2 flanges available
- Tapped holes in hubs available
- Alternative bore diameters available
- Alternative mountings available
- Keyed bores available

### **?** Technical support

- Technical information - see page T10-1
- Design guidelines - see page T10-2

Belts and Pulleys



All dimensions in mm  
Material: High tensile steel  
reinforced polyurethane

**Associated Products**  
Timing pulleys: page 10-5

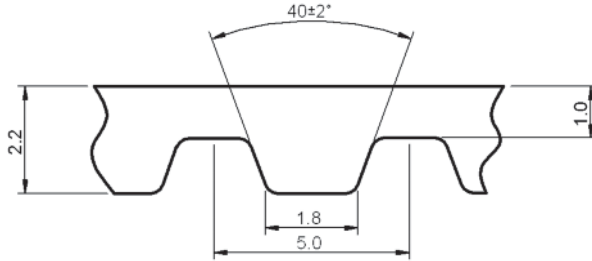

### Part number selection table

| Example Part No:- |                     | <b>TXM50 F10- 168</b>         |           |                   |           |                   |           |
|-------------------|---------------------|-------------------------------|-----------|-------------------|-----------|-------------------|-----------|
| Basic Part Number | Belt Width          | Standard Lengths <sup>#</sup> |           |                   |           |                   |           |
|                   |                     | Number of Pitches             | Length mm | Number of Pitches | Length mm | Number of Pitches | Length mm |
| TXM50             | 10 mm<br>F10-       | 20                            | 100       | 66                | 330       | 126               | 630       |
|                   |                     | 30                            | 150       | 68                | 340       | 138               | 690       |
|                   |                     | 33                            | 165       | 73                | 365       | 140               | 700       |
|                   |                     | 36                            | 180       | 80                | 400       | 145               | 725       |
|                   |                     | 37                            | 185       | 82                | 410       | 150               | 750       |
|                   |                     | 40                            | 200       | 84                | 420       | 156               | 780       |
|                   |                     | 42                            | 210       | 91                | 455       | 163               | 815       |
|                   |                     | 43                            | 215       | 96                | 480       | 168               | 840       |
|                   | or<br>16 mm<br>F16- | 45                            | 225       | 100               | 500       | 180               | 900       |
|                   |                     | 49                            | 245       | 102               | 510       | 185               | 925       |
|                   |                     | 50                            | 250       | 105               | 525       | 188               | 940       |
|                   |                     | 52                            | 260       | 110               | 550       | 198               | 990       |
|                   |                     | 54                            | 270       | 115               | 575       | 215               | 1,075     |
|                   |                     | 56                            | 280       | 122               | 610       | 243               | 1,215     |
|                   |                     | 59                            | 295       | 124               | 620       | 276               | 1,380     |

<sup>#</sup> The belt thickness may differ if a non-standard length is ordered

### **i** Features and options

- Temperature range: -10°C to +80°C
- Maximum allowable peripheral load:  
10 mm wide = 330 N, 16 mm wide = 570 N
- Maximum peripheral speed: 80 m/s
- Special polyurethanes available
- Double-sided belt available
- Alternative lengths available<sup>#</sup>
- Alternative colours available
- Kevlar tension members available
- Anti-static belts available

### **?** Technical support

- Technical information - see page T10-1
- Design guidelines - see page T10-2



**Associated Products**  
 Intelligent motors: page 2-2  
 Shafts: page 11-2  
 Timing belts: page 10-4

All dimensions in mm  
 Materials: Aluminium alloy  
 pulley with zinc plated  
 steel flanges

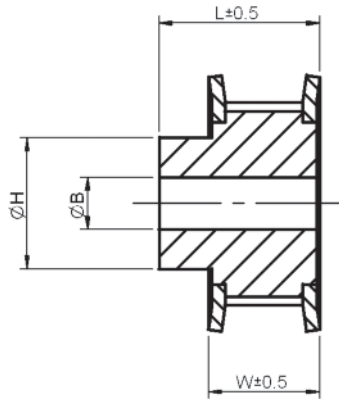

### Part number selection table

When belt width = 10, W=15 & L=21  
 When belt width = 16, W=21 & L=27

| Example Part No:- <b>TPMP50 F10- 60</b> |                      |              |                |              |                      |
|---|----------------------|--------------|----------------|--------------|----------------------|
| Basic Part Number                       | Belt Width           | No. of Teeth | Pitch Diameter | Bore ØB (H8) | Hub Diameter ØH ±1.0 |
| <b>TPMP50</b>                           | 10 mm<br><b>F10-</b> | <b>10</b>    | 15.92          | 4            | 8                    |
|   |                      | <b>12</b>    | 19.10          |              | 11                   |
|   |                      | <b>14</b>    | 22.28          | 6            | 13                   |
|   |                      | <b>15</b>    | 23.87          |              | 16                   |
|   |                      | <b>16</b>    | 25.46          |              | 18                   |
|   |                      | <b>18</b>    | 28.65          |              | 20                   |
|   |                      | <b>19</b>    | 30.24          |              | 22                   |
|   |                      | <b>20</b>    | 31.83          |              | 23                   |
|   |                      | <b>24</b>    | 38.20          |              | 26                   |
|   |                      | <b>25</b>    | 39.79          |              | 26                   |
|   | <b>27</b>            | 42.97        | 30             |              |                      |
|   | 16 mm<br><b>F16-</b> | <b>30</b>    | 47.75          | 8            | 34                   |
|   |                      | <b>32</b>    | 50.93          |              | 38                   |
|   |                      | <b>36</b>    | 57.30          |              | 38                   |
|   |                      | <b>40</b>    | 63.66          |              | 40                   |
|   |                      | <b>48*</b>   | 76.39          |              | 50                   |
|   |                      | <b>60*</b>   | 95.49          |              | 65                   |

\*Pulleys with 48 and 60 teeth are unflanged

### **i** Features and options

- Zero-backlash pulleys
- Other numbers of teeth available
- 0, 1 or 2 flanges available
- Tapped holes in hubs available
- Alternative bore diameters available
- Alternative mountings available
- Keyed bores available

### **?** Technical support

- Technical information - see page T10-1
- Design guidelines - see page T10-2

Belts and Pulleys





# Section Contents

- Shafts - Ground Stock .....Page 11-2
- Shaft Retaining Collars .....Page 11-3
- Gear Clamps .....Page 11-4
- Gear Clamps - Low Inertia .....Page 11-5
- Gear and Dial Hubs - Pin Type .....Page 11-6
- Gear and Dial Hubs- Clamp Type .....Page 11-7



# Shafts - Ground Stock

All dimensions in mm  
 General tolerances  $\pm 0.13$  mm  
 Material: Stainless steel 303 series  
 Straightness: 0.0003 mm/mm  
 Surface finish: 0.25  $\mu$ m

**Associated Products**  
 Shaft collars: page 11-3  
 Bearings: page 12-2  
 Couplings: page 8-1

## Cut to Length

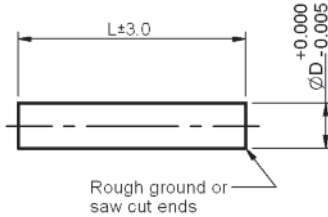

## Machined to Length

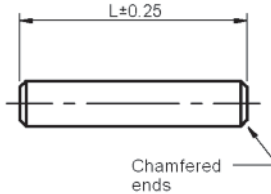

### Part number selection table - Cut to length

| Basic Part Number | Diameter $\varnothing D$ | Length L | Basic Part Number | Diameter $\varnothing D$ | Length L |
|-------------------|--------------------------|----------|-------------------|--------------------------|----------|
| SM1-3-            | 2.993                    | 600      | SM1-6A-           | 6.000                    | 600      |
| SM1-3A-           | 3.000                    |          | SM1-8-            | 7.993                    |          |
| SM1-4-            | 3.993                    |          | SM1-8A-           | 8.000                    |          |
| SM1-4A-           | 4.000                    |          | SM1-10-           | 9.993                    | 1,000    |
| SM1-5A-           | 5.000                    |          | SM1-10A-          | 10.000                   |          |
| SM1-6-            | 5.993                    |          | SM1-12-           | 11.993                   |          |
|                   |                          |          | SM1-12A-          | 12.000                   |          |

To complete the part number add length details to part number eg **SM1-8-600**

### Part number selection table - Machined to length

| Basic Part Number                                    | Diameter $\varnothing D$                            | Available Lengths |             |          |             |          |             |
|--|---|-------------------|-------------|----------|-------------|----------|-------------|
|  |   | Length L          | Length Code | Length L | Length Code | Length L | Length Code |
| SM2-3<br>SM2-4<br>SM2-6<br>SM2-8<br>SM2-10<br>SM2-12 | 2.993<br>3.993<br>5.993<br>7.993<br>9.993<br>11.993 | 25                | -25         | 70       | -70         | 115      | -115        |
|  |   | 30                | -30         | 75       | -75         | 120      | -120        |
|  |   | 35                | -35         | 80       | -80         | 125      | -125        |
|  |   | 40                | -40         | 85       | -85         | 150      | -150        |
|  |   | 45                | -45         | 90       | -90         | 175      | -175        |
|  |   | 50                | -50         | 95       | -95         | 200      | -200        |
|  |   | 55                | -55         | 100      | -100        | 225      | -225        |
|  |   | 60                | -60         | 105      | -105        | 250      | -250        |
|  |   | 65                | -65         | 110      | -110        | 275      | -275        |

To complete the part number add length details to part number eg **SM2-8-250**

### **i** Product options

- Standard shaft end modifications, similar to those on leadscrews, are available - see page 7-27
- Imperial sizes available

# Shaft Retaining Collars



## Associated Products

Hubless gears: page 4-52  
 Hubless brass gears: page 4-78  
 Shafts: page 11-2  
 Bearings: page 12-2

All dimensions in mm  
 General tolerances  $\pm 0.13$  mm  
 Material: Stainless steel  
 303S31 or 303S21

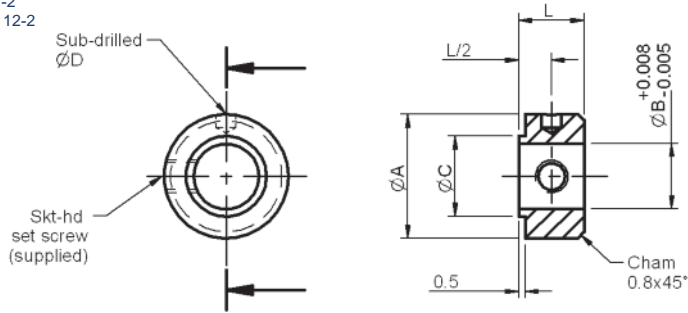

## Part number selection table

| Part Number   | Bore ØB | Length L | Outer Dia ØA | Shoulder Dia ØC | Sub-drill ØD | Set Screw Supplied |
|---------------|---------|----------|--------------|-----------------|--------------|--------------------|
| <b>CSM-2</b>  | 2.0     | 5.0      | 7.0          | 3.0             | 0.75         | SS-M1.6-2          |
| <b>CSM-3</b>  | 3.0     | 5.0      | 8.0          | 4.1             | 0.75         | SS-M2-2            |
| <b>CSM-4</b>  | 4.0     | 5.0      | 8.0          | 5.3             | 1.00         | SS-M2-2            |
| <b>CSM-5</b>  | 5.0     | 6.0      | 10.0         | 6.7             | 1.20         | SS-M3-3            |
| <b>CSM-6</b>  | 6.0     | 6.0      | 10.0         | 7.9             | 1.50         | SS-M3-3            |
| <b>CSM-8</b>  | 8.0     | 6.0      | 12.0         | 10.2            | 1.80         | SS-M4-4            |
| <b>CSM-10</b> | 10.0    | 10.0     | 19.0         | 12.3            | 3.00         | SS-M5-4            |
| <b>CSM-12</b> | 12.0    | 11.0     | 25.0         | 15.2            | 3.00         | SS-M6-6            |

## Product options

- Imperial sizes available

Gear Clamps & Accessories



# Gear Clamps

All dimensions in mm  
 General tolerances  $\pm 0.13$  mm  
 Material: Stainless steel, 303S21

**Associated Products**  
 Clamp hub gears: from page 4-36  
 Anti-backlash gears: from page 4-22

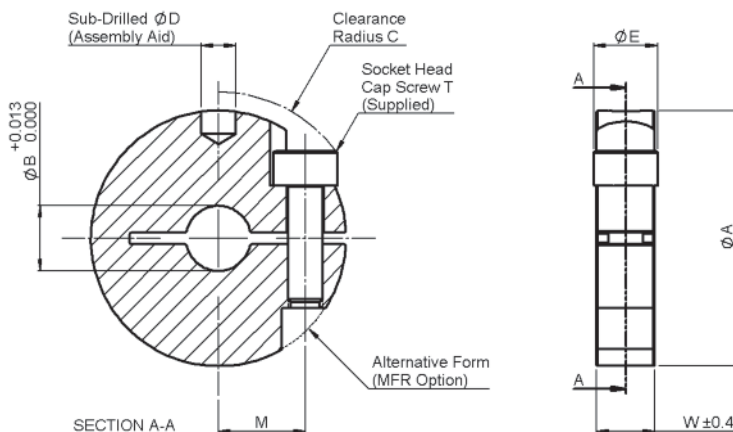

## Part number selection table

| Part Number | To Suit Gear of Bore Dia | Bore $\phi B$ | Outer Dia $\phi A$ | Width W | Head Dia $\phi E$ (max) | Clearance Radius C | Screw Supplied T | Screw Offset M | Sub-drill $\phi D$ |
|-------------|--------------------------|---------------|--------------------|---------|-------------------------|--------------------|------------------|----------------|--------------------|
| CGM1-2      | 2                        | 3.6           | 16.0               | 4.0     | 3.8*                    | 8.7                | M2               | 5.3            | 1.5                |
| CGM1-3      | 3                        | 4.6           |                    |         |                         |                    |                  |                |                    |
| CGM1-4      | 4                        | 5.6           |                    |         |                         |                    |                  |                |                    |
| CGM1-5      | 5                        | 6.6           | 22.0               | 5.0     | 5.5                     | 12.8               | M3               | 7.5            | 3.0                |
| CGM1-6      | 6                        | 7.6           |                    |         |                         |                    |                  |                |                    |
| CGM1-8      | 8                        | 9.6           | 29.0               | 6.0     | 7.0                     | 17.1               | M4               | 9.5            | 4.0                |
| CGM1-10     | 10                       | 11.6          |                    |         |                         |                    |                  |                |                    |
| CGM1-12     | 12                       | 13.6          |                    |         |                         |                    |                  |                |                    |

\* Socket head on these components is narrower than the clamp

## **i** Product options

- Imperial sizes available



# Gear Clamps - Low Inertia



## Associated Products

Clamp hub gears: from page 4-36  
 Anti-backlash gears: from page 4-22  
 Anti-backlash pinions: page 4-7

All dimensions in mm  
 General tolerances  $\pm 0.13$  mm  
 Material: Aluminium alloy, EN AW-2014-T6511 or L168  
 Finish: Chromic acid anodise to DEF STAN 03-24

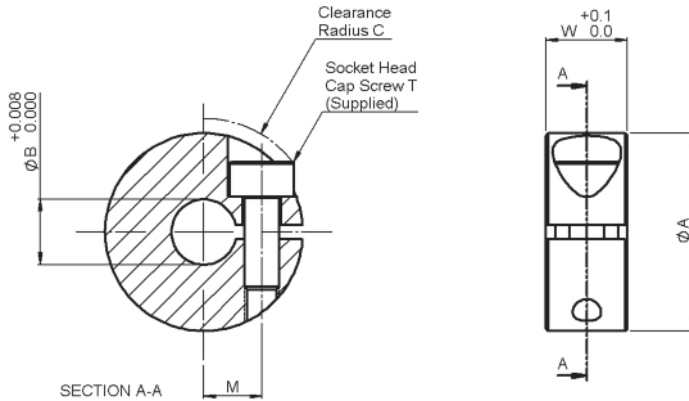

## Part number selection table

| Part Number     | To Suit Gear of Bore Dia | Bore ØB | Outer Dia ØA | Width W | Clearance Radius C | Screw Supplied T | Screw Offset M |
|-----------------|--------------------------|---------|--------------|---------|--------------------|------------------|----------------|
| <b>CGAM-2A</b>  | 2                        | 3.6     | 12.0         | 5.0     | 7.2                | M2               | 3.5            |
| <b>CGAM-3A</b>  | 3                        | 4.6     | 13.0         |         | 7.8                |                  | 4.0            |
| <b>CGAM-4A</b>  | 4                        | 5.6     | 17.0         | 7.0     | 10.0               | M3               | 5.0            |
| <b>CGAM-5A</b>  | 5                        | 6.6     | 18.0         |         | 10.6               |                  | 5.5            |
| <b>CGAM-6A</b>  | 6                        | 7.6     | 19.0         |         | 11.3               |                  | 6.2            |
| <b>CGAM-8A</b>  | 8                        | 9.6     | 24.0         | 9.0     | 13.8               | M4               | 7.5            |
| <b>CGAM-10A</b> | 10                       | 11.6    | 26.0         |         | 14.8               |                  | 8.5            |
| <b>CGAM-12A</b> | 12                       | 13.6    | 28.0         |         | 16.2               |                  | 9.8            |

## Product options

- Imperial sizes available

Gear Clamps & Accessories



# Gear and Dial Hubs Pin Type

All dimensions in mm  
General tolerances  $\pm 0.13$  mm  
Material: Stainless steel

**Associated Products**  
Hubless gears: page 4-52  
Hubless brass gears: page 4-78

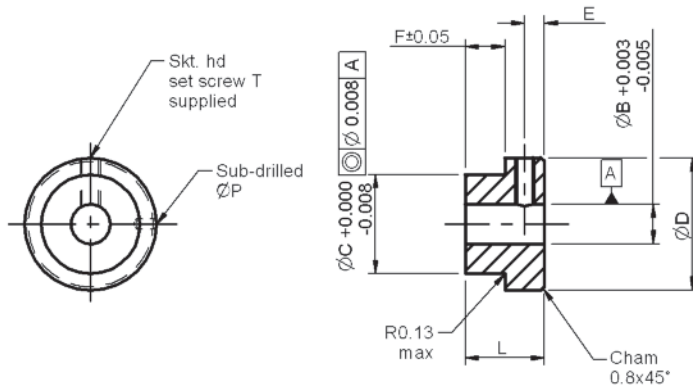

## Part number selection table - Dial hubs

| Part Number | Bore<br>$\varnothing B$ | Face<br>F | Length<br>L | Outer Diameter<br>$\varnothing D$ | Mount Diameter<br>$\varnothing C$ | Sub-drill<br>$\varnothing P$ | Distance<br>E | Set Screw Supplied<br>T |
|-------------|-------------------------|-----------|-------------|-----------------------------------|-----------------------------------|------------------------------|---------------|-------------------------|
| PHMD-1      | 3.0                     |           | 7.2         |                                   |                                   | 0.75                         |               | SS-M2-2                 |
| PHMD-3      | 4.0                     | 1.57      | 7.2         | 11.0                              | 9.52                              | 1.00                         | 2.8           | SS-M2-2                 |
| PHMD-5      | 6.0                     |           | 8.0         |                                   |                                   | 1.50                         |               | SS-M3-3                 |

## Part number selection table - Gear hubs

| Part Number | Bore<br>$\varnothing B$ | Face<br>F | Length<br>L | Outer Diameter<br>$\varnothing D$ | Mount Diameter<br>$\varnothing C$ | Sub-drill<br>$\varnothing P$ | Distance<br>E | Set Screw Supplied<br>T |
|-------------|-------------------------|-----------|-------------|-----------------------------------|-----------------------------------|------------------------------|---------------|-------------------------|
| PHM1-1      | 3.0                     | 3.0       | 9.0         | 12.0                              | 10.0                              | 0.75                         | 3.0           | SS-M2-2                 |
| PHM1-2      |                         | 6.0       | 12.0        |                                   |                                   |                              |               |                         |
| PHM1-3      | 4.0                     | 3.0       | 9.0         | 12.0                              | 10.0                              | 1.00                         | 3.0           | SS-M2-2                 |
| PHM1-4      |                         | 6.0       | 12.0        |                                   |                                   |                              |               |                         |
| PHM1-5      | 6.0                     | 3.0       | 9.0         | 20.0                              | 15.0                              | 1.50                         | 3.0           | SS-M3-3                 |
| PHM1-6      |                         | 6.0       | 12.0        |                                   |                                   |                              |               |                         |
| PHM1-7      | 8.0                     | 3.0       | 12.0        | 20.0                              | 15.0                              | 1.80                         | 4.5           | SS-M4-4                 |
| PHM1-8      |                         | 6.0       | 15.0        |                                   |                                   |                              |               |                         |
| PHM1-9      | 10.0                    | 6.0       | 18.0        | 30.0                              | 25.0                              | 3.00                         | 6.0           | SS-M5-5                 |
| PHM1-10     |                         | 8.0       | 20.0        |                                   |                                   |                              |               |                         |
| PHM1-11     |                         | 10.0      | 22.0        |                                   |                                   |                              |               |                         |

### **i** Features and options

- Gears, sprockets or dials assembled on request
- Imperial bores available
- Special hubs for Delrin gears

### **?** Technical support

- Recommended assembly procedure: Notch and stake in 4 equi-spaced positions and/or use adhesive (Loctite grade 326)

# Gear and Dial Hubs Clamp Type



**Associated Products**  
 Hubless gears: page 4-52  
 Hubless brass gears: page 4-78

All dimensions in mm  
 General tolerances  $\pm 0.13$  mm  
 Material: Stainless steel

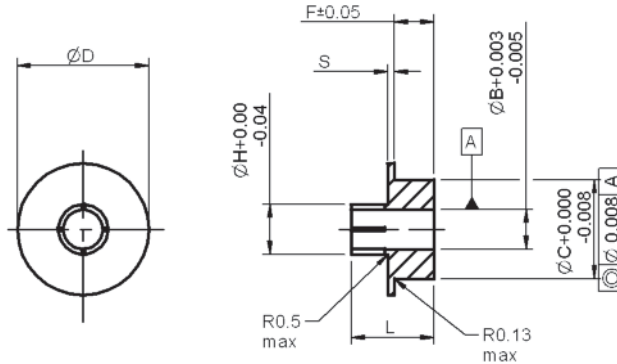

## Part number selection table - Dial hubs

| Part Number | Bore<br>$\varnothing B$ | Face<br>F | Length<br>L | Outer Diameter<br>$\varnothing D$ | Mount Diameter<br>$\varnothing C$ | Hub Diameter<br>$\varnothing H$ | Shoulder<br>S | To Suit Clamp |
|-------------|-------------------------|-----------|-------------|-----------------------------------|-----------------------------------|---------------------------------|---------------|---------------|
| CHMD-1      | 3.0                     | 1.57      | 8.7         | 12.0                              | 9.52                              | 4.6                             | 1.0           | CGM1-3        |
| CHMD-3      | 4.0                     |           |             | 12.0                              |                                   | 5.6                             |               | CGM1-4        |
| CHMD-5      | 6.0                     |           |             | 20.0                              |                                   | 7.6                             |               | CGM1-6        |

## Part number selection table - Gear hubs

| Part Number | Bore<br>$\varnothing B$ | Face<br>F | Length<br>L | Outer Diameter<br>$\varnothing D$ | Mount Diameter<br>$\varnothing C$ | Hub Diameter<br>$\varnothing H$ | Shoulder<br>S | To Suit Clamp |
|-------------|-------------------------|-----------|-------------|-----------------------------------|-----------------------------------|---------------------------------|---------------|---------------|
| CHM1-1      | 3.0                     | 3.0       | 8.5         | 12.0                              | 10.0                              | 4.6                             | 1.0           | CGM1-3        |
| CHM1-2      |                         | 6.0       | 11.5        |                                   |                                   |                                 |               |               |
| CHM1-3      | 4.0                     | 3.0       | 9.5         | 12.0                              | 10.0                              | 5.6                             | 1.0           | CGM1-4        |
| CHM1-4      |                         | 6.0       | 12.5        |                                   |                                   |                                 |               |               |
| CHM1-5      | 6.0                     | 3.0       | 9.5         | 20.0                              | 15.0                              | 7.6                             | 1.0           | CGM1-6        |
| CHM1-6      |                         | 6.0       | 12.5        |                                   |                                   |                                 |               |               |
| CHM1-7      | 8.0                     | 3.0       | 11.0        | 20.0                              | 15.0                              | 9.6                             | 1.5           | CGM1-8        |
| CHM1-8      |                         | 6.0       | 14.0        |                                   |                                   |                                 |               |               |
| CHM1-9      | 10.0                    | 6.0       | 14.0        | 30.0                              | 25.0                              | 11.6                            | 1.5           | CGM1-10       |
| CHM1-10     |                         | 8.0       | 16.0        |                                   |                                   |                                 |               |               |
| CHM1-11     |                         | 10.0      | 18.0        |                                   |                                   |                                 |               |               |

### **i** Features and options

- Gears, sprockets or dials assembled on request
- Imperial bores available
- Special hubs for Delrin gears

### **?** Technical support

- Recommended assembly procedure: Notch and stake in 4 equi-spaced positions and/or use adhesive (Loctite grade 326)





# Section Contents

Ball Bearings - P4.....Page 12-2

Bronze Bearings .....Page 12-3

Moulded Bearings.....Page 12-4

Bearing Pre-load Washers .....Page 12-5

Bearing Spacers .....Page 12-6

Technical Information.....Page T12-1



All dimensions in mm  
 Generally in accordance with ISO 492,  
 tolerance class 4  
 Material: X65Cr13 stainless steel

### Associated Products

Shafts: page 11-2  
 Bearing pre-load washers: page 12-5  
 Bearing spacers: page 12-6

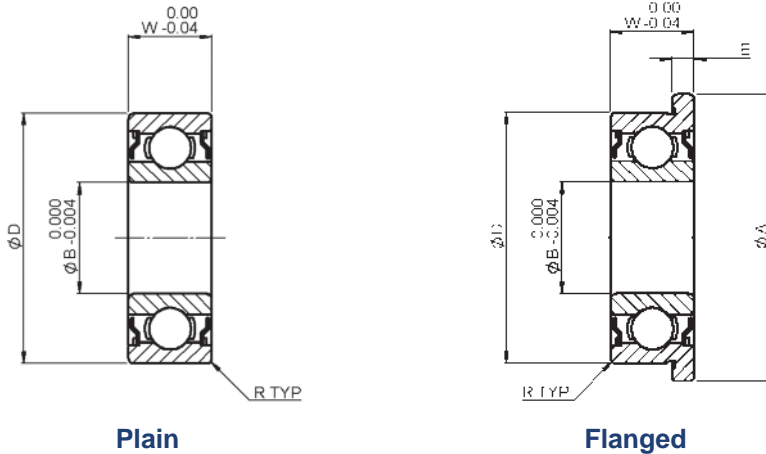

## Part number selection table

| Part Number |             | Dimensions     |           |        |            |                     |       |                  |     |                   |      | Specification     |              |
|-------------|-------------|----------------|-----------|--------|------------|---------------------|-------|------------------|-----|-------------------|------|-------------------|--------------|
| Plain       | Flanged     | Bore Dia<br>ØB | O/D<br>ØD |        | Width<br>W | Radii<br>R<br>(min) |       | Flange Dia<br>ØA |     | Flange Width<br>E |      | Load Ratings<br>N |              |
|             |             |                | Max       | Min    |            | Max                 | Min   | Max              | Min | Max               | Min  | Dynamic<br>C      | Static<br>Co |
| B1-102-S-P4 | B2-102-S-P4 | 2              | 5         | 4.996  | 2.3        | 0.08                | 6.15  | 6.05             | 0.6 | 0.56              | 192  | 59                |              |
| B1-103-S-P4 | B2-103-S-P4 | 3              | 7         | 6.996  | 3.0        | 0.10                | 8.15  | 8.05             | 0.8 | 0.76              | 432  | 149               |              |
| B1-104-S-P4 | B2-104-S-P4 | 4              | 9         | 8.996  | 4.0        | 0.10                | 10.35 | 10.25            | 1.0 | 0.96              | 658  | 226               |              |
| B1-105-S-P4 | B2-105-S-P4 | 5              | 11        | 10.996 | 5.0        | 0.15                | 12.55 | 12.45            | 1.0 | 0.92              | 734  | 282               |              |
| B1-106-S-P4 | B2-106-S-P4 | 6              | 13        | 12.996 | 5.0        | 0.15                | 15.05 | 14.95            | 1.1 | 1.02              | 1096 | 437               |              |
| B1-108-S-P4 | B2-108-S-P4 | 8              | 16        | 15.996 | 6.0        | 0.20                | 18.05 | 17.95            | 1.3 | 1.22              | 1795 | 776               |              |
| B1-110-S-P4 | B2-110-S-P4 | 10             | 19        | 18.995 | 7.0        | 0.30                | 21.05 | 20.95            | 1.5 | 1.38              | 1922 | 915               |              |

### Features and options

- Operating temperature range: -73°C to +121°C
- Lubricant: grease to MIL-G-21164 and MIL-G-23827
- Double shielded
- Imperial sizes available

### Technical support

- Spur gear and bearing load calculation - see page T12-1
- Bearing force sharing - see page T12-3
- Bearing installation and housing considerations - see page T12-4





Associated Products  
Shafts: page 11-2

All dimensions in mm  
General tolerances  $\pm 0.13$  mm  
Material: Bronze ASTM B 438  
Type 2, Grade 1

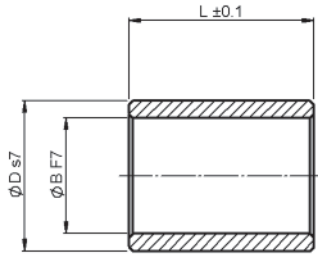

Plain

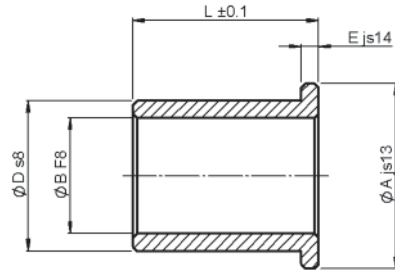

Flanged

### Part number selection table

| Part Number |         | Bore<br>$\varnothing B^1$ | O/D<br>$\varnothing D$ | Length<br>L | Flange Dia<br>$\varnothing A$ | Flange Width<br>E |
|-------------|---------|---------------------------|------------------------|-------------|-------------------------------|-------------------|
| Plain       | Flanged |                           |                        |             |                               |                   |
| BBM1-3      | BBM2-3  | 3                         | 6                      | 6           | 9                             | 1.5               |
| BBM1-4      | BBM2-4  | 4                         | 8                      | 12          | 12                            | 2.0               |
| BBM1-5      | BBM2-5  | 5                         | 8                      | 12          | --                            | --                |
| BBM1-6      | BBM2-6  | 6                         | 10                     | 12          | 14                            | 2.0               |
| BBM1-8      | BBM2-8  | 8                         | 12                     | 12          | 16                            | 2.0               |
| BBM1-10     | BBM2-10 | 10                        | 13                     | 16          | 16                            | 1.5               |

<sup>1</sup>Bearing bore tolerances after assembly are: plain bearings H7, flanged bearings H8.  
Recommended housing bore H7

### **i** Features and options

- Operating temperature range:  $-20^{\circ}\text{C}$  to  $+100^{\circ}\text{C}$
- Oil impregnated
- Max speed 30,000 rpm
- p.v (@0.5 m/s) = 1.75 N/mm<sup>2</sup>.m/s
- $P_{\text{max}} = 13.8$  N/mm
- $v_{\text{max}} = 6.1$  m/s (rotational)
- Imperial sizes available



Bearings and Spacers



All dimensions in mm  
 General tolerances  $\pm 0.13$  mm  
 Material: Self lubricating moulded thermo-plastic

**Associated Products**  
 Shafts: page 11-2  
 Leadscrews: page 7-1  
 Bearing spacers: page 12-6

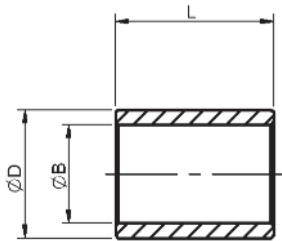

**Plain**

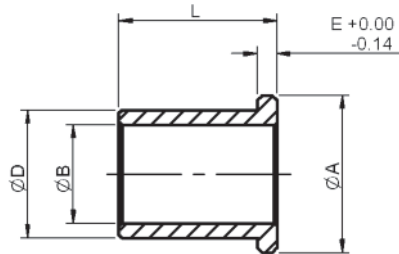

**Flanged**

### Part number selection table

| Part Number |         | Bore<br>ØB # | O/D<br>ØD | Length<br>L | Flange Dia<br>ØA | Flange Width<br>E |
|-------------|---------|--------------|-----------|-------------|------------------|-------------------|
| Plain       | Flanged |              |           |             |                  |                   |
| BM8-2       | -----   | 2.054        | 3.5       | 3.00        | -----            | -----             |
|             |         | 2.014        |           | 2.86        |                  |                   |
| BM8-3       | BM9-3   | 3.054        | 4.5       | 3.00        | 7.46             | 0.75              |
|             |         | 3.014        |           | 2.86        | 7.24             |                   |
| BM8-4       | BM9-4   | 4.068        | 5.5       | 4.00        | 9.46             | 0.75              |
|             |         | 4.020        |           | 3.82        | 9.24             |                   |
| BM8-5       | -----   | 5.040        | 7.0       | 5.00        | -----            | -----             |
|             |         | 5.010        |           | 4.82        |                  |                   |
| -----       | BM9-5   | 5.068        | 7.0       | 5.00        | 10.95            | 1.00              |
|             |         | 5.020        |           | 4.82        | 10.68            |                   |
| BM8-6       | BM9-6   | 6.068        | 8.0       | 6.00        | 11.95            | 1.00              |
|             |         | 6.020        |           | 5.82        | 11.68            |                   |
| BM8-8       | -----   | 8.083        | 10.0      | 8.00        | -----            | -----             |
|             |         | 8.025        |           | 7.78        |                  |                   |
| -----       | BM9-8   | 8.083        | 10.0      | 9.50        | 14.95            | 1.00              |
|             |         | 8.025        |           | 9.28        | 14.68            |                   |
| BM8-10      | BM9-10  | 10.083       | 12.0      | 10.00       | 17.95            | 1.00              |
|             |         | 10.025       |           | 9.78        | 17.68            |                   |
| BM8-12      | BM9-12  | 12.102       | 14.0      | 12.00       | 19.93            | 1.00              |
|             |         | 12.032       |           | 11.73       | 19.61            |                   |

# Tolerance for ØB is after press fitting into a housing bore of tolerance H7

### **i** Features and options

- Operating temperature range: -40°C to +130°C
- $(p.v)_{max} = 1.0$  N/mm<sup>2</sup>.m/s
- $p_{max} = 80$  N/mm<sup>2</sup>
- $v_{max} = 1.0$  m/s (rotational) or 4.0 m/s (linear)
- Imperial sizes available





**Associated Products**  
 Internal circlips: page 13-21  
 Bearings: page 12-2

All dimensions in mm  
 General tolerances  $\pm 0.13$  mm  
 Material: Stainless steel 300 series  
 Treatment: Spring tempered

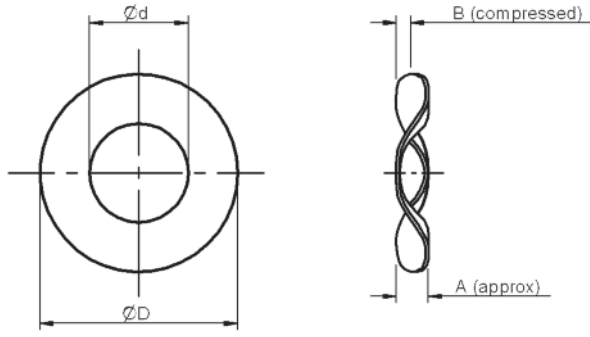

### Part number selection table

| Part Number | Housing Bore (nominal) | O/D ØD | Bore Ød | Free Height A | Compressed Height B | Load in N to Deflect to B |
|-------------|------------------------|--------|---------|---------------|---------------------|---------------------------|
| EPL-1       | 10                     | 9.5    | 4.5     | 1.2           | 1.0                 | 15                        |
| EPL-2       | 13                     | 12.5   | 7.5     | 1.5           |                     | 19                        |
| EPL-4       | 16                     | 15.5   | 10.5    | 1.5           |                     | 19                        |
| EPL-8       | 19                     | 18.5   | 13.0    | 1.5           |                     | 29                        |
| EPL-10      | 21                     | 20.5   | 15.0    | 1.8           |                     | 29                        |

### **i** Features and options

- Imperial bearing pre-load washers
- Available in spring steel, add **-ST** to part number eg **EPL-4-ST**



All dimensions in mm  
 General tolerances  $\pm 0.13$  mm  
 Material: Stainless steel 300 series

**Associated Products**  
 Shafts: page 11-2  
 Leadscrews: page 7-1  
 Bearings: page 12-2

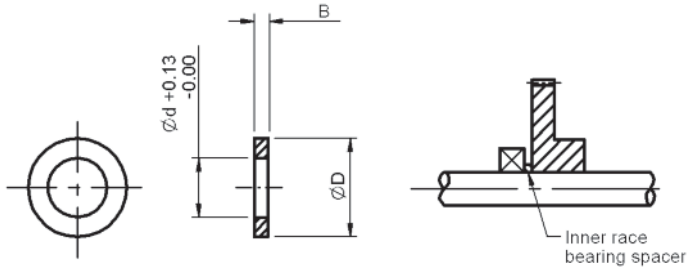

## Dimensions

| Shaft Nominal | Spacer Bore $\varnothing d$ | Spacer O/D $\varnothing D$ |
|---------------|-----------------------------|----------------------------|
| 2             | 2                           | 3.0                        |
| 3             | 3                           | 4.1                        |
| 4             | 4                           | 5.3                        |
| 5             | 5                           | 6.7                        |
| 6             | 6                           | 7.9                        |
| 8             | 8                           | 10.2                       |
| 10            | 10                          | 12.3                       |

## Part number selection table

| Nominal Shaft Dia $\varnothing d$ | Thickness B |         |         |         |         |         |         |         |
|-----------------------------------|-------------|---------|---------|---------|---------|---------|---------|---------|
|                                   | $\pm 0.025$ |         |         |         |         |         |         |         |
|                                   | 0.05        | 0.10    | 0.15    | 0.20    | 0.25    | 0.30    | 0.40    | 0.50    |
| 2                                 | SS1-117     | SS1-118 | SS1-119 | SS1-120 | SS1-121 | SS1-122 | SS1-123 | SS1-124 |
| 3                                 | SS1-125     | SS1-126 | SS1-127 | SS1-128 | SS1-129 | SS1-130 | SS1-131 | SS1-132 |
| 4                                 | SS1-133     | SS1-101 | SS1-102 | SS1-134 | SS1-103 | SS1-135 | SS1-104 | SS1-136 |
| 5                                 | SS1-137     | SS1-138 | SS1-139 | SS1-140 | SS1-141 | SS1-142 | SS1-143 | SS1-144 |
| 6                                 | SS1-145     | SS1-105 | SS1-106 | SS1-146 | SS1-107 | SS1-147 | SS1-108 | SS1-148 |
| 8                                 | SS1-149     | SS1-109 | SS1-110 | SS1-150 | SS1-111 | SS1-151 | SS1-112 | SS1-152 |
| 10                                | SS1-153     | SS1-113 | SS1-114 | SS1-154 | SS1-115 | SS1-155 | SS1-116 | SS1-156 |

## **i** Product options

- Imperial sizes available



**Associated Products**  
 Internal circlips: page 13-21  
 Bearings: page 12-2

All dimensions in mm  
 General tolerances  $\pm 0.13$  mm  
 Material: Stainless steel 300 series

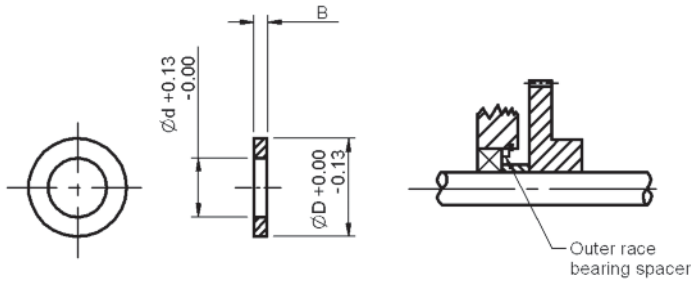

## Dimensions

| Bearing OD<br>Nominal | Spacer O/D<br>$\varnothing D$ | Spacer Bore<br>$\varnothing d$ |
|-----------------------|-------------------------------|--------------------------------|
| 5                     | 5                             | 4.2                            |
| 7                     | 7                             | 5.7                            |
| 9                     | 9                             | 7.8                            |
| 11                    | 11                            | 9.7                            |
| 13                    | 13                            | 11.1                           |
| 16                    | 16                            | 13.8                           |
| 19                    | 19                            | 16.6                           |

## Part number selection table

| Bearing <sup>1</sup> |             | Thickness B |         |         |         |         |         |         |         |
|----------------------|-------------|-------------|---------|---------|---------|---------|---------|---------|---------|
| Bore<br>(nom)        | OD<br>(nom) | $\pm 0.025$ |         |         |         |         |         |         |         |
|                      |             | 0.05        | 0.10    | 0.15    | 0.20    | 0.25    | 0.30    | 0.40    | 0.50    |
| 2                    | 5           | SS3-113     | SS3-114 | SS3-115 | SS3-116 | SS3-117 | SS3-118 | SS3-119 | SS3-120 |
| 3                    | 7           | SS3-121     | SS3-122 | SS3-123 | SS3-124 | SS3-125 | SS3-126 | SS3-127 | SS3-128 |
| 4                    | 9           | SS3-129     | SS3-130 | SS3-101 | SS3-131 | SS3-102 | SS3-132 | SS3-103 | SS3-133 |
| 5                    | 11          | SS3-134     | SS3-135 | SS3-136 | SS3-137 | SS3-138 | SS3-139 | SS3-140 | SS3-141 |
| 6                    | 13          | SS3-142     | SS3-143 | SS3-104 | SS3-144 | SS3-105 | SS3-145 | SS3-106 | SS3-146 |
| 8                    | 16          | SS3-147     | SS3-148 | SS3-107 | SS3-149 | SS3-108 | SS3-150 | SS3-109 | SS3-151 |
| 10                   | 19          | SS3-152     | SS3-153 | SS3-110 | SS3-154 | SS3-111 | SS3-155 | SS3-112 | SS3-157 |

<sup>1</sup> Applies to standard Reliance bearing sizes

## **i** Product options

- Imperial sizes available





## Section Contents

|                               |            |
|-------------------------------|------------|
| Plain Socket Head Screws..... | Page 13-2  |
| Wire Locking Screws .....     | Page 13-3  |
| Captive Screws .....          | Page 13-4  |
| Ventilation Screws .....      | Page 13-5  |
| Shoulder Screws .....         | Page 13-6  |
| Machine Screws                |            |
| - Countersunk .....           | Page 13-8  |
| - Pan Head .....              | Page 13-9  |
| - Cheese Head .....           | Page 13-10 |
| Cup Point Set Screws .....    | Page 13-11 |
| Solder Tip Set Screws .....   | Page 13-12 |
| Nylon Tip Set Screws .....    | Page 13-13 |
| Clamp Cleats .....            | Page 13-14 |
| Disc Springs .....            | Page 13-15 |
| Nuts .....                    | Page 13-16 |
| Washers .....                 | Page 13-17 |
| Coiled Pins .....             | Page 13-18 |
| Dowel Pins.....               | Page 13-19 |
| External Circlips .....       | Page 13-20 |
| Internal Circlips.....        | Page 13-21 |
| Technical Information.....    | Page T13-1 |



All dimensions in mm  
 Thread specification: BS3643 Pt2  
 Tolerance class: 6g  
 Material: A2-70 Austenitic<sup>(1)</sup>  
 A4-70 Austenitic<sup>(2)</sup>  
 Stainless steel to ISO 3506-1

**Associated Products**  
 Disc springs: page 13-15  
 Nuts: page 13-16  
 Washers: page 13-17

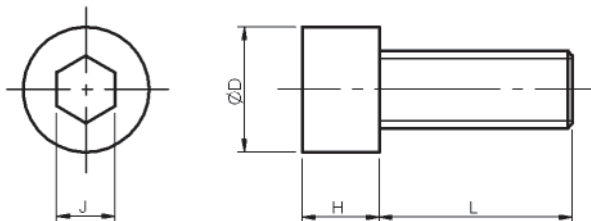

## Part number selection table

| Example Part No:- |             |        |       |       |                 |   | <b>S - M3 - 12 - A47</b> |   |   |    |    |    |    |                    |    |                    |
|-------------------|-------------|--------|-------|-------|-----------------|---|--------------------------|---|---|----|----|----|----|--------------------|----|--------------------|
| Basic Part No     | Thread Size | ØD max | H max | J nom | Standard Length |   |                          |   |   |    |    |    |    |                    |    | Matl               |
|                   |             |        |       |       | L               |   |                          |   |   |    |    |    |    |                    |    |                    |
| S                 | M1.6        | 3.0    | 1.6   | 1.5   | 3               | 4 | 5                        | 6 | 8 |    |    |    |    |                    |    | A27 <sup>(1)</sup> |
|                   | M2          | 3.8    | 2.0   | 1.5   |                 | 4 | 5                        | 6 | 8 |    |    |    |    |                    |    |                    |
|                   | M2.5        | 4.5    | 2.5   | 2.0   |                 |   | 5                        | 6 | 8 | 10 |    |    |    |                    |    |                    |
|                   | M3          | 5.5    | 3.0   | 2.5   |                 |   |                          | 6 | 8 | 10 | 12 | 16 | 20 | A47 <sup>(2)</sup> |    |                    |
|                   | M4          | 7.0    | 4.0   | 3.0   |                 |   |                          |   | 8 | 10 | 12 | 16 | 20 |                    | 25 |                    |
|                   | M5          | 8.5    | 5.0   | 4.0   |                 |   |                          |   |   | 10 | 12 | 16 | 20 |                    | 25 | 30                 |
| M6                | 10.0        | 6.0    | 5.0   |       |                 |   |                          |   |   | 12 | 16 | 20 | 25 |                    | 30 | 40                 |

### **i** Features and options

- Plain socket head cap screw to ISO 4762
- 700 MPa minimum tensile strength
- Rolled thread for excellent surface finish, superior thread strength and increased hardness properties
- Slotted head available
- Imperial sizes available
- Alternative materials available

### **?** Technical support

- ISO metric screw threads, limits and tolerances - see page T13-1
- Torque and tension guidelines - see page T13-1
- Material properties - see page T13-2



**Associated Products**  
 Disc springs: page 13-15  
 Nuts: page 13-16  
 Washers: page 13-17

All dimensions in mm  
 Thread specification: BS3643 Pt2  
 Tolerance class: 6g  
 Material: A2-70 Austenitic<sup>(1)</sup>  
 A4-70 Austenitic<sup>(2)</sup>  
 Stainless steel to ISO 3506-1

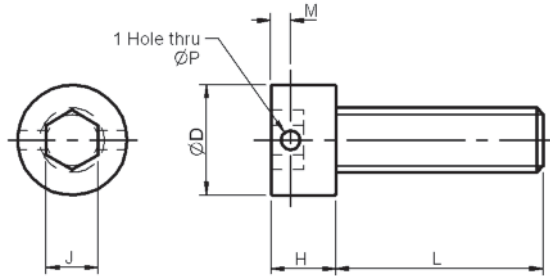

## Part number selection table

| Example Part No:- <b>S - M3 - 12 - A47 - XD</b> |             |        |       |       |        |         |                 |    |    |    |                    |    |    |
|---|-------------|--------|-------|-------|--------|---------|-----------------|----|----|----|--------------------|----|----|
| Basic Part No                                   | Thread Size | ØD max | H max | J nom | M ±0.1 | ØP ±0.1 | Standard Length |    |    |    | Matl               |    |    |
|   |             |        |       |       |        |         | L               |    |    |    |                    |    |    |
| S   | M1.6        | 3.0    | 1.6   | 1.5   | 0.5    | 0.4     | 3               | 4  | 5  | 6  | A27 <sup>(1)</sup> |    |    |
|   | M2          | 3.8    | 2.0   | 1.5   | 0.7    | 0.6     | 4               | 5  | 6  | 8  |                    |    |    |
|   | M2.5        | 4.5    | 2.5   | 2.0   | 0.75   | 0.7     | 5               | 6  | 8  | 10 | A47 <sup>(2)</sup> |    |    |
|   | M3          | 5.5    | 3.0   | 2.5   | 0.9    | 0.8     | 6               | 8  | 10 | 12 |                    | 16 | 20 |
|   | M4          | 7.0    | 4.0   | 3.0   | 1.3    | 1.0     | 8               | 10 | 12 | 16 |                    | 20 | 25 |
|   | M5          | 8.5    | 5.0   | 4.0   | 1.5    | 1.5     | 10              | 12 | 16 | 20 |                    | 25 | 30 |
| M6  | 10.0        | 6.0    | 5.0   | 1.8   | 1.5    | 1.5     | 12              | 16 | 20 | 25 | 30                 | 40 |    |

### **i** Features and options

- Plain socket head cap screw to ISO 4762 with cross-drilled head to allow fastener retention by wire locking
- 700 MPa minimum tensile strength
- Rolled thread for excellent surface finish, superior thread strength and increased hardness properties
- Imperial sizes available
- Alternative materials available

### **?** Technical support

- ISO metric screw threads, limits and tolerances - see page T13-1
- Torque and tension guidelines - see page T13-1
- Material properties - see page T13-2



All dimensions in mm  
 Thread specification: BS3643 Pt2  
 Tolerance class: 6g  
 Material: A2-70 Austenitic<sup>(1)</sup>  
 A4-70 Austenitic<sup>(2)</sup>  
 Stainless steel to ISO 3506-1

**Associated Products**  
 Disc springs: page 13-15  
 Nuts: page 13-16  
 Washers: page 13-17

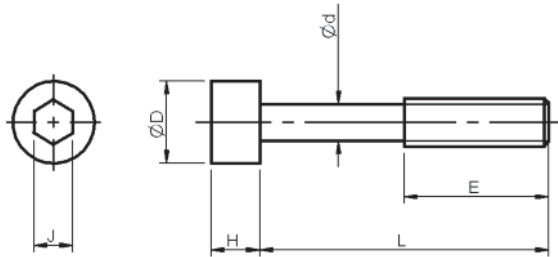

## Part number selection table

| Example Part No:- <b>S - M3 - 16 - A47 - CA</b> |             |        |       |       |         |        |                   |                    |
|---|-------------|--------|-------|-------|---------|--------|-------------------|--------------------|
| Basic Part No                                   | Thread Size | ØD max | H max | J nom | Ød ±0.1 | E ±0.1 | Standard Length L | Matl               |
| S   | M2          | 3.8    | 2.0   | 1.5   | 1.4     | 4.0    | 10                | A27 <sup>(1)</sup> |
|   | M2.5        | 4.5    | 2.5   | 2.0   | 1.8     | 5.0    | 12                | A47 <sup>(2)</sup> |
|   | M3          | 5.5    | 3.0   | 2.5   | 2.2     | 6.0    | 16 20             |                    |
|   | M4          | 7.0    | 4.0   | 3.0   | 3.0     | 8.0    | 20 25             |                    |
|   | M5          | 8.5    | 5.0   | 4.0   | 3.8     | 10.0   | 25 30             |                    |
|   | M6          | 10.0   | 6.0   | 5.0   | 4.5     | 12.0   | 30 40             |                    |

### **i** Features and options

- Socket head cap screw to ISO 4762 with plain shank length for captive assembly of the screw to prevent fastener loss
- Ideal for service covers
- Rolled thread for excellent surface finish, superior thread strength and increased hardness properties
- Slotted head available on sized M2 to M5
- Imperial sizes available
- Alternative materials available

### **?** Technical support

- ISO metric screw threads, limits and tolerances - see page T13-1
- Torque and tension guidelines - see page T13-1
- Material properties - see page T13-2



**Associated Products**  
 Disc springs: page 13-15  
 Nuts: page 13-16  
 Washers: page 13-17

All dimensions in mm  
 Thread specification: BS3643 Pt2  
 Tolerance class: 6g  
 Material: A2-70 Austenitic<sup>(1)</sup>  
 A4-70 Austenitic<sup>(2)</sup>  
 Stainless steel to ISO 3506-1

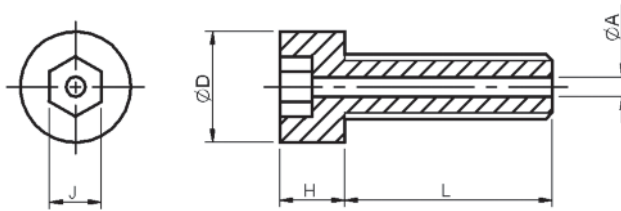

## Part number selection table

| Example Part No:-      |             |        |       |       |          |                 |    |    |    |                    |    |    |
|------------------------|-------------|--------|-------|-------|----------|-----------------|----|----|----|--------------------|----|----|
| S - M3 - 12 - A47 - AD |             |        |       |       |          |                 |    |    |    |                    |    |    |
| Basic Part No          | Thread Size | ØD max | H max | J nom | ØA ±0.05 | Standard Length |    |    |    | Matl               |    |    |
|                        |             |        |       |       |          | L               |    |    |    |                    |    |    |
| S                      | M1.6        | 3.0    | 1.6   | 1.5   | 0.6      | 3               | 4  | 5  | 6  | A27 <sup>(1)</sup> |    |    |
|                        | M2          | 3.8    | 2.0   | 1.5   | 0.7      | 4               | 5  | 6  | 8  |                    |    |    |
|                        | M2.5        | 4.5    | 2.5   | 2.0   | 0.8      | 5               | 6  | 8  | 10 | A47 <sup>(2)</sup> |    |    |
|                        | M3          | 5.5    | 3.0   | 2.5   | 1.0      | 6               | 8  | 10 | 12 |                    | 16 | 20 |
|                        | M4          | 7.0    | 4.0   | 3.0   | 1.0      | 8               | 10 | 12 | 16 |                    | 20 | 25 |
|                        | M5          | 8.5    | 5.0   | 4.0   | 1.5      | 10              | 12 | 16 | 20 |                    | 25 | 30 |
| M6                     | 10.0        | 6.0    | 5.0   | 1.5   | 12       | 16              | 20 | 25 | 30 | 40                 |    |    |

### **i** Features and options

- Socket head cap screw to ISO 4762 drilled through on axis to assist cavity ventilation in vacuum assemblies
- Rolled thread for excellent surface finish, superior thread strength and increased hardness properties
- Slotted head available
- Imperial sizes available
- Alternative materials available

### **?** Technical support

- ISO metric screw threads, limits and tolerances - see page T13-1
- Torque and tension guidelines - see page T13-1
- Material properties - see page T13-2



All dimensions in mm  
 Material: 303 Stainless steel  
 Tolerance class: 6g

**Associated Products**  
 Disc springs: page 13-15  
 Nuts: page 13-16  
 Washers: page 13-17

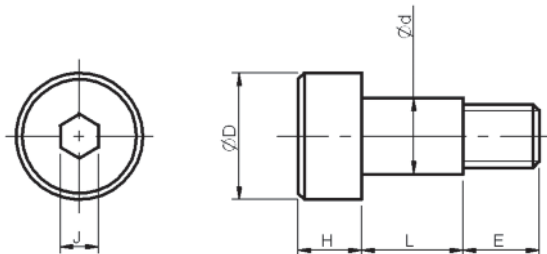

**Part number selection table**

| Example Part No:- <b>MSS2 - M6 - 35</b> |             |                        |    |          |   |           |                            |             |
|---|-------------|------------------------|----|----------|---|-----------|----------------------------|-------------|
| Basic Part Number                       | Thread Size | Ød<br>+0.000<br>-0.025 | ØD | J<br>nom | H | E<br>±0.1 | Length L<br>+0.05<br>-0.00 | Length Code |
| <b>MSS2</b>                             | <b>M3</b>   | 3.987                  | 6  | 2        | 3 | 4         | 4.013                      | <b>1</b>    |
|   |             |                        |    |          |   |           | 5.013                      | <b>2</b>    |
|   |             |                        |    |          |   |           | 6.013                      | <b>3</b>    |
|   |             |                        |    |          |   |           | 8.013                      | <b>4</b>    |
|   |             |                        |    |          |   |           | 10.013                     | <b>5</b>    |
|   | <b>M4</b>   | 4.987                  | 8  | 2.5      | 4 | 5         | 4.013                      | <b>6</b>    |
|   |             |                        |    |          |   |           | 5.013                      | <b>7</b>    |
|   |             |                        |    |          |   |           | 6.013                      | <b>8</b>    |
|   |             |                        |    |          |   |           | 8.013                      | <b>9</b>    |
|   |             |                        |    |          |   |           | 10.013                     | <b>10</b>   |
|   |             |                        |    |          |   |           | 12.013                     | <b>11</b>   |
|   |             |                        |    |          |   |           | 14.013                     | <b>12</b>   |
|   |             |                        |    |          |   |           | 16.013                     | <b>13</b>   |
|   |             |                        |    |          |   |           | 20.013                     | <b>14</b>   |
|   |             |                        |    |          |   |           | 25.013                     | <b>15</b>   |
|   |             |                        |    |          |   |           | 30.013                     | <b>16</b>   |
|   | <b>M5</b>   | 5.987                  | 10 | 3        | 5 | 6         | 4.013                      | <b>17</b>   |
|   |             |                        |    |          |   |           | 5.013                      | <b>18</b>   |
|   |             |                        |    |          |   |           | 6.013                      | <b>19</b>   |
|   |             |                        |    |          |   |           | 8.013                      | <b>20</b>   |
|   |             |                        |    |          |   |           | 10.013                     | <b>21</b>   |
|   |             |                        |    |          |   |           | 12.013                     | <b>22</b>   |
|   |             |                        |    |          |   |           | 14.013                     | <b>23</b>   |
|   |             |                        |    |          |   |           | 16.013                     | <b>24</b>   |
|   |             |                        |    |          |   |           | 20.013                     | <b>25</b>   |
|   |             |                        |    |          |   |           | 25.013                     | <b>26</b>   |
|   |             |                        |    |          |   |           | 30.013                     | <b>27</b>   |

Screws and Hardware



| Basic Part Number | Thread Size | Ød<br>+0.000<br>-0.025 | ØD | J<br>nom | H | E<br>±0.1 | Length L<br>+0.05<br>-0.00 | Length Code |    |   |   |    |        |    |
|-------------------|-------------|------------------------|----|----------|---|-----------|----------------------------|-------------|----|---|---|----|--------|----|
| MSS2              | M6          | 7.987                  | 12 | 4        | 6 | 11        | 6.013                      | 28          |    |   |   |    |        |    |
|                   |             |                        |    |          |   |           | 8.013                      | 29          |    |   |   |    |        |    |
|                   |             |                        |    |          |   |           | 10.013                     | 30          |    |   |   |    |        |    |
|                   |             |                        |    |          |   |           | 12.013                     | 31          |    |   |   |    |        |    |
|                   |             |                        |    |          |   |           | 16.013                     | 32          |    |   |   |    |        |    |
|                   |             |                        |    |          |   |           | 20.013                     | 33          |    |   |   |    |        |    |
|                   | M8          | 9.987                  | 14 | 5        | 7 | 12        | 8.013                      | 34          |    |   |   |    |        |    |
|                   |             |                        |    |          |   |           | 10.013                     | 35          |    |   |   |    |        |    |
|                   |             |                        |    |          |   |           | 12.013                     | 36          |    |   |   |    |        |    |
|                   |             |                        |    |          |   |           | 16.013                     | 37          |    |   |   |    |        |    |
|                   |             |                        |    |          |   |           | M10                        | 11.987      | 20 | 6 | 8 | 16 | 12.013 | 42 |
|                   |             |                        |    |          |   |           |                            |             |    |   |   |    | 16.013 | 43 |
| 20.013            | 44          |                        |    |          |   |           |                            |             |    |   |   |    |        |    |
| 25.013            | 45          |                        |    |          |   |           |                            |             |    |   |   |    |        |    |

### **i** Features and options

- Socket head screw with accurate diameter shoulder for precision assemblies
- May be used to replace components such as shafts, pivots, pins and guides
- Used for linkages and stationary guides
- Slotted head and Phillips head available
- Imperial sizes available
- Alternative materials available (416)  
add -4 to the end of the part number
- Alternative lengths available

### **?** Technical support

- ISO metric screw threads, limits and tolerances - see [page T13-1](#)
- Torque and tension guidelines - see [page T13-1](#)
- Material properties - see [page T13-2](#)



All dimensions in mm  
 Thread specification: BS3643 Pt2  
 Head specification: BS4183  
 Tolerance class: 6g  
 Material: Stainless steel 300 series

**Associated Products**  
 Disc springs: page 13-15  
 Nuts: page 13-16  
 Washers: page 13-17

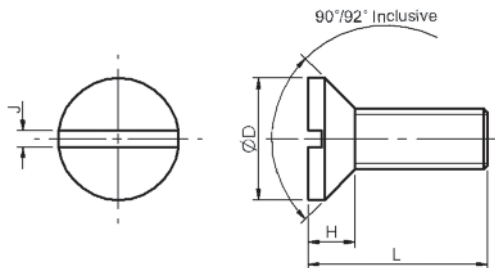

### Part number selection table

| Example Part No:- |             |        |       |       |                 | <b>K - M3 - 12</b> |   |   |   |    |    |    |    |    |    |    |  |  |  |  |  |  |  |  |
|-------------------|-------------|--------|-------|-------|-----------------|--------------------|---|---|---|----|----|----|----|----|----|----|--|--|--|--|--|--|--|--|
| Basic Part No     | Thread Size | ØD max | H max | J nom | Standard Length |                    |   |   |   |    |    |    |    |    |    |    |  |  |  |  |  |  |  |  |
|                   |             |        |       |       | L               |                    |   |   |   |    |    |    |    |    |    |    |  |  |  |  |  |  |  |  |
| K                 | M2          | 4.4    | 1.20  | 0.63  | 3               | 4                  | 5 | 6 | 8 | 10 | 12 | 16 | 20 |    |    |    |  |  |  |  |  |  |  |  |
|                   | M2.5        | 5.5    | 1.50  | 0.73  |                 |                    | 5 | 6 | 8 | 10 | 12 | 16 | 20 | 25 |    |    |  |  |  |  |  |  |  |  |
|                   | M3          | 6.3    | 1.65  | 0.93  |                 |                    | 5 | 6 | 8 | 10 | 12 | 16 | 20 | 25 | 30 |    |  |  |  |  |  |  |  |  |
|                   | M4          | 8.4    | 2.20  | 1.13  |                 |                    |   | 6 | 8 | 10 | 12 | 16 | 20 | 25 | 30 | 35 |  |  |  |  |  |  |  |  |
|                   | M5          | 10.0   | 2.50  | 1.38  |                 |                    |   |   | 8 | 10 | 12 | 16 | 20 | 25 | 30 | 35 |  |  |  |  |  |  |  |  |
|                   | M6          | 12.0   | 3.00  | 1.78  |                 |                    |   |   |   | 10 | 12 | 16 | 20 | 25 | 30 | 35 |  |  |  |  |  |  |  |  |

### **i** Features and options

- Imperial sizes available
- Alternative materials available

### **?** Technical support

- ISO metric screw threads, limits and tolerances - see page T13-1
- Torque and tension guidelines - see page T13-1





**Associated Products**  
 Disc springs: page 13-15  
 Nuts: page 13-16  
 Washers: page 13-17

All dimensions in mm  
 Thread specification: BS3643 Pt2  
 Head specification: BS4183  
 Tolerance class: 6g  
 Material: Stainless steel 300 series

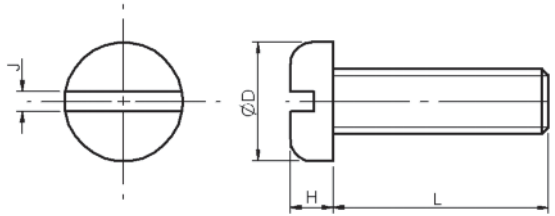

### Part number selection table

| Example Part No:- |             |        |       |       |                 | <b>P - M3 - 12</b> |   |   |   |    |    |    |    |    |    |    |  |  |  |  |
|-------------------|-------------|--------|-------|-------|-----------------|--------------------|---|---|---|----|----|----|----|----|----|----|--|--|--|--|
| Basic Part No     | Thread Size | ØD max | H max | J nom | Standard Length |                    |   |   |   |    |    |    |    |    |    |    |  |  |  |  |
|                   |             |        |       |       | L               |                    |   |   |   |    |    |    |    |    |    |    |  |  |  |  |
| P                 | M2          | 4.0    | 1.2   | 0.63  | 3               | 4                  | 5 | 6 | 8 | 10 | 12 | 16 | 20 |    |    |    |  |  |  |  |
|                   | M2.5        | 5.0    | 1.5   | 0.73  |                 |                    | 5 | 6 | 8 | 10 | 12 | 16 | 20 | 25 |    |    |  |  |  |  |
|                   | M3          | 6.0    | 1.8   | 0.93  |                 |                    | 5 | 6 | 8 | 10 | 12 | 16 | 20 | 25 | 30 |    |  |  |  |  |
|                   | M4          | 8.0    | 2.4   | 1.13  |                 |                    |   | 6 | 8 | 10 | 12 | 16 | 20 | 25 | 30 | 35 |  |  |  |  |
|                   | M5          | 10.0   | 3.0   | 1.38  |                 |                    |   |   | 8 | 10 | 12 | 16 | 20 | 25 | 30 | 35 |  |  |  |  |
|                   | M6          | 12.0   | 3.6   | 1.78  |                 |                    |   |   |   | 10 | 12 | 16 | 20 | 25 | 30 | 35 |  |  |  |  |

### **i** Features and options

- Imperial sizes available
- Alternative materials available

### **?** Technical support

- ISO metric screw threads, limits and tolerances - see page T13-1
- Torque and tension guidelines - see page T13-1



All dimensions in mm  
 Thread specification: BS3643 Pt2  
 Head specification: BS4183  
 Tolerance class: 6g  
 Material: Stainless steel 300 series

**Associated Products**  
 Disc springs: page 13-15  
 Nuts: page 13-16  
 Washers: page 13-17

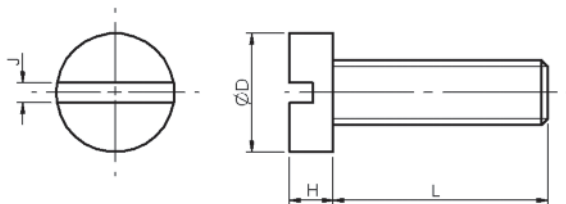

## Part number selection table

| Example Part No:- |             |        |       |       |                 | <b>C - M3 - 12</b> |   |   |   |    |    |    |    |    |    |    |  |  |  |  |
|-------------------|-------------|--------|-------|-------|-----------------|--------------------|---|---|---|----|----|----|----|----|----|----|--|--|--|--|
| Basic Part No     | Thread Size | ØD max | H max | J nom | Standard Length |                    |   |   |   |    |    |    |    |    |    |    |  |  |  |  |
|                   |             |        |       |       | L               |                    |   |   |   |    |    |    |    |    |    |    |  |  |  |  |
| C                 | M2          | 3.8    | 1.3   | 0.63  | 3               | 4                  | 5 | 6 | 8 | 10 | 12 | 16 | 20 |    |    |    |  |  |  |  |
|                   | M2.5        | 4.5    | 1.6   | 0.73  |                 |                    | 5 | 6 | 8 | 10 | 12 | 16 | 20 | 25 |    |    |  |  |  |  |
|                   | M3          | 5.5    | 2.0   | 0.93  |                 |                    | 5 | 6 | 8 | 10 | 12 | 16 | 20 | 25 | 30 |    |  |  |  |  |
|                   | M4          | 7.0    | 2.6   | 1.13  |                 |                    |   | 6 | 8 | 10 | 12 | 16 | 20 | 25 | 30 | 35 |  |  |  |  |
|                   | M5          | 8.5    | 3.3   | 1.38  |                 |                    |   |   | 8 | 10 | 12 | 16 | 20 | 25 | 30 | 35 |  |  |  |  |
|                   | M6          | 10.0   | 3.9   | 1.78  |                 |                    |   |   |   | 10 | 12 | 16 | 20 | 25 | 30 | 35 |  |  |  |  |

### **i** Features and options

- Imperial sizes available
- Alternative materials available

### **?** Technical support

- ISO metric screw threads, limits and tolerances - see page T13-1
- Torque and tension guidelines - see page T13-1



**Associated Products**  
 Gears: page 4-1  
 Reli-a-Flex® couplings: page 8-6

All dimensions in mm  
 Thread specification: BS3643 Pt2  
 Tolerance class: 6g  
 Material: Stainless steel  
 Manufactured to: BS EN ISO 4029

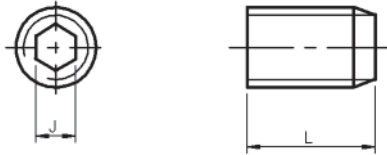

### Part number selection table

| Example Part No:- |             | <b>SS - M4 - 12</b> |                    |   |   |   |   |   |    |  |  |  |  |  |  |  |  |
|-------------------|-------------|---------------------|--------------------|---|---|---|---|---|----|--|--|--|--|--|--|--|--|
| Basic Part Number | Thread Size | J nom               | Standard Lengths L |   |   |   |   |   |    |  |  |  |  |  |  |  |  |
|                   |             |                     | 2                  | 3 | 4 | 5 | 6 | 8 | 10 |  |  |  |  |  |  |  |  |
| SS                | M2          | 0.9                 |                    |   |   |   |   |   |    |  |  |  |  |  |  |  |  |
|                   | M2.5        | 1.3                 |                    |   |   |   |   |   |    |  |  |  |  |  |  |  |  |
|                   | M3          | 1.5                 |                    |   |   |   |   |   |    |  |  |  |  |  |  |  |  |
|                   | M4          | 2                   |                    |   |   |   |   |   |    |  |  |  |  |  |  |  |  |
|                   | M5          | 2.5                 |                    |   |   |   |   |   |    |  |  |  |  |  |  |  |  |
|                   | M6          | 3                   |                    |   |   |   |   |   |    |  |  |  |  |  |  |  |  |

### **i** Features and options

- Used for quick, permanent location of gears, collars and pulleys on shafts
- Suitable for high torque transmission
- Imperial sizes available
- Alternative materials available

### **?** Technical support

- ISO metric screw threads, limits and tolerances - see page T13-1
- Torque and tension guidelines - see page T13-1



All dimensions in mm  
 Thread specification: BS3643 Pt2  
 Tolerance class: 6g  
 Material: Stainless steel 300 series with silver solder tip

**Associated Products**  
 Gears: page 4-1  
 Couplings: page 8-1

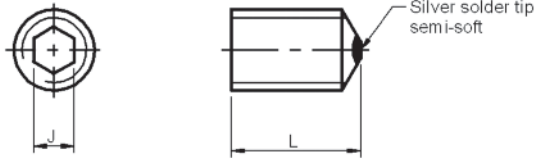

## Part number selection table

| Example Part No:- |             | <b>SGSS - M6 - 17</b> |                    |             |
|-------------------|-------------|-----------------------|--------------------|-------------|
| Basic Part Number | Thread Size | J nom                 | Standard Lengths L | Length Code |
| <b>SGSS</b>       | <b>M2</b>   | 0.9                   | 3                  | <b>1</b>    |
|                   |             |                       | 4                  | <b>2</b>    |
|                   |             |                       | 5                  | <b>3</b>    |
|                   |             |                       | 6                  | <b>4</b>    |
|                   | <b>M3</b>   | 1.5                   | 3                  | <b>5</b>    |
|                   |             |                       | 4                  | <b>6</b>    |
|                   |             |                       | 5                  | <b>7</b>    |
|                   |             |                       | 6                  | <b>8</b>    |
|                   | <b>M4</b>   | 2                     | 4                  | <b>9</b>    |
|                   |             |                       | 6                  | <b>10</b>   |
|                   |             |                       | 10                 | <b>11</b>   |
|                   |             |                       | 14                 | <b>12</b>   |
|                   | <b>M5</b>   | 2.5                   | 6                  | <b>13</b>   |
|                   |             |                       | 10                 | <b>14</b>   |
|                   |             |                       | 14                 | <b>15</b>   |
|                   |             |                       | 20                 | <b>16</b>   |
|                   | <b>M6</b>   | 3                     | 6                  | <b>17</b>   |
|                   |             |                       | 10                 | <b>18</b>   |
|                   |             |                       | 16                 | <b>19</b>   |
|                   |             |                       | 25                 | <b>20</b>   |

### **i** Features and options

- Stainless steel set screw with semi-soft silver solder tip
- Prevents shaft marking
- Imperial sizes available

### **?** Technical support

- ISO metric screw threads, limits and tolerances - see [page T13-1](#)
- Torque and tension guidelines - see [page T13-1](#)



**Associated Products**  
 Gears: page 4-1  
 Couplings: page 8-1

All dimensions in mm  
 Thread specification: BS3643 Pt2  
 Tolerance class: 6g  
 Material: Stainless steel screw  
 Nylon insert

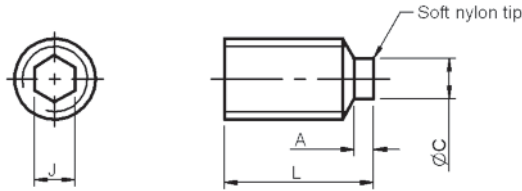

### Part number selection table

| Example Part No:- <b>NMSS - M5 - 16</b> |             |     |     |       |                    |             |
|---|-------------|-----|-----|-------|--------------------|-------------|
| Basic Part Number                       | Thread Size | ØC  | A   | J nom | Standard Lengths L | Length Code |
| NMSS                                    | M2          | 0.8 | 0.8 | 0.9   | 3.8                | 1           |
|   |             |     |     |       | 4.8                | 2           |
|   |             |     |     |       | 5.8                | 3           |
|   |             |     |     |       | 6.8                | 4           |
|   | M3          | 1.6 | 0.8 | 1.5   | 3.8                | 5           |
|   |             |     |     |       | 4.8                | 6           |
|   |             |     |     |       | 5.8                | 7           |
|   |             |     |     |       | 6.8                | 8           |
|   | M4          | 2.4 | 1.2 | 2     | 5.2                | 9           |
|   |             |     |     |       | 7.2                | 10          |
|   |             |     |     |       | 11.2               | 11          |
|   |             |     |     |       | 15.2               | 12          |
|   | M5          | 2.4 | 1.2 | 2.5   | 7.2                | 13          |
|   |             |     |     |       | 11.2               | 14          |
|   |             |     |     |       | 15.2               | 15          |
|   |             |     |     |       | 21.2               | 16          |
|   | M6          | 3.2 | 1.6 | 3     | 7.6                | 17          |
|   |             |     |     |       | 11.6               | 18          |
|   |             |     |     |       | 17.6               | 19          |
|   |             |     |     |       | 26.6               | 20          |

#### **i** Features and options

- Stainless steel set screw with nylon tip insert
- Used to prevent shaft marking
- Self locking
- Full face contact
- Imperial sizes available

#### **?** Technical support

- ISO metric screw threads, limits and tolerances - see [page T13-1](#)
- Torque and tension guidelines - see [page T13-1](#)



All dimensions in mm  
 General tolerances  $\pm 0.13$  mm  
 Material: Stainless steel clamp  
 Nylon locking insert

**Associated Products**  
 Gearboxes: page 3-1

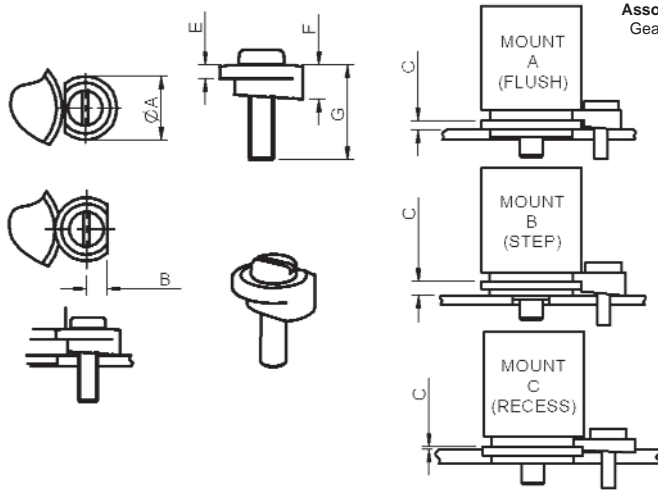

### Part number selection table

| Part Number   | Mount Type | Height C<br>$\pm 0.08$ | Flat B | Lip E<br>$\pm 0.08$ | Height F | Length G<br>$+0.0/-0.8$ | Thread Size | O/D<br>$\pm 0.00/-0.13$ |
|---------------|------------|------------------------|--------|---------------------|----------|-------------------------|-------------|-------------------------|
| <b>SQM-6</b>  | A & C      | 0.79                   | 3.18   | 1.02                | 1.80     | 7.0                     | M3 x 0.5    | 9.90                    |
| <b>SQM-7</b>  | A          | 1.57                   |        | 1.02                | 2.59     |                         |             |                         |
| <b>SQM-8</b>  |            | 1.57                   |        | 1.27                | 2.84     |                         |             |                         |
| <b>SQM-9</b>  |            | 1.57                   |        | 1.60                | 3.18     |                         |             |                         |
| <b>SQM-10</b> |            | 1.98                   |        | 1.60                | 3.58     |                         |             |                         |
| <b>SQM-11</b> |            | 2.36                   |        | 1.02                | 3.38     |                         |             |                         |
| <b>SQM-12</b> |            | 2.36                   |        | 1.27                | 3.63     |                         |             |                         |
| <b>SQM-13</b> |            | 2.36                   |        | 1.60                | 3.96     |                         |             |                         |
| <b>SQM-14</b> |            | B                      |        | 3.18                | 1.27     | 4.45                    |             |                         |
| <b>SQM-15</b> |            |                        |        | 3.96                | 1.02     | 4.98                    |             |                         |
| <b>SQM-16</b> |            |                        |        | 5.72                | 1.60     | 7.32                    |             |                         |
| <b>SQM-17</b> | A          | 6.35                   |        | 1.60                | 7.92     | 15.0                    |             |                         |

### **i** Features and options

- Ideal for use with resolvers, encoders and potentiometers
- Imperial sizes available
- Self locking
- Quick releasing



### Associated Products

Shafts: page 11-2  
Bearings: page 12-2  
Socket head cap screws: page 13-2  
Machine screws: page 13-8  
Nuts: page 13-16

All dimensions in mm  
General tolerances  $\pm 0.13$  mm  
Material: Stainless steel X12CrNi 17 7  
Manufactured to: DIN2093

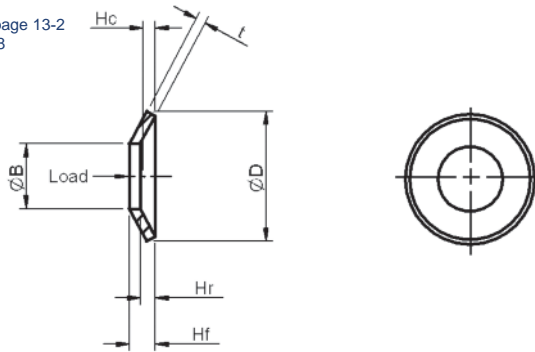

### Part number selection table

| Basic Part Number |            | Screw Size | ØD   | ØB                | t    | Free Height Hf | Ref. Height Hr | Compressed Height Hc (75% Defl.) | Force to Compress to Hc (N) |
|-------------------|------------|------------|------|-------------------|------|----------------|----------------|----------------------------------|-----------------------------|
| Example Part No:- |            |            |      |                   |      |                |                |                                  | <b>BW - M6</b>              |
| <b>BW</b>         | <b>M4</b>  | 8.0        | 4.2  | 0.40              | 0.60 | 0.20           | 0.45           | 193                              |                             |
|                   | <b>M5</b>  | 10.0       | 5.2  | 0.50              | 0.75 | 0.25           | 0.56           | 300                              |                             |
|                   | <b>M6</b>  | 12.5       | 6.2  | 0.70              | 0.95 | 0.25           | 0.76           | 503                              |                             |
|                   | <b>M7</b>  | 14.0       | 7.2  | 0.80              | 1.10 | 0.30           | 0.87           | 735                              |                             |
|                   | <b>M8</b>  | 16.0       | 8.2  | 0.90              | 1.25 | 0.35           | 0.99           | 934                              |                             |
|                   | <b>M10</b> | 20.0       | 10.2 | 1.10              | 1.55 | 0.45           | 1.21           | 1403                             |                             |
|                   | <b>M11</b> | 22.5       | 11.2 | 1.25 <sup>1</sup> | 1.65 | 0.40           | 1.35           | 1411                             |                             |
|                   | <b>M12</b> | 25.0       | 12.2 | 1.50 <sup>1</sup> | 1.90 | 0.40           | 1.60           | 1944                             |                             |

<sup>1</sup> Material: stainless steel X7CrNiAl 17 7

### **i** Features and options

- For use where controlled axial force is required
- Good for bearing pre-load configurations
- Imperial sizes available



All dimensions in mm  
 General tolerances  $\pm 0.13$  mm  
 Material: Stainless steel  
 Thread: BS3692, DIN 934

**Associated Products**  
 Disc springs: page 13-15  
 Plain socket head cap screws: page 13-2  
 Pan head machine screws: page 13-9  
 Cheese head machine screws: page 13-10  
 Washers: page 13-17

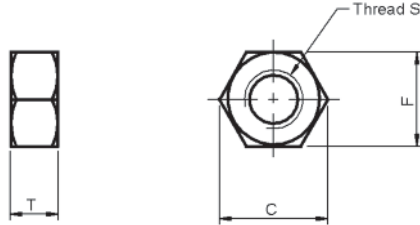

### Part number selection table

| Example Part No:- <b>HN - M3</b> |               |       |       |       |
|----------------------------------|---------------|-------|-------|-------|
| Basic Part Number                | Thread Size S | T max | F max | C nom |
| HN                               | M1.6          | 1.3   | 3.2   | 3.4   |
|                                  | M2            | 1.6   | 4.0   | 4.6   |
|                                  | M2.5          | 2.0   | 5.0   | 5.8   |
|                                  | M3            | 2.4   | 5.5   | 6.4   |
|                                  | M4            | 3.2   | 7.0   | 8.1   |
|                                  | M5            | 4.0   | 8.0   | 9.2   |
|                                  | M6            | 5.0   | 10.0  | 11.5  |

### **i** Product options

- Imperial sizes available



**Associated Products**  
Screws from: page 13-2  
Nuts: page 13-16  
Disc springs: page 13-15

All dimensions in mm  
General tolerances  $\pm 0.13$  mm  
Material: Stainless steel

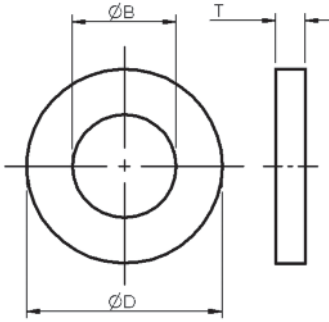

Plain Washers

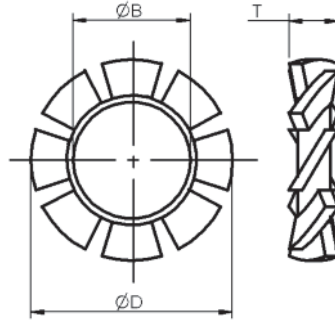

Tooth Lock Washers

### Part number selection tables

| Example Part No:- <b>PW - M3</b> |             |        |        |       |
|----------------------------------|-------------|--------|--------|-------|
| Basic Part Number                | Thread Size | ØD max | ØB min | T nom |
| <b>PW</b>                        | <b>M1.6</b> | 4.0    | 1.7    | 0.3   |
|                                  | <b>M2</b>   | 5.0    | 2.2    | 0.4   |
|                                  | <b>M2.5</b> | 6.5    | 2.7    | 0.6   |
|                                  | <b>M3</b>   | 7.0    | 3.2    | 0.6   |
|                                  | <b>M4</b>   | 9.0    | 4.3    | 0.9   |
|                                  | <b>M5</b>   | 10.0   | 5.3    | 1.1   |
|                                  | <b>M6</b>   | 12.5   | 6.4    | 1.8   |

| Example Part No:- <b>ETW - M3</b> |             |        |        |       |
|-----------------------------------|-------------|--------|--------|-------|
| Basic Part Number                 | Thread Size | ØD max | ØB max | T nom |
| <b>ETW</b>                        | <b>M2</b>   | 4.5    | 2.2    | 0.9   |
|                                   | <b>M3</b>   | 6.0    | 3.2    | 1.2   |
|                                   | <b>M4</b>   | 8.0    | 4.3    | 1.5   |
|                                   | <b>M5</b>   | 10.0   | 5.3    | 1.8   |
|                                   | <b>M6</b>   | 11.0   | 6.4    | 2.1   |

### **i** Product options

- Imperial sizes available



Ø0.8 - Ø3.0mm

Coiled Pins

All dimensions in mm  
 General tolerances ±0.13 mm  
 Material: Chrome stainless steel AISI 420  
 Finish: Pickled and oiled

**Associated Products**  
 Pin hub gears: page 4-13  
 Shaft collars: page 11-3

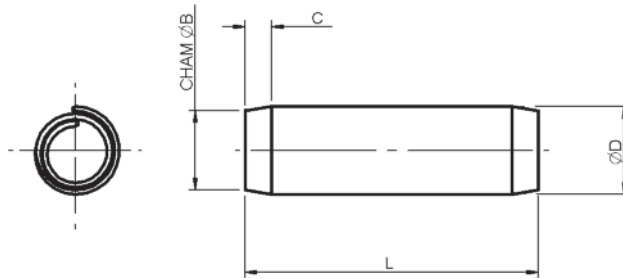

**Part number selection table**

| Example Part No:- |               |            |             |               |                |                  | <b>MSP - 1.5 - 6 - MCP</b> |          |          |           |           |           |           |           |           |  |
|-------------------|---------------|------------|-------------|---------------|----------------|------------------|----------------------------|----------|----------|-----------|-----------|-----------|-----------|-----------|-----------|--|
| Basic Part Number | Actual Dia ØD | Nom Dia    | Cham Dia ØB | Cham Length C | Ideal Hole Dia | Standard Lengths |                            |          |          |           |           |           |           |           |           |  |
|                   |               |            |             |               |                | L                |                            |          |          |           |           |           |           |           |           |  |
| <b>MSP</b>        | 0.85/0.91     | <b>0.8</b> | 0.75        | 0.30          | 0.80/0.84      | <b>4</b>         | <b>5</b>                   | <b>6</b> | <b>8</b> |           |           |           |           |           |           |  |
|                   | 1.05/1.15     | <b>1.0</b> | 0.95        | 0.30          | 1.00/1.04      | <b>4</b>         | <b>5</b>                   | <b>6</b> | <b>8</b> | <b>10</b> | <b>12</b> |           |           |           |           |  |
|                   | 1.62/1.73     | <b>1.5</b> | 1.40        | 0.50          | 1.50/1.60      |                  | <b>5</b>                   | <b>6</b> | <b>8</b> | <b>10</b> | <b>12</b> | <b>14</b> | <b>16</b> |           |           |  |
|                   | 2.13/2.25     | <b>2.0</b> | 1.90        | 0.70          | 1.99/2.10      |                  |                            | <b>6</b> | <b>8</b> | <b>10</b> | <b>12</b> | <b>14</b> | <b>16</b> | <b>18</b> |           |  |
|                   | 2.65/2.78     | <b>2.5</b> | 2.40        | 0.70          | 2.49/2.60      |                  |                            |          |          | <b>10</b> | <b>12</b> | <b>14</b> | <b>16</b> | <b>18</b> |           |  |
|                   | 3.15/3.30     | <b>3.0</b> | 2.90        | 0.90          | 2.99/3.10      |                  |                            |          |          |           |           | <b>14</b> | <b>16</b> | <b>18</b> | <b>20</b> |  |

**i Features and options**

- Coiled steel pin for location and alignment
- Suitable for locating Reliance's gears on ground shaft
- Imperial sizes available
- Alternative materials available

Screws and Hardware



**Associated Products**  
 Pin hub gears: page 4-13  
 Shaft collars: page 11-3

All dimensions in mm  
 General tolerances  $\pm 0.13$  mm  
 Material: Stainless steel 300 series

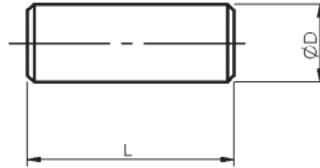

## Part number selection table

| Example Part No:- |                    | D 020 - 10    |                                     |      |     |   |   |    |    |    |    |    |    |    |    |  |
|-------------------|--------------------|---------------|-------------------------------------|------|-----|---|---|----|----|----|----|----|----|----|----|--|
| Basic Part Number | ØD<br>$\pm 0.0025$ | Diameter Code | Standard Lengths<br>L<br>$\pm 0.25$ |      |     |   |   |    |    |    |    |    |    |    |    |  |
|                   |                    |               | D                                   | 1.00 | 010 | 3 | 4 | 5  | 6  | 8  | 10 | 12 | 14 |    |    |  |
|                   | 1.50               | 015           | 3                                   | 4    | 5   | 6 | 8 | 10 | 12 | 14 | 16 | 18 |    |    |    |  |
|                   | 2.00               | 020           | 3                                   | 4    | 5   | 6 | 8 | 10 | 12 | 14 | 16 | 18 | 20 | 22 |    |  |
|                   | 2.50               | 025           | 3                                   | 4    | 5   | 6 | 8 | 10 | 12 | 14 | 16 | 18 | 20 | 22 |    |  |
|                   | 3.00               | 030           |                                     |      | 5   | 6 | 8 | 10 | 12 | 14 | 16 | 18 | 20 | 22 | 25 |  |
|                   | 4.00               | 040           |                                     |      |     |   |   | 10 | 12 | 14 | 16 | 18 | 20 | 22 | 25 |  |
|                   | 5.00               | 050           |                                     |      |     |   |   |    | 12 | 14 | 16 | 18 | 20 | 22 | 25 |  |
|                   | 6.00               | 060           |                                     |      |     |   |   |    |    | 14 | 16 | 18 | 20 | 22 | 25 |  |

### **i** Features and options

- Precision stainless steel dowel pin, suitable for accurate location and alignment
- Imperial sizes available
- Alternative materials available



# To suit 3 - 12 mm Shafts

# External Circlips

All dimensions in mm  
General tolerances  $\pm 0.13$  mm  
Material: Stainless steel

**Associated Products**  
Shafts: page 11-2  
Bearings: page 12-2

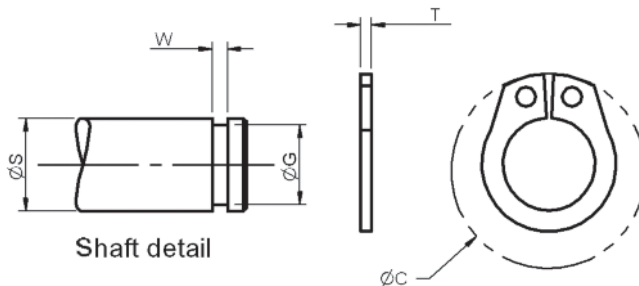

## Part number selection table

| Example Part No:- <b>D1400 - 0060 - SS</b> |                        |             |             |                    |         |        |           |
|--|------------------------|-------------|-------------|--------------------|---------|--------|-----------|
| Basic Part Number                          | Nominal Shaft Dia (ØS) | Dia Code    | Circlip     |                    | Groove  |        | Mati      |
|  |                        |             | Thickness T | Clearance Dia (ØC) | Width W | Dia ØG |           |
| <b>D1400</b>                               | 3                      | <b>0030</b> | 0.40        | 7.00               | 0.64    | 2.80   | <b>SS</b> |
|  |                        |             | 0.35        |                    | 0.50    | 2.76   |           |
|  | 4                      | <b>0040</b> | 0.40        | 8.60               | 0.64    | 3.80   |           |
|  |                        |             | 0.35        |                    | 0.50    | 3.75   |           |
|  | 5                      | <b>0050</b> | 0.60        | 10.30              | 0.84    | 4.80   |           |
|  |                        |             | 0.55        |                    | 0.70    | 4.75   |           |
|  | 6                      | <b>0060</b> | 0.70        | 11.70              | 0.94    | 5.70   |           |
| 0.65                                       |                        |             | 0.80        |                    | 5.65    |        |           |
| 8  | <b>0080</b>            | 0.80        | 14.70       | 1.04               | 7.60    |        |           |
|  |                        | 0.75        |             | 0.90               | 7.54    |        |           |
| 10   | <b>0100</b>            | 1.00        | 17.00       | 1.24               | 9.60    |        |           |
|  |                        | 0.94        |             | 1.10               | 9.54    |        |           |
| 12   | <b>0120</b>            | 1.00        | 19.00       | 1.24               | 11.50   |        |           |
|  |                        | 0.94        |             | 1.10               | 11.39   |        |           |

### **i** Features and options

- Used to axially secure components, such as bearings on shafts
- Imperial sizes available
- Alternative materials available



Associated Products  
Shafts: page 11-2  
Bearings: page 12-2

All dimensions in mm  
General tolerances  $\pm 0.13$  mm  
Material: Stainless steel

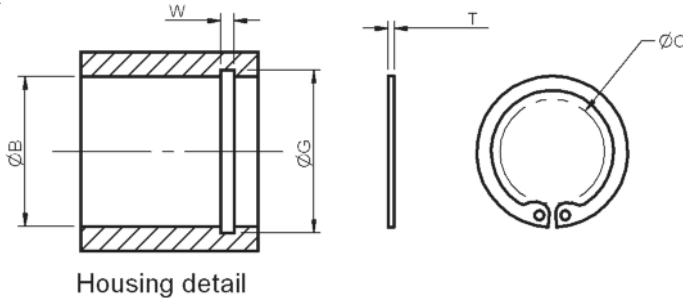

## Part number selection table

| Example Part No:- <b>D1300 - 0200 - SS</b> |                                      |             |             |                                   |         |                     |           |
|--|--------------------------------------|-------------|-------------|-----------------------------------|---------|---------------------|-----------|
| Basic Part Number                          | Nominal Bore Dia ( $\varnothing B$ ) | Dia Code    | Circlip     |                                   | Groove  |                     | Matl      |
|  |                                      |             | Thickness T | Clearance Dia ( $\varnothing C$ ) | Width W | Dia $\varnothing G$ |           |
| <b>D1300</b>                               | 12                                   | <b>0120</b> | 1.00        | 5.70                              | 1.24    | 12.61               | <b>SS</b> |
|  |                                      |             | 0.94        |                                   | 1.10    | 12.50               |           |
|  | 15                                   | <b>0150</b> | 1.00        | 8.30                              | 1.24    | 15.81               |           |
|  |                                      |             | 0.94        |                                   | 1.10    | 15.70               |           |
|  | 16                                   | <b>0160</b> | 1.00        | 9.20                              | 1.24    | 16.91               |           |
|  |                                      |             | 0.94        |                                   | 1.10    | 16.80               |           |
|  | 19                                   | <b>0190</b> | 1.00        | 11.80                             | 1.24    | 20.13               |           |
|  |                                      |             | 0.94        |                                   | 1.10    | 20.00               |           |
|  | 20                                   | <b>0200</b> | 1.00        | 12.60                             | 1.24    | 21.13               |           |
| 0.94                                       |                                      |             | 1.10        |                                   | 21.00   |                     |           |
| 22   | <b>0220</b>                          | 1.00        | 14.60       | 1.24                              | 23.13   |                     |           |
|  |                                      | 0.94        |             | 1.10                              | 23.00   |                     |           |
| 24   | <b>0240</b>                          | 1.20        | 16.40       | 1.44                              | 25.41   |                     |           |
|  |                                      | 1.14        |             | 1.30                              | 25.20   |                     |           |
| 28   | <b>0280</b>                          | 1.20        | 19.80       | 1.44                              | 29.61   |                     |           |
|  |                                      | 1.14        |             | 1.30                              | 29.40   |                     |           |
| 30   | <b>0300</b>                          | 1.20        | 21.80       | 1.44                              | 31.65   |                     |           |
|  |                                      | 1.14        |             | 1.30                              | 31.40   |                     |           |

### **i** Features and options

- Used to axially secure components, such as bearings in housings
- Imperial sizes available
- Alternative materials available

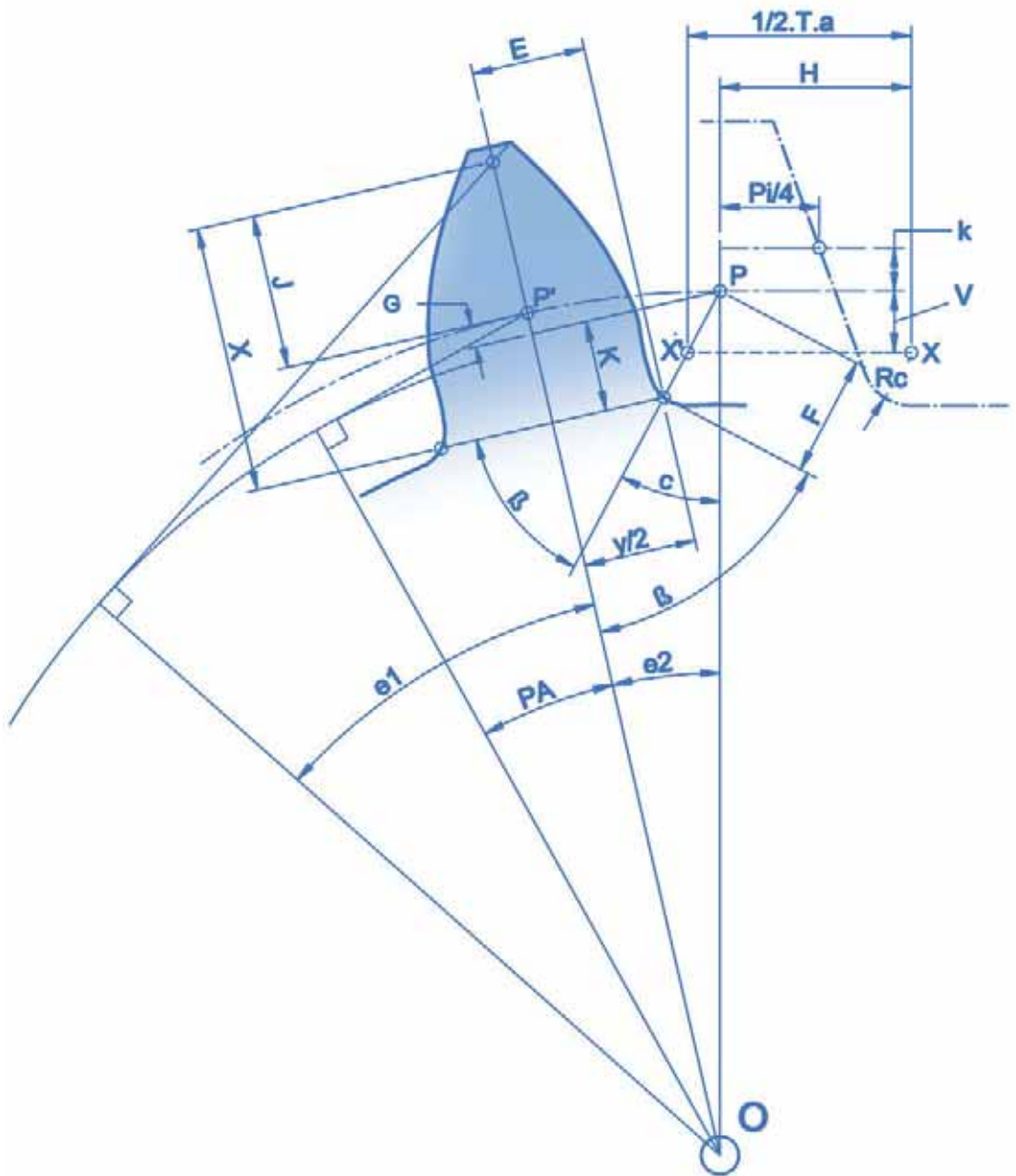

# Section Contents

- Conversion Factors .....Page T-2
- Contents .....Page T-3
- Technical Information
  - Stepper Motors .....Page T2-1
  - Gearboxes .....Page T3-1
  - Gears, Worms and Wheels .....Page T4-1
  - Racks and Pinions .....Page T6-1
  - Leadscrews and Nut Assemblies .....Page T7-1
  - Couplings .....Page T8-1
  - Linear Guides and Slides.....Page T9-1
  - Belts and Pulleys .....Page T10-1
  - Bearings and Spacers .....Page T12-1
  - Hardware .....Page T13-1



| Standard Conversion Factors |  |   |  |
|-----------------------------|--|---|--|
| <b>Length</b>               | 1mm = 0.03937 in   | 1in = 25.4 mm   |  |
| <b>Area</b>                 | 1mm <sup>2</sup> = 0.00155 in <sup>2</sup>   | 1in <sup>2</sup> = 645.16 mm <sup>2</sup>   |  |
| <b>Volume</b>               | 1mm <sup>3</sup> = 61.02 x 10 <sup>-6</sup> in <sup>3</sup><br>1 litre = 1 x 10 <sup>6</sup> mm <sup>3</sup>   | 1in <sup>3</sup> = 16387 mm <sup>3</sup><br>1ml = 1 cm <sup>3</sup>   |  |
| <b>Force and mass</b>       | 1N = 0.101972 kgf<br>1kgf = 9.80665 N<br>1kg = 2.2046 lb   | 1lbf = 4.4482 N<br>1N = 0.2248 lbf<br>1lb = 0.4536 kg   |  |
| <b>Torque</b>               | 1Nm = 8.8507 lbfin<br>1Nm = 141.612 ozfin<br>1Nm = 10197.16 gfcM   | 1lbfin = 0.1130 Nm<br>1ozin = 0.00706 Nm  |  |
| <b>Power</b>                | 1kW = 1.360 PS (metric hp)<br>1kW = 1.341 hp   | 1hp = 0.7457 kW   |  |
| <b>Moment of inertia</b>    | 1kgm <sup>2</sup> = 54674.75 ozins <sup>2</sup><br>1gcm <sup>2</sup> = 5.467 x 10 <sup>-3</sup> ozin <sup>2</sup><br>1kgm <sup>2</sup> = 23.73 lbft <sup>2</sup> | 1ozins <sup>2</sup> = 18.29 x 10 <sup>-6</sup> kgm <sup>2</sup><br>1ozin <sup>2</sup> = 182.9 gcm <sup>2</sup><br>1lb.ft <sup>2</sup> = 0.0421 kgm <sup>2</sup> |  |
| <b>Pressure and stress</b>  | 1N/m <sup>2</sup> = 145 x 10 <sup>-6</sup> lbf/in <sup>2</sup><br>1N/m <sup>2</sup> = 64.75 x 10 <sup>-9</sup> tonf/in <sup>2</sup>                              | 1lbf/in <sup>2</sup> = 6.895 x 10 <sup>3</sup> N/m <sup>2</sup><br>1tonf/in <sup>2</sup> = 15.44 x 10 <sup>6</sup> N/m <sup>2</sup>                             |  |
| <b>Temperature</b>          | °C = (°F-32)*5/9<br>K = °C+273.15  | °F = (°C*9/5)+32<br>°R = °F+459.67  |  |
| <b>Angles</b>               | 1rad = 180/π degrees<br>1mrad = 10.8/π arcmins   | 1 degree = π/180 rad<br>1 arcmin = π/10.8 mrad  |  |

| S.I. Multiples |        |                   |
|----------------|--------|-------------------|
| Prefix name    | Symbol | Factor            |
| tera           | T      | 10 <sup>12</sup>  |
| giga           | G      | 10 <sup>9</sup>   |
| mega           | M      | 10 <sup>6</sup>   |
| kilo           | k      | 10 <sup>3</sup>   |
| hecto          | h      | 10 <sup>2</sup>   |
| deca           | da     | 10 <sup>1</sup>   |
| deci           | d      | 10 <sup>-1</sup>  |
| centi          | c      | 10 <sup>-2</sup>  |
| milli          | m      | 10 <sup>-3</sup>  |
| micro          | μ      | 10 <sup>-6</sup>  |
| nano           | n      | 10 <sup>-9</sup>  |
| pico           | p      | 10 <sup>-12</sup> |
| femto          | f      | 10 <sup>-15</sup> |
| atto           | a      | 10 <sup>-18</sup> |

| Angular Resolution |         |          |           |
|--------------------|---------|----------|-----------|
| Bits               | Counts  | arcmins  | mrads     |
| 7                  | 128     | 168.75   | 49.087    |
| 8                  | 256     | 84.375   | 24.544    |
| 9                  | 512     | 42.188   | 12.272    |
| 10                 | 1024    | 21.094   | 6.1359    |
| 11                 | 2048    | 10.547   | 3.0680    |
| 12                 | 4096    | 5.2734   | 1.5340    |
| 13                 | 8192    | 2.6367   | 0.76699   |
| 14                 | 16384   | 1.3184   | 0.38350   |
| 15                 | 32768   | 0.65918  | 0.19175   |
| 16                 | 65536   | 0.32959  | 0.095874  |
| 17                 | 131072  | 0.16479  | 0.047937  |
| 18                 | 262144  | 0.082397 | 0.023968  |
| 19                 | 524288  | 0.041199 | 0.011984  |
| 20                 | 1048576 | 0.020599 | 0.0059921 |





|  |            |
|--|------------|
| Intelligent motors and rack actuators                    |            |
| Reliance Cool Muscle features .....                      | Page T2-1  |
| Rack actuators - Cool Muscle motors .....                | Page T2-5  |
| Rack actuators - Stepper motors .....                    | Page T2-6  |
| Gearboxes  |            |
| Planetary gearbox engineering data .....                 | Page T3-1  |
| Planetary gearbox installation .....                     | Page T3-2  |
| Epicyclic module torque curves .....                     | Page T3-4  |
| Epicyclic requirements for assembling units .....        | Page T3-5  |
| Epicyclic notes for handling .....                       | Page T3-6  |
| Standard gear range                                      |            |
| Gear tolerances .....                                    | Page T4-1  |
| Materials and specifications .....                       | Page T4-4  |
| Geometry and equations .....                             | Page T4-5  |
| Gears with small numbers of teeth .....                  | Page T4-8  |
| Engineering data .....                                   | Page T4-9  |
| Backlash for standard gears .....                        | Page T4-17 |
| Worm and wheels formulae .....                           | Page T4-18 |
| Racks and pinions  |            |
| Rack manufacture, standards and tolerances .....         | Page T6-1  |
| Engineering data .....                                   | Page T6-2  |
| Installation .....                                       | Page T6-4  |
| Rack applications .....                                  | Page T6-6  |
| Leadscrew and nut assemblies                             |            |
| Features .....   | Page T7-1  |
| Engineering data .....                                   | Page T7-2  |
| TFE coated assemblies .....                              | Page T7-5  |
| Couplings  |            |
| Performance .....  | Page T8-1  |
| Transmission error .....                                 | Page T8-2  |
| Torsional resonance .....                                | Page T8-3  |
| Installation .....                                       | Page T8-3  |
| Linear products - slides                                 |            |
| Features .....   | Page T9-4  |
| Engineering data .....                                   | Page T9-4  |
| RST miniature stroke slides rated life calculation ..... | Page T9-4  |
| Engineering data - Miniature linear guides .....         | Page T9-4  |
| Belts and pulleys  |            |
| Engineering data .....                                   | Page T10-1 |
| Bearings and spacers                                     |            |
| Gear mesh reactions .....                                | Page T12-1 |
| Force sharing and bearing life .....                     | Page T12-3 |
| Installation .....                                       | Page T12-4 |
| Hardware   |            |
| Limits and tolerances .....                              | Page T13-1 |



## RELIANCE COOL MUSCLE FEATURES

The Reliance Cool Muscle (RCM) is packed with features that help you reduce the size and cost of your machine while reducing development time.

### Simple and Compact

An intelligent driver with a 32 bit CPU based motion controller, driver amplifier, magnetic encoder and power management are all built on to the motor.

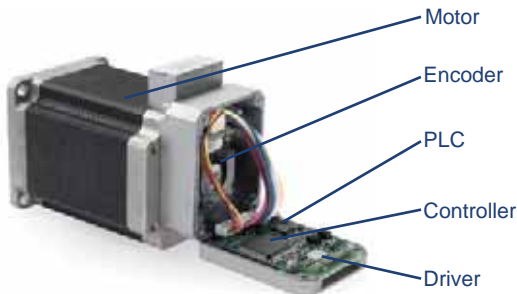

## FULL CLOSED LOOP SYSTEM

RCM is a fully closed loop system. With a high resolution magnetic encoder and the intelligent driver board mounted on the back, RCM constantly monitors every aspect of its operation, eliminating any missed steps.

### Closed Loop System

By receiving position input from the sensor, the RCM knows its position and can correct itself.

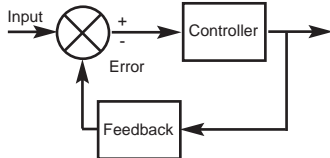

### H-Infinity

Using the newest control technology, the RCM goes beyond static PID control by utilising the robust  $H_{\infty}$  control system.  $H_{\infty}$  responds to dynamic loads across the entire speed range, reduces the need to tune gains and increases the allowable inertia mismatch.

## SMOOTH AND ACCURATE MOVEMENTS

The RCM's high resolution encoder gives you exceptionally fine positioning of 50,000 units per rotation. The RCM uses Vector Drive Control to produce extremely smooth motion, even at low speeds, not possible with micro-stepping drivers.

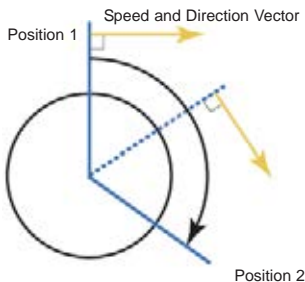

### Vector Drive Control

Vector Drive is a control technique used in servo systems; it is a completely different technique from micro-stepping. Unlike micro-stepping, Vector Drive Control is not subject to resonance problems, produces smooth movements, increases torque and increases efficiency.



### COOL OPERATION

RCM's power management monitors and provides the optimum current based on load, keeping the motor cool. In addition, the RCM generates high torque at low speeds.

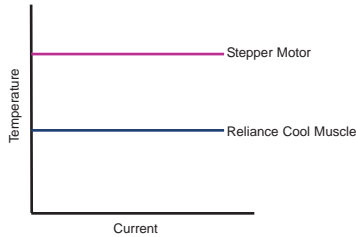

RCM applies optimum current to produce motion, whereas an open loop stepper always uses maximum current.

RCM has high torque even at low speeds and excels at both smooth motion and slow speeds.

RCM only draws power for what it needs, making the RCM power efficient and increasing motor life.

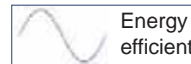

### CONTROL

P-type RCM is a drop-in step loss free replacement for a step/direction or CW/CCW pulse drive.

C-type RCM takes ASCII commands or MODBUS RTU from your PC, PLC or can use analogue (joystick) control.

|                   | Control  | Variations   |
|-------------------|--|--|
| <b>P Type</b><br> | Pulses   | CW/CCW<br>Step/Direction                               |
| <b>C Type</b><br> | PC<br>Embedded Computer<br>PLC<br>Switch<br>Analogue Input | Pre-programmed<br>Dynamic Command<br>Position<br>Speed |

### FULLY USER PROGRAMMABLE

Program the RCM to create the motion you need. Define motion profiles and create programs using easy-to-understand RCM Language (RCML). Motion programs you create can be downloaded to the RCM. The programs can be executed via PC, embedded computer or simply using hardware inputs.

### RCML

Reliance Cool Muscle Language allows easy creation of motion programs. Programs can be downloaded to the RCM using free Control Room software available from:

[www.reliance.co.uk/en/downloads-motors-and-cables](http://www.reliance.co.uk/en/downloads-motors-and-cables)

**P1=1000**  
**P2=2000**  
**S1=200**  
**S2=300**  
**A1=50**  
**A2=150**  
**T1=20**

Define motion profiles such as speed, acceleration position and timer.

**B1**  
**A1,S1,P1**  
**S2,P2,P1**  
**C2**  
**B2**  
**A2,S1,P3**

Define motion programs using the motion parameters defined above.



## USER DEFINABLE PARAMETERS

Define the character of your RCM to suit your needs. The RCM gives you over 60 parameters which can easily be set using RCML.

|                   |       |  |
|-------------------|-------|--|
| <b>K48=10000</b>  | ••••• | Origin offset distance set to 10000 pulses.      |
| <b>K58=200000</b> | ••••• | Software limit + side set to 200000 pulses.      |
| <b>K37=3</b>      | ••••• | Motor resolution set to 1000.                    |
| <b>K46=1</b>      | ••••• | Automatic home routine using mechanical stopper. |
| <b>K38=0</b>      | ••••• | Sets analogue interface to speed control mode.   |

## PARAMETER EXAMPLES:

### Home Search Method

The home search parameter lets you select a home search method. Home position can be determined using a hard-stop/bumper instead of a home switch. The RCM hits a bumper at low speed and torque and keeps pushing until it reaches a specified current level at which the motor determines that it has reached home. This method eliminates the need for a home switch and wiring.

### Software Limit

Set software limits using RCM parameters. Set limits on both CW and CCW sides, to eliminate switches.

These two software features will save you the cost of three sensors and the time needed to install wiring and calibrate them.

## SOFTWARE INTERFACE

### Serial Protocol

The PC interface to the Cool Muscle 'Y' Cable is RS232. Cool Muscle serial communications use the ASCII character set. Characters are transmitted with 8 data bits, no parity bit, and one stop bit. There is no hardware or software flow control. The baud rate is selectable from 9600, 19200, 38400 (default) and 57600 baud. The command separator is carriage return or comma. Line feeds are optional and are ignored.

### Register Model

The data memory of the Cool Muscle is divided into families of registers. Each register is labelled by its family (letter) and register number. General parameters and settings are in the K-family. For example register K58 holds the software limit for maximum travel in the + direction in units of 1000 steps. To read the limit, simply send the register name K58 to the motor and it will respond with K58.1=247 if the limit is 247000 steps. To change the limit to 352000 steps, send command K58=352. The K-parameters are non-volatile. If multiple motors are daisy chained together it is necessary to add the motor number to the command, so K58.2 refers to register K58 in motor 2. Each motor can store 25 positions in P-registers P1 to P25, fifteen speeds in S1 to S15, and so on. There are registers for eight accelerations, seven maximum torques, eight dwell timers, and fifteen unassigned registers for general use. M6.4 is torque limit register number six in motor 4, for example. These registers are volatile, but can be saved into the Cool Muscle controller's EEPROM. The saved values are automatically reloaded into RAM when the motor is switched on.

Technical Information



### Program Banks

Up to 15 programs can be stored in the controller EEPROM. Each is a sequence of commands.

```
B2.5           This is program 2 in motor 5
A3.5,S5.5,M1.5 Load motion parameters from registers
F2.5           Reset OUTPUT 2
X7.5           Start of loop, loop 7 times
  P1.5         Go to position in register P1
  T1.5         Dwell for time in register T1
  P2.5         Go to position in register P2
  T1.5         Dwell for time in register T1
X.5-           End of loop
C3.5           Call program B3.5 as a subroutine
O2.5           Assert OUTPUT 2
END.5          End of program
$.5            Save to EEPROM, motor 5
```

This program can be started by sending the short command [2.5.

### Logic Banks (PLC Function)

Logic banks are similar to bank programs but are run periodically with a maximum frequency of once every 1ms.

```
L1.1           This is logic bank 1 in motor 1
I3.1,J2.1      Test INPUT 3, if set jump to bank 2
END.1

L2.1           Logic bank 2
S.1=S2.1       Load speed from register S2
A.1=A1.1       Load acceleration from register A1
^.1            Activate new speed and acceleration
J3.1           Jump to bank 3
END.1

L3.1           Logic bank 3
I3.1,T0.1,J4.1 Test INPUT 3, if set ignore (T0.1)
END.1           Otherwise jump to bank 4

L4.1           Logic bank 2
S.1=S3.1       Load speed from register S3
^.1            Activate new speed
J1.1           Jump to bank 1
END.1

$.1            Save to EEPROM, motor 1
```

Execution starts in logic bank L1.1. If INPUT 3 is not set, nothing happens until the next periodic run. Then L1.1 runs again.

If INPUT 3 is ever set, a jump occurs. Logic bank L2.1 makes a speed change and control jumps immediately to logic bank L3.1.



Control now remains with L3.1 until INPUT 3 is reset. Then L4.1 makes another speed change and control goes back to the beginning.

The effect is that motor speed is selected using INPUT 3. The speed change is smooth, using the acceleration in register A1.1 and S-curve shaping if parameter K69 is set.

Bank programs and logic banks can both run at the same time, so an ordinary bank program can initiate a motor move and then a logic bank can modify the speed en route.

### More Information

A quick reference card listing all registers and commands is on our website, together with a more detailed programming manual: [www.reliance.co.uk/en/downloads-motors-and-cables](http://www.reliance.co.uk/en/downloads-motors-and-cables)

## ELECTRICAL INTERFACE

The RCM has 4 inputs and 2 outputs that can be used as digital, analogue, serial or pulse counter (input only). RCM lets you assign a different function to each edge and level of a signal.

### Pin Layout

| Pin # |             |                                    |            |
|-------|-------------|------------------------------------|------------|
| 1     | +24 V DC IN | Motor power                        | +24 V±10%  |
| 2     | 0V          | Power ground                       | Note 7     |
| 3     | INPUT 2-    | Return for pin 9                   | Notes 2, 8 |
| 4     | OUTPUT 2+   | Digital/analogue output, serial Tx | Note 5     |
| 5     | OUTPUT 1+   | Digital/analogue output, serial Tx | Notes 1, 5 |
| 6     | INPUT 4+    | Digital/analogue input             | Notes 3, 4 |
| 7     | INPUT 3+    | Digital input                      | Note 3     |
| 8     | INPUT 1-    | Return for pin 10                  | Notes 1, 8 |
| 9     | INPUT 2+    | Digital/counter input, serial Rx   | Notes 2, 8 |
| 10    | INPUT 1+    | Digital/counter input, serial Rx   | Notes 1, 8 |
| 11    | 0V          | Signal ground                      | Note 7     |
| 12    | +5V DC OUT  | Power out                          | Note 8     |

### Notes

1. Normally used for serial communication with the host PC via an accessory 'Y' or USB cable. In a daisy chain system with multiple motors, used for serial communication with the next upstream, slave or master motor. If the Cool Muscle is being used stand-alone INPUT 1 and OUTPUT 1 can be assigned other functions. These functions are activated when the 'Y' Cable is detached (power off before disconnecting).
2. In a daisy chain system with multiple motors, used for serial communication with the next downstream, slave motor. Otherwise INPUT 2 and OUTPUT 2 can be assigned other functions.
3. When programmed as a digital input, INPUT 3 and INPUT 4 logic levels are:-  
HIGH > +3 V (minimum 7 mA)  
LOW < +0.8 V
4. Analogue input range is 0 V to +4.8 V. Resolution is 10-bit (0 – 1023).
5. When programmed as a digital output this signal is NPN, open collector. When programmed as an analogue output the signal range is 0V to 5V. Resolution is 8-bit (0 – 255).
6. Total output current maximum 50 mA.
7. Pins 2 and 11 are internally connected.
8. When used for STEP/DIRECTION pulse control, INPUT 1 is the step input and INPUT 2 is the direction input. When used for CW/CCW pulse control INPUT 1 steps the motor clockwise and



INPUT 2 steps anti-clockwise.  
 Maximum pulse frequency: 500 K pulse/s  
 Minimum pulse width; 0.8  $\mu$ s  
 Pulse level high > +3 V (minimum 7 mA)  
 Pulse level low < +0.8 V

### Wiring for INPUT 1 and INPUT 2

These inputs are opto-isolated inputs, minimum 5 V, maximum 24 V. Examples:-

Input 1

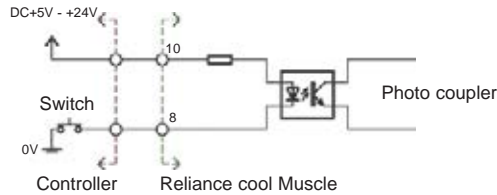

Input 2

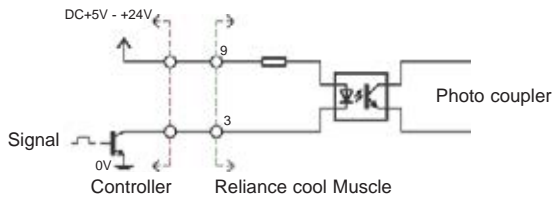

### Wiring for INPUT 3 and INPUT 4

These inputs are internally pulled up to +5 V. To operate them connect to 0 V through a switch or open collector (NPN) output. Examples:-

Input 3

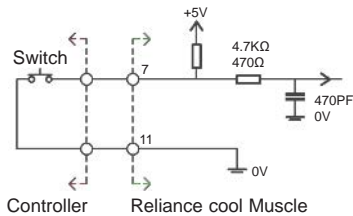

Input 4

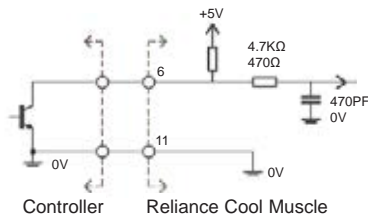

Technical  
Information



## Wiring for OUTPUT 1 and OUTPUT 2

Outputs 1 & 2 can work across a range of voltages from 5 V to 24 V. The collector current of the transistor must be limited to a maximum of 100mA.

### Output 1

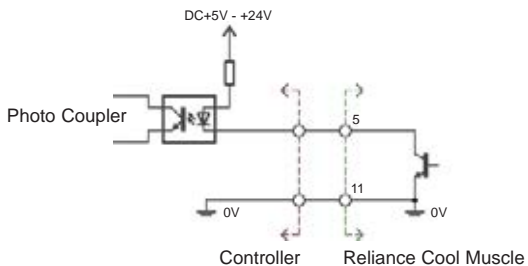

### Output 2

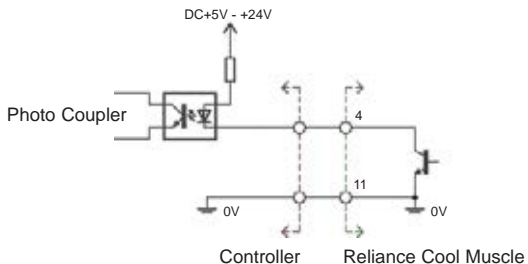

## ADVANCED MOTION

Speeds and accelerations can be changed whilst the motor is in operation. RCM supports a range of advanced motion features such as PTP motion incorporating changing accelerations and variable torque control. The powerful push mode is also standard allowing for electric emulation of common pneumatic operations.



**Continuous PTP:** There are no stops in motion between origin and P3. Speed and acceleration are changed at each point.



**Push Mode:** Mimics a typical pneumatic motion. It keeps pushing for a given time and at a set current level when a motor encounters a resistance such as a bumper or stopper.





### NETWORK

RCM provides you with different networking solutions to suit your needs. When multiple RCMs are connected in a daisy chain network, any RCM can tell other motors to activate programs as well as receive commands from a computer or embedded controller. In fact, after programming, RCMs can operate without any PC, PLC or HMI control.

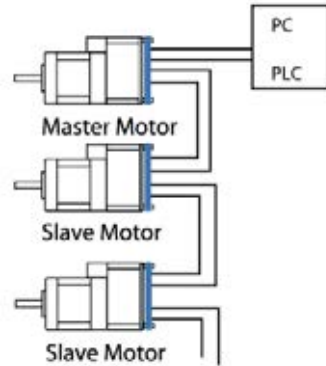

### TORQUE CONTROL AND FEEDBACK

The RCM controller uses the integrated current and position sensors to maintain sophisticated torque control during motion operation. Peak running torque can be easily set within motion programs, or the built in Push Mode function can be quickly implemented to mimic pneumatic cylinder operations.

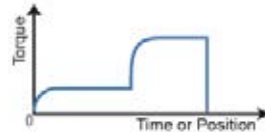

### 2-AXIS CO-ORDINATED MOTION

The RCM servo provides 2 axes contouring utilizing a 2+ motor daisy chain network. Additional linear axes can be implemented on the same motor for applications such as dispensing, cutting, or inspection. Programs can be run directly from the motor without the need for a host controller, or can be streamed from a PC for greater flexibility.



### LOGIC PROGRAMMING AND PLC FUNCTIONALITY

The RCM real time operating system precisely controls I/O timing allowing for PLC style I/O operation. Logic banks provide a flexible logical and mathematical capability analogous to that offered by traditional ladder logic. User defined actions can be triggered by external inputs or by internal motor conditions such as speed, torque, or position.



## RACK ACTUATOR

### Installation

Each Racktuator™ is supplied pre-assembled with carefully set clearances and alignments. Disassembly may result in reduced performance and accuracy. The rack should not be removed from the housing to avoid possible damage to teeth when it is re-inserted.

### Axial load rating

The axial load rating is dependent upon the rack, pinion and motor. As a general guide the load ratings in the product data pages (see [pages 2-15 to 2-17](#)) can be used to determine the allowable rack thrust.

### Basic Ratings:

- For axial thrust loads of up to 3 N use a RCMRA17-6-250 tubular rack (see [page 2-15](#)) with a PEEK pinion
- For axial thrust loads from 3 N to 20 N use a stainless steel pinion in lieu of PEEK pinion
- For axial thrust loads from 20 N to 90 N use the RCMRA23L (see [page 2-16](#)), which utilises a 17-4 PH stainless steel pinion and hardened stainless steel rack

### Position accuracy and side wobble

Positioning accuracy depends on the resolution of the motor and the drive system. For the RRA series the full step size of the motor is 1.8° which translates to 0.2 mm of linear motion of the rack. Finer positioning may be achievable with a half-stepping or micro-stepping drive. For the RCMRA series where the angular resolution is 0.0072° the linear resolution is 0.0008 mm, depending on load and dynamic conditions.

Side wobble is dependent upon initial clearance between rack and bearing bore, the length of rack and wear between the rack and plain bearings. For RRA17-6-250 (see [page 2-15](#)) the maximum side wobble is  $\pm 0.2$  mm at end of the rack with maximum protrusion from the housing.

### Backlash

This is currently set on assembly between 0.020 mm and 0.060 mm axial clearance of the rack. It is possible to improve this on assembly and also reduce the rotation of the rack in the clearance, please contact us. It is not advisable to reduce backlash to zero as pinion eccentricities and temperature variations could cause binding. A temperature rise of approx. 35°C would be needed to cause possible binding of rack and pinion when a backlash of 0.010 mm is set.

### Lubrication

PEEK pinion and stainless steel racks require no lubrication. Stainless steel racks and pinions require a smear of a lithium based grease on to the rack teeth for periodic lubrication.



## RACKTUATOR™ STEPPER MOTORS

Stepper motors operate by rotating the motor shaft at discrete intervals ( $1.8^\circ$  for our steppers) as they receive electrical input pulses. This basic characteristic distinguishes stepper motors from other motors and makes them ideal for applications where accurate positioning and control is required, without the need for expensive feedback hardware.

### Features of stepper motors

- Position holding - (Detent torque)** - Even with no power applied to the windings, stepper motors will resist rotation, which may be useful in applications that would normally experience 'drift'. If power is applied, this holding torque is significant.
- High acceleration -** They have excellent acceleration performance that allows a start, stop and reverse to be performed at relatively high speed.
- Good reliability -** The only components subject to wear are the bearings, as there are no brushes or commutators.
- Low component count -** Stepper motors permit open-loop, high precision positioning control, therefore feedback hardware for control is not required, which leads to low cost system design.

### Drive methods

There are three main modes of driving a stepper motor - Full Step, Half Step and Micro Step. With Full Step, the angular movement is the basic step angle, ie  $1.8^\circ$ . By manipulating the energisation sequence applied to the motor, it is possible to reduce the basic step angle by half. By manipulating the shape of the pulses applied to the motor, as well as the energisation sequence, the basic step angle can be split into several hundred micro steps. This large increase in resolution can only be achieved by using more complex drive electronics.

There are a number of methods of driving stepper motors, that basically divide into two groups; unipolar and bipolar drives. In unipolar drives the current always travels through the windings in the same direction. This is often achieved by attaching one end of each winding to a fixed voltage supply rail. With bipolar drives the current travels in both directions, which can give benefits in performance, although it usually requires more switching components. In both cases additional components such as resistors are often used to adapt a drive to a specific motor or to modify the characteristics of the motor-load system.

Our Racktuator™ stepper motors have 6 wires, which allow the user to choose between unipolar and bipolar drives. Steppers with less wires do not.

The design and implementation of a suitable drive for a specific application can be quite an involved process and is outside the scope of this technical section. For further advice please contact Reliance Technical Sales.



## Technical information

|                              |   |
|------------------------------|---|
| Insulation parameters        | Dielectric Strength: 500 VAC<br>Insulation Class: Class B |
| Insulation resistance        | 100 MΩ min. (at 500 V DC)                                 |
| Dielectric strength          | 500 V AC (1 minute)                                       |
| Operating temperature range  | -20°C to +50°C  |
| Permissible temperature rise | 80°C max. (resistance method)                             |

**Note:** Do not allow the surface temperature of the motor case to rise above 90°C during operation.

## Installation - connections

Size 17 steppers have 200mm cables with a EHR-6 connector (JST). Mating parts are available from RS components; top entry (stock no 515-1434) or side entry (stock no 515-1349).

## Installation - wiring diagram

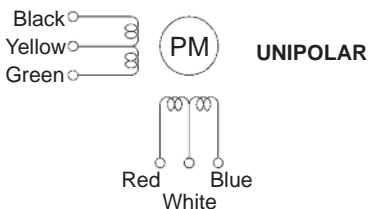

## CW rotation mounting end

| Step | Black | Red | Green | Blue | Yellow | White |
|------|-------|-----|-------|------|--------|-------|
| 0    | ON    | ON  |       |      | COM    | COM   |
| 1    |       | ON  | ON    |      | COM    | COM   |
| 2    |       |     | ON    | ON   | COM    | COM   |
| 3    | ON    |     |       | ON   | COM    | COM   |
| 0    | ON    | ON  |       |      | COM    | COM   |



### OUTPUT SHAFT BEARING LIFE

1. Calculate  $F_{rL}$  with the following formula

$$F_{rL} = \frac{F_a \times R + F_r \times (A + C_2)}{C_1}$$

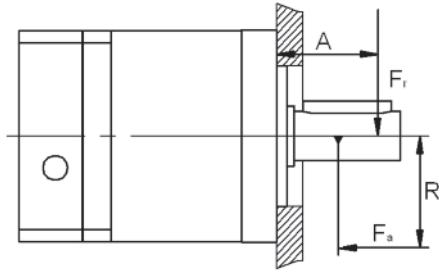

2. Calculate the force-proportion

$$e = \frac{F_a}{F_{rL}}$$

Please contact us if  $e > 0.22$

3. Calculate  $L_h$  with the following formula

$$L_h = \frac{16667}{n} \times \left( \frac{C_L}{F_{rL}} \right)^3$$

### FORMULA SYMBOLS

|       |                   |   |
|-------|-------------------|---|
| $L_h$ | h                 | lifetime                                      |
| $F_a$ | N                 | axial load at the output shaft                |
| $F_r$ | N                 | radial load at the output shaft               |
| R     | mm                | distance, axial load to centre of the gearbox |
| A     | mm                | distance, radial load to flange plane         |
| n     | min <sup>-1</sup> | output shaft speed                            |
| $C_x$ | -                 | gearbox constants from following table        |

|       |    | RGP40 | RGP60 | RGN70 |
|-------|----|-------|-------|-------|
| $C_1$ | mm | 10.5  | 11.5  | 13.5  |
| $C_2$ | mm | 12.9  | 15.5  | 23    |
| $C_L$ | N  | 2250  | 6050  | 9950  |

### MAXIMUM LOAD IN CENTRE OF THE OUTPUT SHAFT

|       |   | RGP40 | RGP60 | RGN70 |
|-------|---|-------|-------|-------|
| $F_r$ | N | 200   | 500   | 1000  |
| $F_a$ | N | 200   | 600   | 1200  |



## PLANETARY GEARBOX INSTALLATION MOUNTING

### RGP40 NEMA 17

Make sure the gearbox has the correct mounting features for the selected motor.

Clean the Cool Muscle and the RGP gearbox so they are grease free, make sure not to get cleaning fluid into either the motor or gearbox.

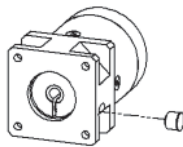
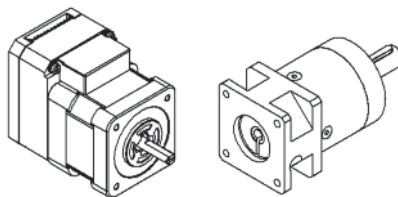

Remove the cover cap, adjust the position of the clamp to be in line with the mounting hole and open the clamp so that clamp diameter is greater than the motor shaft diameter.

The preferred method for mounting is in a vertical orientation as shown, mount the gearbox so it is flush with the motor, secure the gearbox and motor together with 4 off S-M3-8 screws and torque them up to  $T_{Mount}$  Nm.

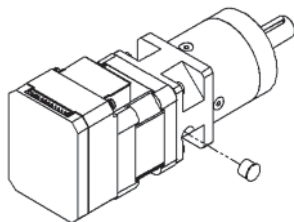
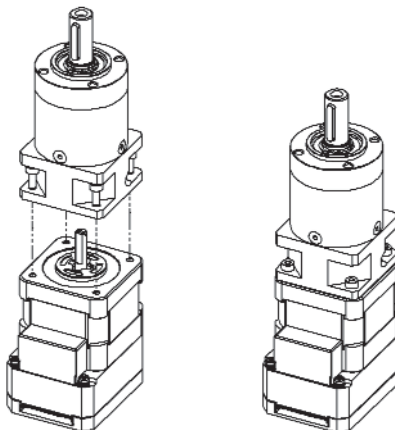

Tighten the clamp shaft onto the motor to  $T_{Clamp}$  Nm and re-attach cover cap.

| NEMA 17 Mounting Screw Torque    |        |
|----------------------------------|--------|
| Socket head cap screw order code | S-M3-8 |
| $T_{Clamp}$ (Nm)                 | 1.1    |



### RGP40, RGP60 and RGN70 NEMA 23

Make sure the gearbox has the correct mounting features for the selected motor.

Clean the Cool Muscle and the RGP gearbox so they are grease free, make sure not to get cleaning fluid into either the motor or gearbox.

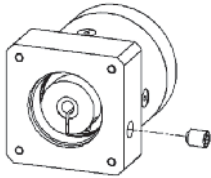
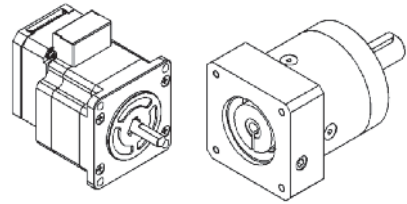

Remove the cover screw, adjust the position of the clamp to be in line with the mounting hole and open the clamp so that clamp diameter is greater than the motor shaft diameter

The preferred method for mounting is in a vertical orientation as shown, mount the gearbox so it is flush with the motor secure, bolt the two together with 4 off S-M4-12 screws and torque them up to  $T_{Mount}$  Nm.

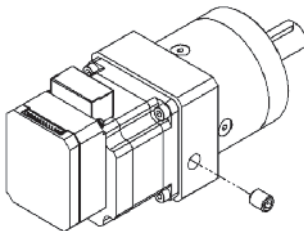
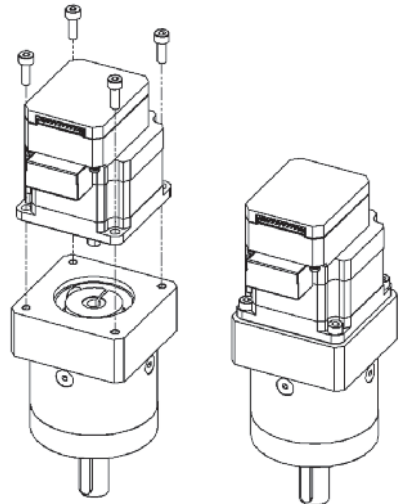

Tighten the clamp shaft onto the motor to  $T_{Clamp}$  Nm and re-attach cover screw.

| NEMA 23 Mounting Screw Torque    |         |
|----------------------------------|---------|
| Socket head cap screw order code | S-M4-12 |
| $T_{Clamp}$ (Nm)                 | 1.1     |

| Clamping Screw Torque          |     |     |     |
|--------------------------------|-----|-----|-----|
| Socket width across flats (mm) | 2   | 4.5 | 9.5 |
| $T_{Clamp}$ (Nm)               | 2.5 | 3   | 4   |

Technical Information



TORQUE CURVES

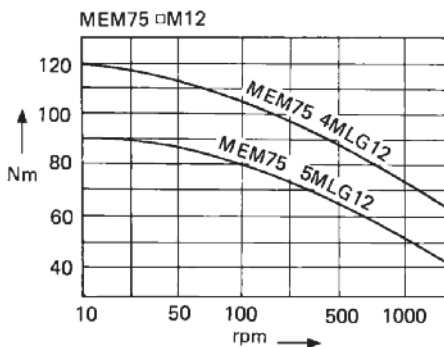
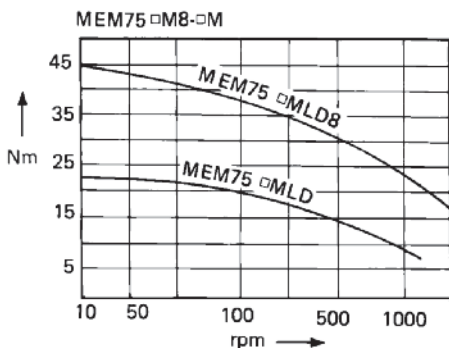
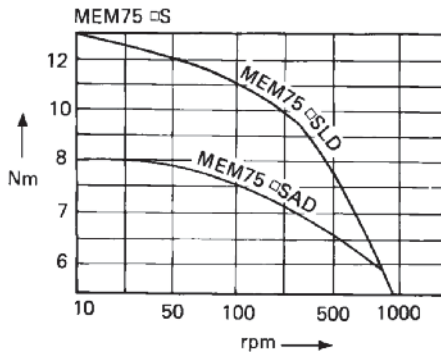
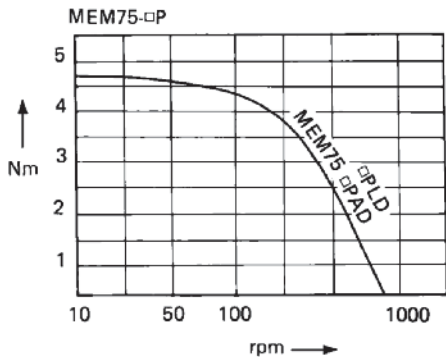

OUTPUT SHAFT TORQUE

This is derived from an eight hour day, continuous unidirectional drive and no impact fluctuating load.

PEAK TORQUE CAPABILITY

Momentarily allowable torque is 250% of rated torque (under the same conditions as output torque).

DYNAMIC LOAD FACTOR

The rated torque has been derated in accordance with the following table:

Dynamic Load Factor (Sf)

| Drive             | Driven<br>Hrs/day | Load Type     |                        |                       |
|-------------------|-------------------|---------------|------------------------|-----------------------|
|                   |                   | Uniform<br>Sf | Medium<br>Impact<br>Sf | Heavy<br>Impact<br>Sf |
| Electric<br>Motor | <3                | 1.0           | 1.0                    | 1.5                   |
|                   | 3 - 10            |               | 1.25                   | 1.75                  |
|                   | 24                |               | 1.5                    | 2.0                   |

$$\text{Allowable Torque} = \frac{\text{Rated Torque}}{Sf}$$





### REVERSING MOTION

Should MEMs be used in a reversing drive (eg. servo application) the units should be derated to 80%.

### TEMPERATURE RANGE

The unit will operate satisfactorily between  $-10^{\circ}$  and  $+65^{\circ}\text{C}$ . For the all metal units, maximum temperature is  $75^{\circ}\text{C}$ .

### MOUNTING POSITION

The standard position is horizontal. For other planes, please contact our sales team for more information.

### REQUIREMENTS FOR ASSEMBLING UNITS

- 1. Alignment** - Radial alignment errors, after fitting the input and output shafts, should be within 0.15mm.
- 2. Location of Internal Gear** - A unit should be located in the manner in which the torque distribution is uniform in the internal gear.
- 3. Clearance** - Axial clearance between the unit's revolving parts (Carrier A & B) and casing should be 2mm to 4mm.
- 4. Thrust Support when Mounting Vertically** - When mounting the units with shafts vertically, care must be taken to ensure that the mass of the module is supported by the shaft bearings and not the planet disks containing the internal gear. If the unit is mounted with the output shaft uppermost, then a shoulder will be required on the input shaft and vice versa.
- 5. Lubrication** - For grease lubrication the casing should be filled with grease to between 50% and 80% of the volume and for oil lubrication to between 30% and 50% of the volume.

### OVERHANG LOAD (OHL) - kg

The overhang load is a bending force acting on the shaft generated by external forces.

Calculate the OHL according to following equation and select an appropriate bearing:

$$\text{O.H.L. Capacity} = T \times E_f/R$$

T : Driving torque

R : Pitch circle radius of gear or sprocket

$E_f$  : Element factor:

|           |            |
|-----------|------------|
| Gear      | 1.1 - 1.25 |
| Sprocket  | 1.25       |
| Flat Belt | 2.5 - 3.0  |
| V Belt    | 1.5 - 2.0  |



## NOTES FOR HANDLING

1. Plastic Unit P - Lubricated with grease when assembled. (Units without grease lubrication are special to order).
2. Sintering Alloy Unit S - Not lubricated with grease when assembled. (Units with grease lubrication are special to order).
3. Metal Unit M - Not lubricated with grease or oil.
4. Do not mix strong acid or oil additives and thinners to the lubricant of the plastic units.
5. Do not allow rapid temperature variations. This will generate moisture.
6. Store the MEM units in a dark room below 40°C and keep in a dry, dust-free atmosphere.
7. If a unit is mounted on a surface which acts as a sounding-board, the noise will be amplified above the inherent noise level of the unit. Take care when mounting the unit.

## HOUSED UNITS (LGH)

MEM modules can be supplied mounted in an aluminium housing complete with output shaft and support bearings. The complete unit is rated at 10Nm output torque, and can have either one, two or three modules. Maximum reduction ratio is 125:1 with 3x5:1 ratio modules. The accompanying motor must have a 'D' shaped shaft of 8mm diameter and 7mm over the flat.

Also included is the MEM26. This is a housed unit complete with input and output shaft. Actual ratio is 91.125:1 and the unit is capable of handling 2 Nm output torque.

Larger modules are available up to 1000 Nm output torque. Please enquire.



## GEAR MANUFACTURE

Reliance's precision instrumentation gears are manufactured using high accuracy gearcutting equipment. Standard gears are produced in stainless steel, hardened stainless steel, aluminium alloy and brass (wormwheels only). Alternative materials such as PEEK polymer or Delrin are available on request.

## GEAR TOLERANCES

Gears are generally offered as Quality 10 (see the individual product pages). Higher qualities are available as shown in the table below. Most gears in the catalogue can be produced in these qualities to order.

Reliance standard tolerances are largely based on AGMA 390-03 backlash.

| Reliance Standard Gear Qualities |                |                       |                                |   |           |                   | Table values in 0.001mm (0.0001") |  |
|----------------------------------|----------------|-----------------------|--------------------------------|---|-----------|-------------------|-----------------------------------|--|
| Quality Class                    | Modular Range  | Total Composite Error | Tooth to Tooth Composite Error | Indicator Limits<br>Gauge zeroed at std. pitch rad. |           | Gear Quality Code |                                   |  |
|                                  |                |                       |                                | Max   | Min       |                   |                                   |  |
| AQ9                              | 1.5mod         | 26 (10)               | 18 (7)                         | -18 (-7)  | -69 (-27) | -                 |                                   |  |
| AQ10                             | 0.8 to 0.5 mod | 26 (10)               | 13 (5)                         | -18 (-7)  | -61 (-24) | -                 |                                   |  |
| AQ11                             |                | 18 (7)                | 10 (4)                         |   | -53 (-21) | C                 |                                   |  |
| AQ12                             |                | 13 (5)                | 8 (3)                          |   | -48 (-19) | B                 |                                   |  |
| AQ14                             |                | 7 (2.7)               | 3.6 (1.4)                      |   | -41 (-16) | A                 |                                   |  |
| AQ10                             | 0.4 to 0.2 mod | 26 (10)               | 13 (5)                         | -13 (-5)  | -51 (-20) | -                 |                                   |  |
| AQ11                             |                | 18 (7)                | 10 (4)                         |   | -43 (-17) | C                 |                                   |  |
| AQ12                             |                | 13 (5)                | 8 (3)                          |   | -38 (-15) | B                 |                                   |  |
| AQ14                             |                | 7 (2.7)               | 3.6 (1.4)                      |   | -33 (-13) | A                 |                                   |  |

Values in the above table refer to measurements obtained by means of the dual flank tester.

To specify a gear, other than the standard quality, add the quality code to the gear part number.

Example of a quality 12 gear - **P05S1B10F6A-100 B**

\_\_\_\_\_ Quality code

| Comparison of National Gear Quality Standards |                             |                                |                        |                   |           |                   |
|---|-----------------------------|--------------------------------|------------------------|-------------------|-----------|-------------------|
| Reliance Quality Class                        | American AGMA 390.03 (1980) | British BS. 4582 (pt.1 : 1970) | German DIN. 867 & 3963 | International ISO | Japan JIS | Admiralty BR.6001 |
| AQ9   | Q 9                         | Class C                        | Q 8                    | 8                 | 4         | Class 3           |
| AQ10  | Q 10                        | Class B                        | Q 7                    | 7                 | 3         | Class 2           |
| AQ11  | Q 11                        | Class A                        | Q 6                    | 6                 | 2         | Class 1           |
| AQ12  | Q 12                        | Class A                        | Q 5                    | 5                 | 1         | †                 |
| AQ14  | Q 14                        | †                              | Q 3                    | 3                 | 0         | †                 |

† Reliance quality higher than any equivalent in this specification.

Table applies to gears up to 50 mm diameter.



RELIANCE GEAR STANDARDS FOR FINE PITCH GEARS

The table below is a comparison between Reliance (AGMA) and equivalent UK specifications:

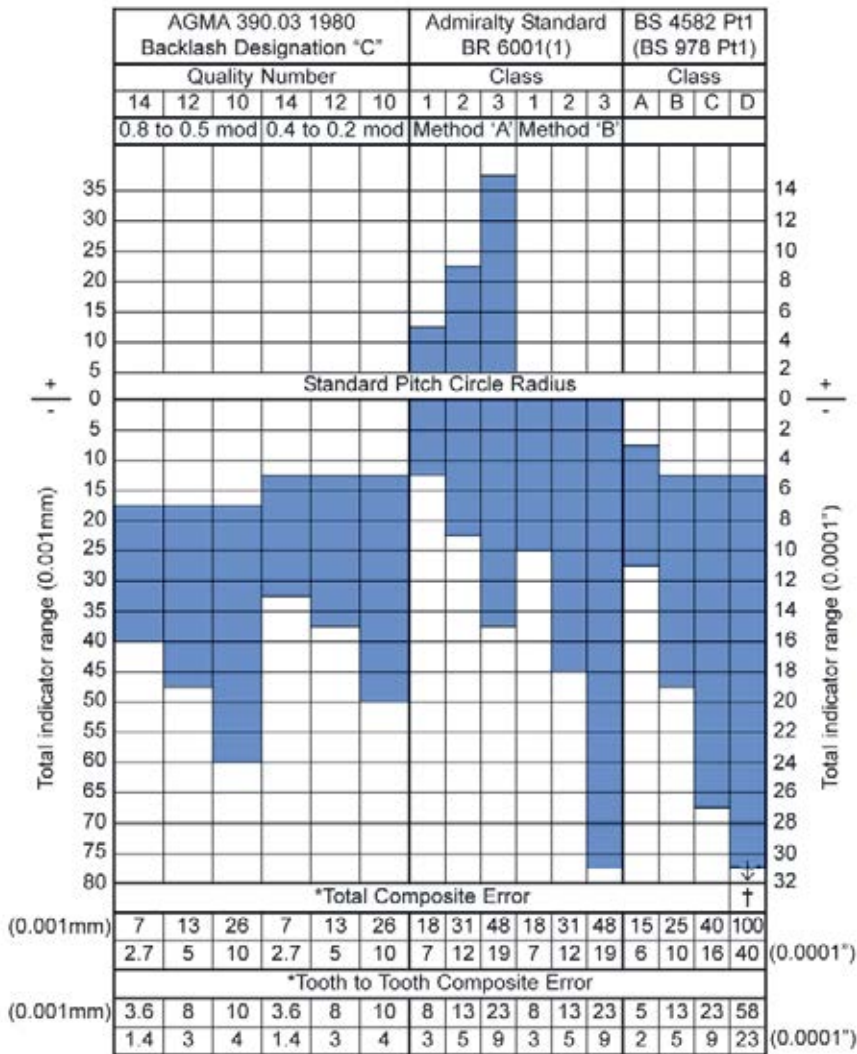

\*AGMA values quoted are for over 20T up to 50 mm (2") diameter. Admiralty and B.S. tooth to tooth errors are for over 30T.

† Minimum indicator level 0.006" or 0.15 mm.

For numbers of teeth outside the range consult the relevant specification.



### STANDARD MODULES AND CIRCULAR PITCHES - METRIC

Reliance's precision instrumentation spur gears are available as standard in the following modules and circular pitches, being those most commonly used in the design and manufacture of gear control mechanisms and instruments:

Module 0.2, 0.25, 0.3, 0.4, 0.5, 0.6, 0.8, 1.0, 1.25, 1.5  
Circular pitch 1, 2, 2.5, 3

#### Pressure Angle and Rack Form

Except where stated otherwise, gears in this catalogue are cut to 20° pressure angle involute form teeth. Reliance standard gears will mesh satisfactorily with gears of the same module cut to the following standards:

- (i) BS 4582 (1970) Part 1, Figure 1.
- (ii) DIN 867 and 58412.
- (iii) AGMA 207.06 (Assuming the pitch is cut to an equivalent module).

The gears will not mesh satisfactorily with gears cut to DIN 58400 unless the outside diameter of the latter is reduced to PCD + (2 x module).

DIN 58400 tooth proportions are:

Addendum      1.1 x Module  
Dedendum        1.5 x Module for pitch 0.1 to 0.6 Module

| Metric Tooth Proportions |                |          |          |               |             |                                 | (Dimensions in mm) |
|--------------------------|----------------|----------|----------|---------------|-------------|---------------------------------|--------------------|
| Module                   | Circular Pitch | Addendum | Dedendum | Working Depth | Whole Depth | Equivalent Inch Diametral Pitch |                    |
| 1.5                      | 4.712          | 1.5      | 1.875    | 3.0           | 3.375       | 16.933                          |                    |
| 1.25                     | 3.927          | 1.25     | 1.563    | 2.5           | 2.8125      | 20.320                          |                    |
| 1.0                      | 3.142          | 1.0      | 1.400    | 2.0           | 2.4         | 25.400                          |                    |
| 0.8                      | 2.513          | 0.8      | 1.120    | 1.6           | 1.92        | 31.750                          |                    |
| 0.6                      | 1.885          | 0.6      | 0.840    | 1.2           | 1.44        | 42.333                          |                    |
| 0.5                      | 1.571          | 0.5      | 0.700    | 1.0           | 1.2         | 50.800                          |                    |
| 0.4                      | 1.257          | 0.4      | 0.560    | 0.8           | 0.96        | 63.500                          |                    |
| 0.3                      | 0.942          | 0.3      | 0.420    | 0.6           | 0.72        | 84.667                          |                    |
| 0.25                     | 0.785          | 0.25     | 0.350    | 0.5           | 0.6         | 101.600                         |                    |
| 0.2                      | 0.628          | 0.2      | 0.280    | 0.4           | 0.48        | 127.000                         |                    |
| 0.318                    | 1.0            | 0.318    | 0.446    | 0.637         | 0.764       | 79.796                          |                    |
| 0.637                    | 2.0            | 0.637    | 0.891    | 1.273         | 1.528       | 39.898                          |                    |
| 0.796                    | 2.5            | 0.796    | 1.114    | 1.592         | 1.910       | 31.919                          |                    |
| 0.955                    | 3.0            | 0.955    | 1.337    | 1.910         | 2.292       | 26.599                          |                    |

The above list is by no means exhaustive. Please enquire if you require a special module as Reliance holds a large stock of non-standard cutters.



**MATERIALS AND SPECIFICATIONS**

Reliance's precision instrumentation gears are manufactured from the materials listed below. We reserve the right to change the actual material to an equivalent specification without notice depending on availability.

Technical  
Information

| Reliance Precision Gear Materials |  |         |   |               |
|-----------------------------------|--|---------|---|---------------|
| Material                          | Specification  |         | Used on   | Material Code |
| Stainless steel                   | 303S31 (303S21) or 303S42 (303S42) or 302S31 (302S25) or 303 to MIL QQ-S-764 | BS 970  | Pin hub gears<br>Clamp hub gears<br>Hubless gears<br>Worms<br>Gear clamp & hubs | S1            |
| Stainless steel                   | 316S31 (316S16)  | BS 970  | Rack pinions  | S2            |
| Stainless steel (hardened)        | 17-4PH1025<br>Hardened to 34-42 HRc  |         | Hardened pin hub gears  | S8            |
| Aluminium alloy                   | L168 or HE 15-TF or 2024-T4 to MIL QQ-A-225/6                                | BS 1474 | Pin hub gears<br>Clamp hub gears<br>Hubless gears<br>Gear clamp & hubs          | A1            |
| Phosphor bronze                   | PB 102   | BS 2874 | Worm wheels   | B1            |
| Brass                             | CZ121  | BS 2874 | Spur gears  | B2            |
| Brass (Naval)                     | Alloy 464 to MIL QQ-B-637  |         | Worm wheels   | B3            |
| Acetal                            | Delrin 150   |         | Hubless gears   | D1            |

**Finishes**

Stainless steel, bronze and brass gears remain in their natural condition. Passivation to DEF STAN 03-2, process M can be carried out if required. Aluminium components are anodised to specification DEF STAN 03-24 (chromic acid process) or DEF STAN 03-25 (sulphuric acid process). Gear teeth are not normally anodised.

**Anti-backlash Gears**

Materials and finishes of standard anti-backlash gear components.

Where possible circlips, anti-backlash springs, shims and set screws will be stainless steel. However, some smaller pinions may have beryllium copper or zinc plated carbon steel circlips as standard.



### SPUR GEAR GEOMETRY

A basic description of gear tooth terms is shown below. General formulae to enable correct understanding of spur gear geometry is shown opposite.

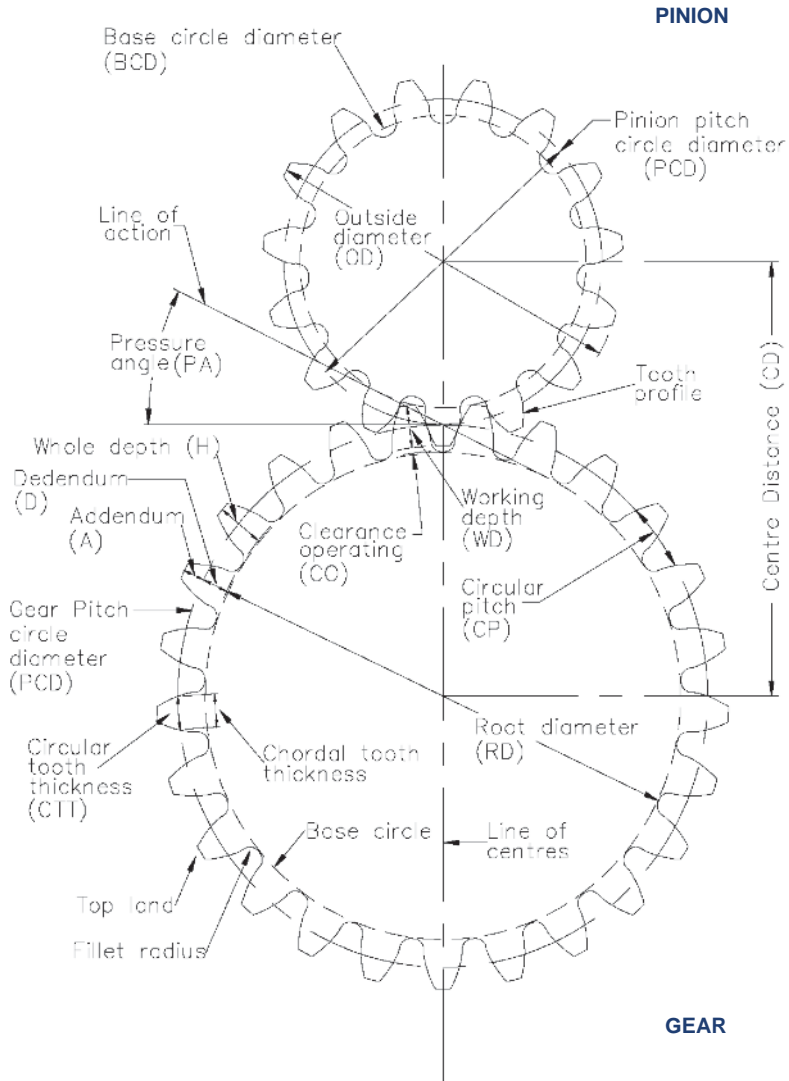



## TERMINOLOGY FOR METRIC SPUR GEARS

| TERM                           | DEFINITION  | FORMULAE                                   |
|--------------------------------|---|--|
| Addendum (A)                   | The radial distance between the pitch circle and the outside diameter.  | $A=M$                                      |
| Addendum modification (K)      | A method of modifying low tooth number gears to avoid undercutting and altering gear size to allow use of non standard centres. | See page T4-8                              |
| Backlash (B)                   | The circumferential clearance between mating gear teeth.  | See page T4-15                             |
| Base circle diameter (BCD)     | The diameter of the base cylinder from which the involute is generated.   | $BCD = N \cdot M \cos PA$                  |
| Base pitch (BP)                | The pitch along the base circle or line of action.  | $BP = \pi M \cos PA$                       |
| Basic rack                     | The straight sided rack shape from which teeth are generated.   | See BS 4582.                               |
| Centre distance (CD)           | Distance between the axes of rotation of mating spur gears.   | $CD = \frac{PCD_{pinion} + PCD_{gear}}{2}$ |
| Circular pitch (CP)            | The distance along the pitch circle between corresponding points on adjacent teeth.   | $CP = \pi M$                               |
| Circular tooth thickness (CTT) | The distance between opposite faces on the same tooth measured at the pitch circle diameter.                                    | $CTT = \frac{\pi M}{2}$                    |
| Clearance operating (CO)       | The amount by which the dedendum in a given gear exceeds the addendum of the mating gear.                                       | $CO = D - A$                               |
| Dedendum (D)                   | The radial distance between the pitch circle and the root diameter.   | $D = 1.4M$ (BS4582)<br>$= 1.25M$ (BS436)   |
| Diametral pitch (DP)           | The size of the tooth expressed in teeth per inch of pitch diameter.  |  |
| Face width                     | The width of the tooth in an axial plane.   |  |
| Fillet radius                  | The radius of the fillet curve at the base of the gear tooth.   |  |
| Length of action               | The distance on an involute line of action through which the point of contact moves during the action of the tooth profiles.    |  |





|                                       |  |   |
|---------------------------------------|--|---|
| Indicator limits                      | The size band of manufacture for the gear measured radially from the PCD.  |   |
| Module (M)                            | The size of the tooth expressed in mm of pitch diameter.   |   |
| Number of teeth (N)                   | Number of teeth on the gear.   |   |
| Outside diameter (OD)                 | The diameter over the tops of the teeth.   | $OD = PCD + (2M)$   |
| Pitch circle diameter (PCD)           | An imaginary circle whose diameter is formed by meshing gears so that the circles actually touch each other, as if gears were driven purely by the friction of the circles.                      | $PCD = (N+2K) \cdot M$<br>Note: for unmodified gears<br>$K=0$ |
| Pressure angle (PA)                   | The angle between a line tangential to the pitch circles and a line perpendicular to the tooth profiles at the point of contact. (Equal to the side angle of the basic rack for standard gears). | Standard = $20^\circ$   |
| Root diameter (RD)                    | The diameter of the base of the teeth.   | $RD = OD - (2H)$  |
| Total composite error (TCE)           | The total error in the gear measured by the dual flank gear test. TTCE and pitch line runout are included.   |   |
| Tooth to tooth composite error (TTCE) | The change in error of each tooth on the gear measured by the dual flank tester.   |   |
| Undercut                              | The loss of profile in the vicinity of the involute start at the base circle due to tool cutter action generating gears with low tooth numbers.<br>( $N_{min}$ = minimum teeth for no undercut)  | $N_{min} = \frac{2}{\sin^2 PA}$                               |
| Whole depth (H)                       | The total depth of a tooth space.  | $H = A + D$   |
| Working depth (WD)                    | The depth of engagement between mating gear teeth.   | $WD = 2A$   |

Note: for imperial gears to BS 978 Part 1, Equivalent Module =  $\frac{25.4}{DP}$

## GEARS WITH SMALL NUMBER OF TEETH

Unless otherwise requested, all gears in this catalogue having 16 teeth or fewer will be enlarged by applying addendum modification in accordance with BS4582 Part 1 (metric) as shown in the table below. These gears are indicated (†) against the appropriate tooth numbers on the product pages.

A small amount of backlash will be introduced between corrected pinions and mating gears when the modification sum is other than zero and the nominal centre distance is adjusted only by an amount equal to the modification sum.

For minimum backlash it will be necessary to either reduce the centre distance further, or to apply a secondary correction to the pinion or wheel. See the above B.S specification for details.

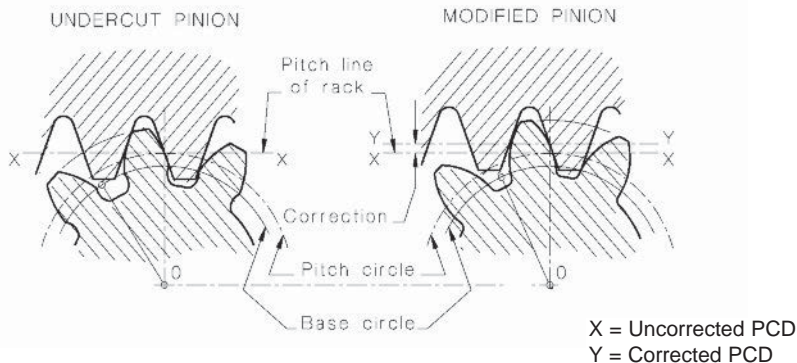

| Data for Addendum Modified Gears of Unit Module and Unit DP |                       |              |                     |
|---|-----------------------|--------------|---------------------|
| No. of Teeth  | Addendum Modification | Enlarged PCD | Enlarged OD (PCD+2) |
| 10  | 0.4151                | 10.8302      | 12.8302             |
| 11  | 0.3566                | 11.7132      | 13.7132             |
| 12  | 0.2982                | 12.5964      | 14.5964             |
| 13  | 0.2397                | 13.4794      | 15.4794             |
| 14  | 0.1812                | 14.3624      | 16.3624             |
| 15  | 0.1227                | 15.2454      | 17.2454             |
| 16  | 0.0642                | 16.1284      | 18.1284             |

### Example (Module)

Find P.C.D. and O.D. of enlarged gear having 13 teeth, 0.6 module

$$\begin{aligned} \text{P.C.D.} &= 13.4794 \text{ (from table)} \times 0.6 \text{ module} && = 8.088 \text{ mm} \\ & \text{(Standard P.C.D. would be } 13 \times 0.6) && = 7.800 \text{ mm)} \end{aligned}$$

Similarly,

$$\begin{aligned} \text{O.D.} &= 15.4794 \text{ (from table)} \times 0.6 \text{ module} && = 9.288 \text{ mm} \\ & \text{(Standard O.D. would be } 7.8 + (2 \times 0.6)) && = 9.00 \text{ mm)} \end{aligned}$$

### Note:

For Imperial (diametral pitch) gears, divide the PCD or OD value in the table by the diametral pitch. The answer will be in inches.



## ENGINEERING DATA

For instrumentation Reliance normally recommend stainless steel pinions mating with aluminium alloy gears. Generally the pinion is subjected to most wear since it experiences a higher number of stress cycles than the wheel. This combination of materials tends to balance the wear between the pinion and the gear.

### 1. Gear Materials

#### Stainless steel

The 300 series stainless steels are used for gears when maximum corrosion resistance is required. They are 'true' stainless steels containing 18% chromium and 8% nickel.

Gears made from 303 stainless steel are essentially nonmagnetic and cannot be hardened by heat treatment. They are recommended for low torque applications as their mechanical properties and resistance are low.

#### Hardened stainless steel

17-4PH is a precipitation hardening stainless steel that offers a remarkable combination of high strength and hardness. Its high chromium content (15-17.5%) makes it an excellent material for arduous environments.

#### Aluminium alloy

Gears made from aluminium alloy are widely used in measuring applications. Its light weight offers reduced inertia. The inertia of an aluminium alloy gear is approximately 35% that of a steel gear. In particular, aluminium alloy L168 offers excellent corrosion resistance when anodised, moderately good mechanical properties and good stability.

#### Phosphor bronze

As a gear material phosphor bronze has a fine grain and good resistance to tooth sliding wear hence its use as a worm wheel material.

### 2. Installation

Gears in this catalogue are designed to be a slide fit on the shafts. The gears are available with four fixing methods: standard clamp, pins, set screws and Reli-a-Grip™ clamp.

Traditional clamp hub style gears have a gear hub with a relatively thin wall partially split. The clamp is a close fit on the hub and is compressed when the clamp screw is tightened. Clamping gears onto the shaft offers extremely easy assembly with the best assembled accuracy. However, as the fastening depends upon friction it can only be used in low torque applications.

Pin type gears are supplied as standard with a set screw and a sub-drilled hole. The set screw should be used to position the gear on the shaft during the drilling and pinning operation and can be removed once the gear is secure.

The sub-drilled hole provides a lead in for the drilling operation. It is recommended that drilling and pinning is completed outside the gearbox and the gear is thoroughly cleaned afterwards.

In less critical applications the set screw may be used to retain the gear on the shaft. To avoid damaging the shaft and to make removal of the gear easier the set screw should seat on a small flat, or dimple on the shaft.



### 3. Lubrication

All gears should be lubricated, but there are variations in degree.

Highly loaded precision gears should be in enclosed assemblies with complete lubrication to obtain the best possible hydrodynamic film. The system can be splash, spray or force fed, depending on the application. Moderately loaded precision gears, such as fractional horsepower systems, should be enclosed with oil or grease lubrication which can be spread by splash or dip lubrication.

Lightly loaded gears in instrumentation systems only need to have a marginal boundary lubrication as provided by periodically wiped on oils or grease. In many instances a light coat of Rocol MT LM or similar molybdenum disulphide grease will suffice for the life of the system. Anti-backlash gears should not be directly lubricated except via a very light application on the mating pinion.

Negligibly loaded fine instrument gears only need a brushed on film of light oil as a simple means of reducing friction.

### 4. Speed

The maximum pitch line velocity for stainless steel meshing with aluminium alloy with boundary lubrication is approximately 5,300 mm/sec (for a pair of meshing actuation gears correctly lubricated, this rises to approximately 8,000 mm/sec). This represents 5,000 rpm on measurement gears of 20 mm diameter (and 7,500 rpm on actuation gears of 20 mm diameter).

For speeds in excess of this and other material combinations please consult Reliance technical sales.

### 5. Gear Loading

The gears in this catalogue can be used for both feedback and actuation systems. The loads and material selection will depend on the application. In general a feedback system is designed to maintain accuracy and an actuation system is designed to transmit power.

#### 5.1. Actuation Gears

The following analysis is intended to give a guide to the load capacity of a pair of spur gears. To simplify the calculations, a number of assumptions have been made. It must be noted that in many applications this will give a conservative estimate of the gear capacity, therefore, in critical applications an exact analysis must be completed.

Please consult the relevant gear standards or Reliance Technical Sales.

The analysis is based on AGMA 2001-B88 and assumes the following:

1. The gears are simply supported in rolling element bearings.
2. Pinion revolutions  $>10^7$ .
3. Gears are grease lubricated.
4. Reliability of 1 failure in 100 is acceptable.
5. Gear material is 17-4PH hardened.



The basic load capacity ( $F_b$ ) of a pair of spur gears is defined as the maximum tangential force at which they can operate indefinitely.

$F_b$  has two values: one calculated from tooth root strength ( $F_{bs}$ ), and one for tooth flank pitting ( $F_{bw}$ ). The useful or transmitted load capacity,  $F_t$ , is usually less than  $F_b$  due to transient or dynamic loads generated within the mechanism.

|                                |                       |                                     |
|--------------------------------|-----------------------|-------------------------------------|
| For tooth root strength        | $F_{ts} = F_{bs}/K_a$ | $K_a$ & $C_a$ = Application factors |
| For tooth flank pitting (wear) | $F_{tw} = F_{bw}/C_a$ |                                     |

Both calculations should be made and the lower value used.

The application factors  $K_a$  and  $C_a$  make allowance for any externally applied loads in excess of the nominal tangential force  $F_b$  and they are most accurately determined by direct measurement. In determining application factors, consideration should be given to the fact that many prime movers develop momentary peak torques appreciably greater than those determined by the nominal ratings of either the prime mover or the driven equipment. There are many possible sources of overload which should be considered including system vibrations, acceleration torques, overspeeds, variations in system operation and changes in process load. Impact loads due to reversing across backlash can be significant in servo systems.

As a general guide application factors for a motor gear system range from 1.0 for uniform loads up to 1.75 where heavy shock loads are anticipated.

|              |   |     |   |
|--------------|---|-----|---|
| For strength | $F_{bs} = 177.7 \times J \times F \times M \times K_v$          | [N] | $F_b$ = Basic load capacity ( $F_{bs}$ & $F_{bw}$ )<br>$N$ = Number of teeth<br>$J$ = Geometry factor, strength<br>$I$ = Geometry factor, wear<br>$F$ = Face width of smallest gear<br>$M$ = Module<br>$K_v$ = Dynamic factor |
| For wear     | $F_{bw} = 14.64 \times N \times I \times F \times M \times K_v$ | [N] |   |

(i) Number of teeth

This is the number of teeth in the gear being analysed.

(ii) Geometry factors, I and J

These factors take account of the effect of tooth proportions on stress. The bending strength geometry factor, (J) takes account of the shape of the tooth. The wear resistance geometry factor, (I) takes account of the radii of curvature of the contacting tooth profiles. Please see the graphs on [page T4-13](#).

(iii) Face width, F

This is the face width of the smallest gear in mm. (Face width in contact).

(iv) Module, M

This is the gear module expressed as shown on the respective gear pages.

(v) Dynamic factor,  $K_v$

This accounts for internally generated gear tooth loads which are induced by the non-conjugate meshing action of the gear teeth.



$$K_v = \left( \frac{84}{84 + \sqrt{200V_t}} \right)^{0.4}$$

For quality 10 gears only  
 $V_t$  = Pitch line velocity (m/s)

Example calculation to find the theoretical load capacity of a 5:1 pass of 17-4PH spur gears as follows:

Pinion - P06S8B6F4A-25  
 Gear - P06S8B8F6A-125

Pinion speed is 500 rpm.

- (i) Number of teeth from part number = 25
- (ii) Geometry factors from graph

$$J = 0.37$$

$$I = 0.118$$

- (iii) Smallest gear face width from part number

$$F = 4$$

- (iv) Gear module from part number

$$M = 0.6$$

- (v) Dynamic factor from equation

$$K_v = \left( \frac{84}{84 + \sqrt{200V_t}} \right)^{0.4} = \left( \frac{84}{84 + \sqrt{200 \times 0.393}} \right)^{0.4} = 0.96$$

$$\text{where : } V_t = \frac{\text{rpm} \times \pi \times N \times M}{60000} \text{ [m/s]}$$

$$F_{bs} = 177.7 \times 0.37 \times 4 \times 0.6 \times 0.96 = 151.5 \text{ N}$$

$$F_{bw} = 14.64 \times 25 \times 0.118 \times 4 \times 0.6 \times 0.96 = 99.5 \text{ N}$$

For alternative materials the above values need to be modified as shown below:

| Gear Material Modification Factors |               |          |      |
|------------------------------------|---------------|----------|------|
| Material                           | Specification | Strength | Wear |
| Hardened stainless steel           | 17-4PH        | 1.00     | 1.00 |
| Stainless steel                    | 303S31        | 0.43     | 0.15 |
| Stainless steel                    | 316S31        | 0.47     | 0.20 |
| Aluminium alloy                    | L168          | 0.37     | 0.10 |
| Brass                              | CZ121         | 0.35     | 0.13 |



Example:

If the gears in the example on the previous page were made from 303S31

$$F_{bs} = 151.5 \times 0.43 = 65.1 \text{ N}$$

$$F_{bw} = 99.5 \times 0.15 = 14.9 \text{ N}$$

The application factors should be applied after the reduction for material.

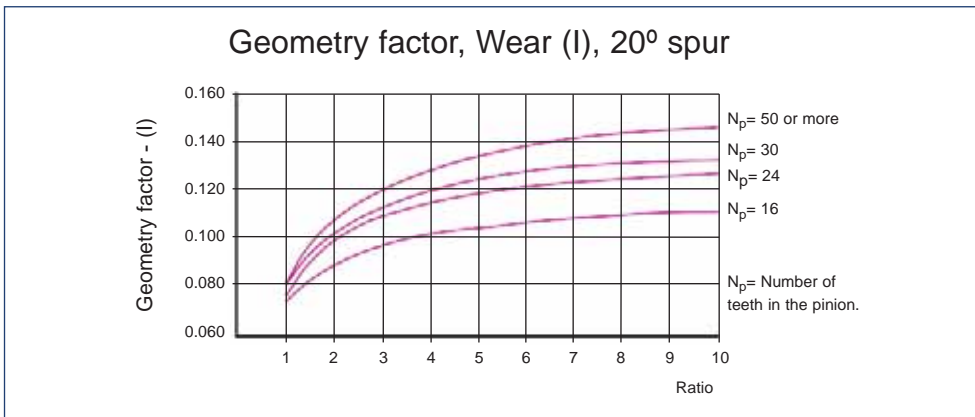
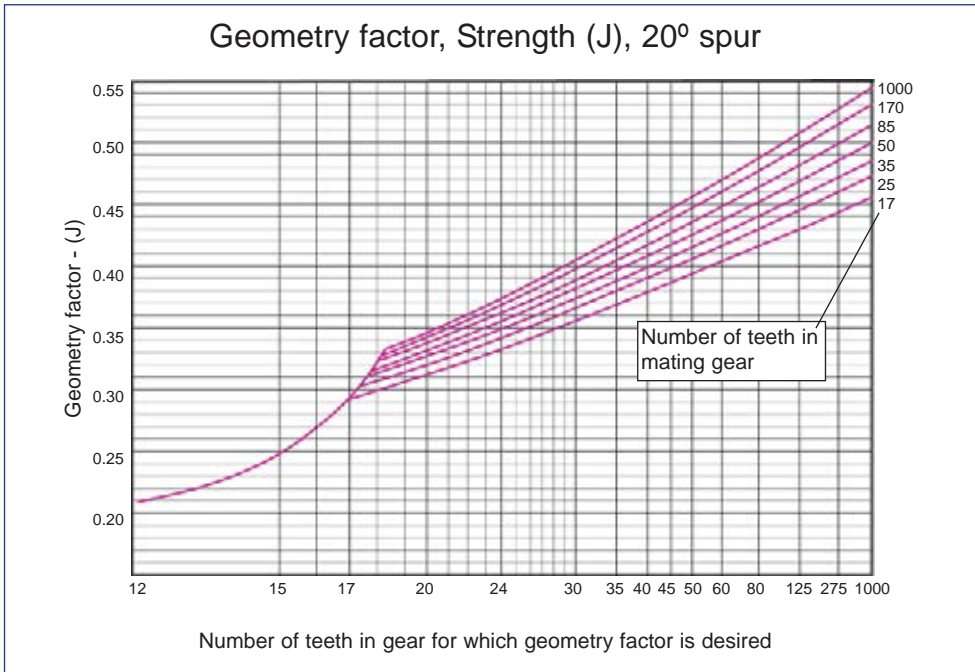



## 5.2. Instrumentation and Feedback Systems

Gears and components designed for the precise transmission of angular position generally work at the low torque levels normally associated with servo components such as synchros, resolvers, optical encoders etc. Tooth loads of 1.2 N per mm face width should result in an adequate accurate life. Higher loads will tend to increase deflections of gear teeth, shafts, bearings etc, resulting in significant values of lost motion and a decrease in life.

Example: To find the maximum advisable torque on a gear 40 mm diameter x 3 mm face width.

Torque = force x radius =  $1.2 \times 3 \times 0.04/2 = 0.072 \text{ Nm}$  (10 oz.in.)

## 5.3. Anti-backlash Gear Spring Tension

In order for anti-backlash gears to function as anti-backlash devices, it is necessary to ensure that the spring tension will provide sufficient torque to overcome the friction and acceleration torque in the system, ie the spring torque must be capable of driving/accelerating the gear train and any associated components.

The spring tension capability of anti-backlash gears listed in this catalogue will adequately cope with the low torques normally encountered.

As a general guide, torque settings on anti-backlash gears of 1.059 to 1.765Ncm (1.5 to 2.5 oz.in.) will suffice in most applications. Ideally the spring torque should be set to the minimum at which the anti-backlash gear performs satisfactorily, thus avoiding unnecessary high preload on the gear teeth and premature wear.

## 6. Lost Motion and Backlash Control

The following section deals with lost motion, which we know to be one of the basic problems in designing fine pitch gear trains. The accepted definition of lost motion is the amount by which the output shaft may be turned without turning the input shaft.

It may be thought that lost motion is a function of the gear cutting operation alone, but, in fact the teeth of the gears may contribute very little to the overall lost motion value. A complete understanding of all the elements which induce lost motion is essential in order to achieve a well designed gear train. The following factors must be individually considered for their own contribution to overall lost motion in the gear train:

- (a) Nominal centre distance.
- (b) Centre distance tolerance.
- (c) Size and tolerance of mating gears.
- (d) Total composite error of gears.
- (e) Fits between bores, shafts and bearings.
- (f) Bearing accuracy (class).
- (g) Radial play of bearings.
- (h) Shaft straightness and alignment.
- (i) Fits between electrical and/or mechanical component spigot diameters, and housing bores.
- (j) Eccentricity and radial play of electrical and/or mechanical component shafts.
- (k) Torsional elasticity.
- (l) Differential expansion.





Each of the previous, except nominal centre distance, tend to induce a change in centre distance which will push together or pull apart the mating gears. This push-pull action produces two backlash values, minimum at the point of the tightest mesh, and maximum at the point of loosest mesh.

### (a) Calculation of Nominal Centre Distance

Nominal centre distance can be considered as the starting point in the calculation of overall backlash values. Nominal centre distance is calculated by taking half the sum of the (theoretical) pitch diameters of the mating gears.

$$\text{i.e. } CD = \frac{PCD_1 + PCD_2}{2}$$

### (b) Centre Distance Tolerance

Centre distance tolerance is an extremely important area for consideration. Any increase in centre distance in excess of the nominal value will increase the backlash. A decrease in nominal centre distance will decrease the backlash. In this case caution must be exercised to avoid interference between mating gears as a result of this decrease.

The relationship between centre distance change to backlash for 20° PA spur gear is given by:

$$B = 2 \tan \phi \cdot \Delta C \quad \text{where}$$

**B = Circumferential backlash**  
 **$\phi$  = Pressure angle (Tan 20° = 0.36397)**  
 **$\Delta C$  = Distance between theoretical nominal and actual centre distance**

Note: Maximum Angular Backlash =  $\frac{\text{Maximum Circumferential Backlash} \times 57.3 \times 60}{\text{Pitch Circle Radius}}$   
(minutes of arc)

## 7. Gear Error

The error function of a gear is approximately sinusoidal and for practical considerations can be assumed to be so. The first derivative of the time displacement curve yields the velocity function, therefore, the output velocity variable will also be an approximate sinusoid but the maximum velocity error will be displaced 90° from the maximum position error.

In summation, pitch circle runout will cause a sinusoidal error which is revealed as an output transmission error when meshed with a mating gear. The magnitude is given by the following example:

In the example on [page T4-16](#), if the small pinion were not a perfect gear its error would be seen superimposed on the large gear error cycling at pinion frequency.

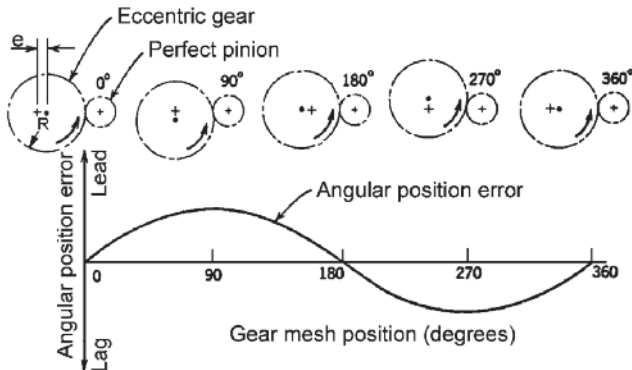

Angular position error  $E_A = \frac{e}{R} \sin\theta$

Linear position error  $E_L = e \sin\theta$

8. Transmission Accuracy of Gear Trains

The following section is based on work carried out by Reliance Gear Company (now known as Reliance Precision Limited) to provide some guidance in the design of accurate data transmission gearing.

The transmission error referred to by equations 1 and 2 below represent the maximum statistical point to point error during a forward and reverse cycle of a single pass of quality 14 anti-backlash gearing assembled in a data transmission gearbox.

For quality 10 or 12 gearing add 50% or 30% respectively to the error calculated for quality 14 gearing.

For average transmission error substitute the numbers 3.25 and 83 in the equations for the numbers 4.4 and 112 respectively.

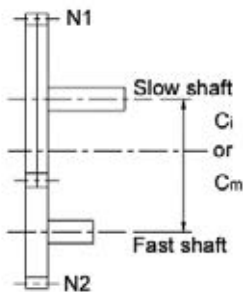

$$\Sigma_1 = \left( 1 + \frac{N_2}{N_1} \right) \cdot \left( \frac{112}{C_m} \text{ or } \frac{4.4}{C_i} \right) \text{-----(1)}$$

$$\Sigma_2 = \left( 1 + \frac{N_1}{N_2} \right) \cdot \left( \frac{112}{C_m} \text{ or } \frac{4.4}{C_i} \right) \text{-----(2)}$$

$C_m$  and  $C_i$  = Centre distance in mm and inches respectively.  
 $N_2$  and  $N_1$  = Number of teeth in pinion and wheel respectively.  
 $\Sigma_1$  and  $\Sigma_2$  = Maximum statistical transmission error in minutes of arc measured at the slow and fast shafts respectively.



### BACKLASH FOR STANDARD GEARS

The table below refers to the allowable backlash within the range of Spur, Bevel, and Worm gear pairs with a designated centre distance. The allowable backlash is necessary to absorb the deviations of noise and oscillation in order to maintain smooth operation.

| Gear Type                         | Condition                                    | Module (m)  | Backlash (mm)       |
|-----------------------------------|--|-------------|---------------------|
| Spur Gear                         | Brass/ Ground                                | < 0.9       | 0.02 - 0.06         |
|                                   | Brass  | 0.9 to 0.75 | 0.04 x m - 0.10 x m |
|                                   | Ground                                       | 0.9 to 1.0  | 0.04 x m - 0.08 x m |
| Bevel Gear pair                   | Stainless steel or Brass                     | < 0.9       | 0.02 - 0.08         |
|                                   |  | 0.9 to 1.5  | 0.05 - 0.12         |
| Worm Gear pair<br>Centres < 50 mm | Worm - Stainless steel<br>Worm wheel - Brass | ≤ 1.0       | 0.08 - 0.20         |

Note. These figures apply to the standard gear range only.

To convert Circumferential Backlash to Angular Backlash see [page T4-15](#)

### TYPICAL GROUND GEARS ALLOWABLE TRANSMISSION CAPACITY

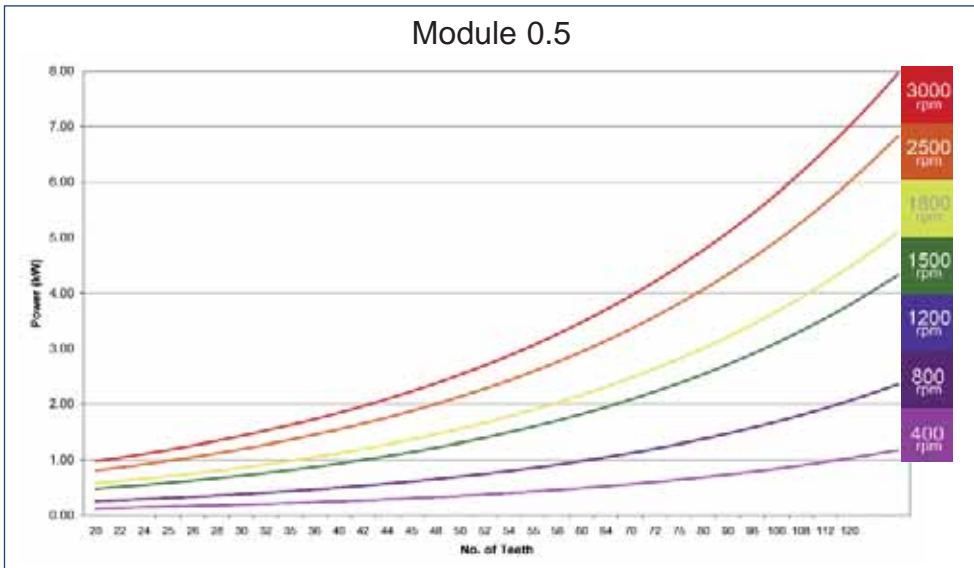



### Module 0.8

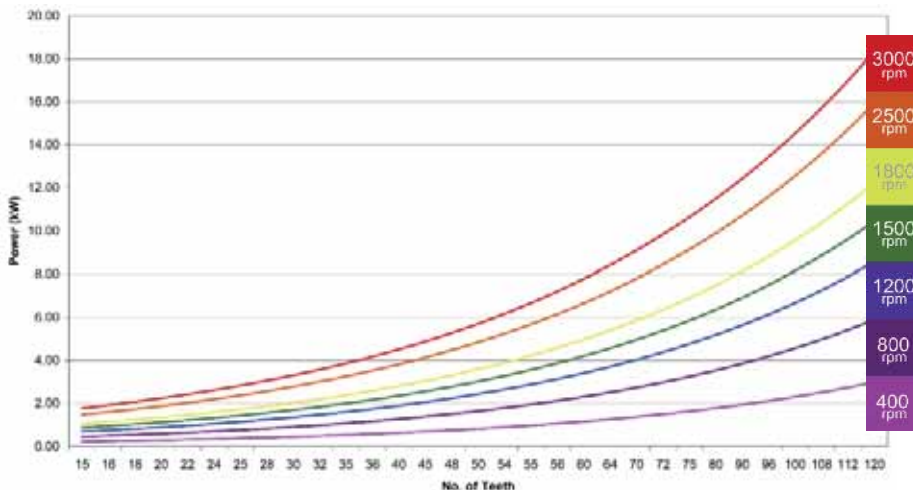

### Module 1.0

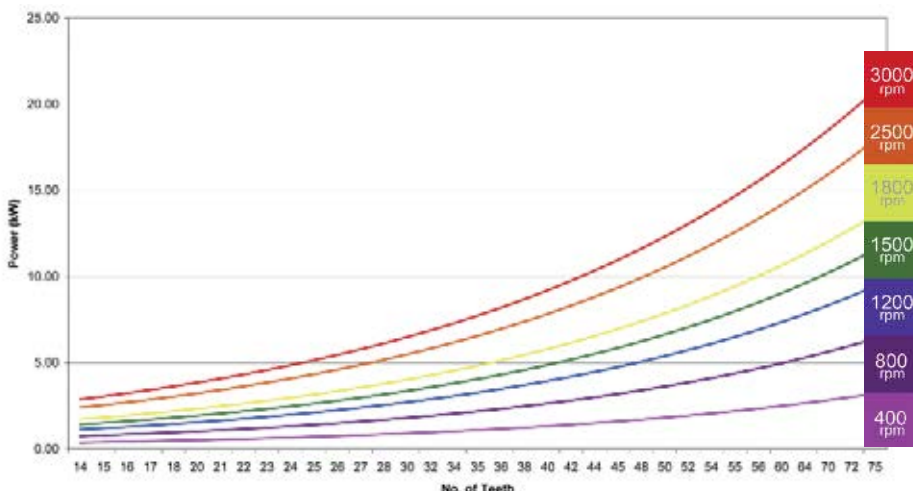



### WORMS AND WHEELS FORMULAE

**Ratio (R)** =  $\frac{\text{No. of teeth on wormwheel (T)}}{\text{No. of starts on worm (t)}}$

**Centre Distance (CD)** =  $\frac{\text{PCD worm}}{2} + \frac{\text{PCD wheel}}{2}$

**Lead (L)** = The axial distance by which a thread advances in one revolution =  $\pi \times t \times m$

Where  $m$  (metric) = Axial module

$m$  (imperial) =  $\frac{1}{\text{DP}}$

**Actual outside diameter of worm**  $\text{OD}_w = \text{PCD} + (2 \times m)$

**Typical outside diameter of wormwheel**  $\text{OD}_{ww} = \text{PCD} + (3 \times m)$





## RACK MANUFACTURE

Reliance standard precision racks are produced by a thread grinding process, which generates teeth of helicoidal form. This provides two distinct advantages: very good pitch accuracy and sufficient tolerance of meshing conditions (within 0.25°) to make high precision alignment of the pinion unnecessary.

This feature will be appreciated from the diagram below. Slight misalignment of the straight-tooth pinion, in terms of deviation from a true right-angle between the axis and rack in either plane, results merely in a change of position of the contact points across the face.

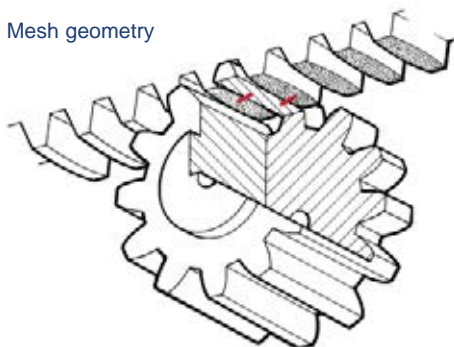

Points of contact.  
Standard pressure angle is 20°. 25° pressure angle available on request.

## RACK STANDARDS AND TOLERANCES

Reliance precision racks are offered in four basic grades of accuracy through most of the range, please see the individual product pages for details. Grade 4b has been introduced to offer a lower cost grade 4 where a single rack is to be used in a non-butting application.

The tooth form is generally in accordance with BS 4582 part 1. fig 1. for metric racks.

| Rack Grade  | 5            | 4            | 4b           | 3            | 2            | 1            |
|---|--------------|--------------|--------------|--------------|--------------|--------------|
| Max pitch error between any two points per 300 mm of rack | 0.005        | 0.008        | 0.008        | 0.015        | 0.025        | 0.050        |
| Max end to end pitch error up to 300 mm of track*         | ±0.004       | ±0.004       | ±0.008       | ±0.008       | ±0.013       | ±0.025       |
| Adjacent tooth error                                      | 0.0025       | 0.0025       | 0.0025       | 0.005        | 0.010        | 0.013        |
| Pitch height variation                                    | +0<br>-0.013 | +0<br>-0.013 | +0<br>-0.013 | +0<br>-0.013 | +0<br>-0.018 | +0<br>-0.025 |

\* Applies pro rata to length >300 mm

All dimensions in mm



### ENGINEERING DATA

#### 1. Linear Speed

Linear speeds of up to 10 m/s can be achieved with correctly installed rack and pinion systems. When specifying a system, care needs to be taken to ensure that the transducer count rates are not exceeded. With grease lubrication, care should be taken to ensure that the lubrication is not thrown off the pinion

#### 2. Load Capacity

The following analysis is intended to give a guide to the load capacity of a rack system. To simplify the calculation a number of assumptions have to be made. In many applications this will give a conservative estimate of the gear capacity, therefore in critical applications an exact analysis must be completed. Please consult the relevant gear standards or Reliance Technical Sales.

The basic load capacity ( $F_b$ ) of a rack and pinion is defined as the maximum linear force at which they can operate indefinitely.

$F_b$  has two values: one calculated from tooth strength ( $F_{bs}$ ) and one for tooth flank wear ( $F_{bw}$ ). The useful or transmitted load capacity,  $F_t$ , is usually less than  $F_b$  due to transient or dynamic loads generated within the mechanism.

For tooth root strength  $F_{ts} = F_{bs}/K_a$   $K_a \& C_a =$  application factors

For tooth flank pitting (wear)  $F_{tw} = F_{bw}/C_a$

Both calculations should be made and the lower value used.

The application factors  $K_a$  and  $C_a$  make allowance for any externally applied loads in excess of the nominal linear force  $F_b$ . These are most accurately determined by direct measurement. In determining application factors, consideration should be given to the fact that many prime movers develop momentary peak torques appreciably greater than those determined by the nominal ratings of either the prime mover or the driven equipment.

There are many possible sources of overload which should be considered, including system vibrations, acceleration torques, overspeeds, variations in system operation and changes in process load conditions. Impact loads due to reversing across backlash can be significant in servo systems.

As a general guide application factors for a motor gear system range from 1.0 for uniform loads up to 1.75 where heavy shock loads are anticipated.

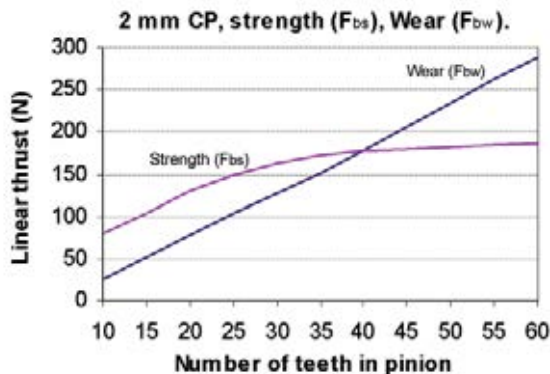



The previous graph has been calculated in accordance with AGMA 2001-B88 for a life of at least 10<sup>8</sup> load cycles, and a rack hardness exceeding 50 HRc and pinion material 17-4PH. For alternative pitches and materials the graph values need to be modified as shown in the table below:

| Pitch and Rack/Pinion Material Modification Factors |              |            |          |      |
|---|--------------|------------|----------|------|
| Rack  | Pinion       | Pitch (mm) | Strength | Wear |
| Hardened Round Rack<br>(hardness>50 HRc)            | 17-4PH       | 1          | 0.50     | 0.50 |
|   | 316          | 1          | 0.23     | 0.10 |
|   | PEEK polymer | 1          | 0.04     | 0.01 |
| Rectangular Rack<br>(hardness 35-45 HRc)            | 17-4PH       | 1          | 0.38     | 0.28 |
|   |              | 2          | 0.75     | 0.56 |
|   |              | 2.5        | 0.94     | 0.70 |
|   | 316          | 1          | 0.23     | 0.10 |
|   |              | 2          | 0.47     | 0.20 |
|   |              | 2.5        | 0.59     | 0.25 |
|   | PEEK polymer | 1          | 0.04     | 0.01 |
| Tubular and Round<br>Rack                           | 17-4PH       | 1          | 0.23     | 0.10 |
|   | 316          | 1          | 0.23     | 0.10 |
|   | PEEK polymer | 1          | 0.04     | 0.01 |

Example:

A 40 tooth, 1 mm CP pinion material 316 meshing with rack of hardness <50 HRc.  
The application factors should be applied after the reduction for material and pitch.

$$F_{bw} = 175 \times 0.10 = 17.5 \text{ N}$$

$$F_{bs} = 170 \times 0.23 = 39.1 \text{ N}$$

### 3. Bearing Capacity

When linear bearings are used with the hardened round bar racks the capacity of the support bearings needs to be considered. Where possible the bearings should be positioned with all the ball rows running on the rack shaft. However, it is important that the balls do not run on the edges of the teeth. If necessary the 5 and 6 row bearings can be used with 1 row above the teeth. In this scenario, the manufacturer's ratings apply with a modification for the direction of the load application. The factors given in the following charts should be substituted for the bearing manufacturer's load reduction.





Closed bearing 5 rows of balls

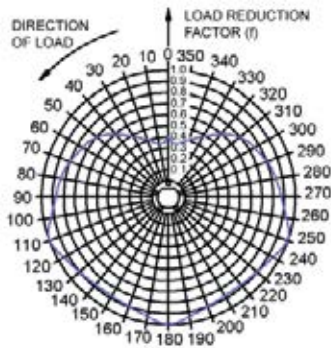

Closed bearing 6 rows of balls

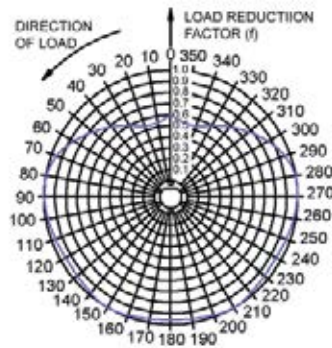

#### 4. Lubrication

Lubrication is not required when using PEEK polymer pinions. For other combinations unlubricated systems are not recommended. Measurement applications should use a very thin coat of light oil, in many machine tool applications stray cutting oil is sufficient. Grease lubrication is recommended for higher loads, but care should be taken to ensure the lubrication is not thrown off the pinion at speed.

### INSTALLATION

The installation techniques differ according to the type of rack. All racks should be mounted with teeth pointing downwards wherever possible so that dust etc cannot settle in them.

#### 1. Soft Round and Tubular Rack

Plastic moulded bearings are recommended for use with soft round and tubular racks, these can be found in the Bearings and Spacers section of the Reliance catalogue. Round racks are not recommended for multi-section use.

#### 2. Hardened Round Rack

Bearings for the round bar rack should be fitted in accordance with the manufacturer's instructions. It is important that the balls do not run on the edge of the teeth. Round racks are not recommended for multi-section use.

#### 3. Rectangular Rack

Reliance rectangular section rack is manufactured to enable butting to form infinite lengths. Socket head cap screws, plain washers and a thread locking adhesive are preferred for mounting. Dowels are not recommended. The pitch line of the rack in its constrained position must be straight to obtain maximum accuracy. To avoid distortion, racks should be screwed to a machined flat surface.

## Machining requirements for rack location

1. Pinion clearance
2. Clearance required if:
  - a) anti-backlash pinions are used
  - b) full face of rack is to be used
3. Abutment
4. Mounting face

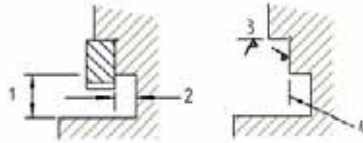

To align racks, two adjustments need to be made, pitch line alignment and pitch adjustment. The pitch line straightness is not critical (see drawing below) but steps at the joints should be avoided as they can lead to excessive noise and wear.

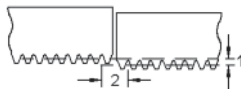

1. Pitch line alignment
2. Pitch adjustment and error compensation

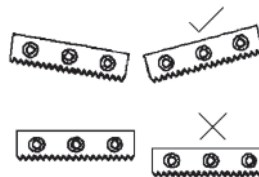

### Pitch Line Alignment

There are three methods of setting the pitch line at a joint. These are:

- i) Setting the base of the racks against an abutment perpendicular to the mounting face. The misalignment is then governed by the rack pitch line to base tolerance.
- ii) Using the tops of the rack teeth as a reference. These are parallel to the pitch line within 0.008 mm. Use a short straight edge (eg. slip block) as shown below.
- iii) The best measurement of the pitch line is with the pinion installed on a flexplate. A dial indicator fitted as shown gives a direct reading of the pitch line straightness.

Pitch line alignment using slip block

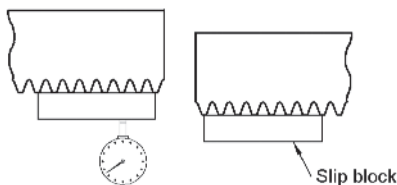

Dial indicator carried with flexplate

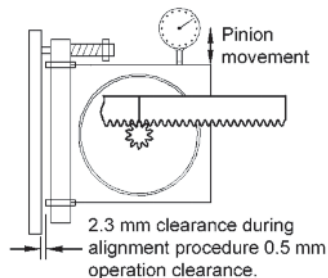

The flexplate spring loads the pinion into mesh on both flanks of the teeth, ensuring complete backlash elimination.



## Pitch Adjustment and Error Correction

Pitch accuracy can be obtained by one of three methods depending upon accuracy required.

### GRADE 1 (and for the initial setting of all grades)

For pitch accuracy across the joint of  $\pm 0.020$  mm the Rack Setting Piece is the simplest method.

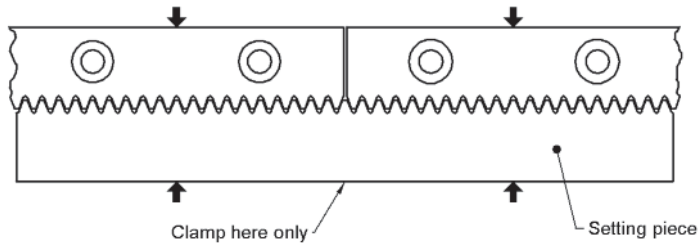

### GRADE 2, 3 or 4

After initial setting and with the measuring system functioning, length bars may be used as references. Checks made against these allow adjustment to be made within the system resolution.

### GRADE 3, 4 or 5

After initial setting and with the measuring system functioning, comparison should be made with a laser measuring system. This allows pitch adjustment and machine error compensation within the system resolution over the full travel of the axis.

## RACK APPLICATIONS

Reliance precision racks are manufactured in both round and rectangular sections, and can be used for both measurement and actuation. In general the smaller pitches (1mm) are ideal for measurement, as the smaller pinion diameter gives higher linear resolutions. The larger pitches (2 mm and 2.5 mm) allow a higher load capacity.

For most applications the rack can be used for both the feedback and the actuation. In very precise applications we recommend that an unused section of the actuation rack is used for feedback. Alternatively a separate rack can be used.

All Reliance racks are calibrated to measure correct at 20°C using a temperature compensated laser. Calibration graphs can be supplied if required.

## RACK ACTUATOR

Information about the Rackuator™ is provided on [page T2-9](#).



## FEATURES

Reliance's precision leadscrew assemblies are designed specifically for motion control applications where accuracy must be maintained. Rather than being adaptations of general purpose screws or nuts they have a precision rolled screw thread which has been designed for maximum life and quiet operation.

A further enhancement available on stainless steel leadscrews up to 2.4 metres long is a specially formulated TFE coating which can extend normal nut life by up to 300%.

Innovative anti-backlash nut designs provide assemblies which are wear compensating with low frictional drag torques and excellent positional repeatability.

Reliance stainless steel leadscrews offer the following:

### 1. High Accuracy

Precision thread rolling process provides a standard lead accuracy of 0.0006 mm/mm. Higher accuracies up to 0.0001 mm/mm can be provided.

The unloaded repeatability of anti-backlash assemblies is within 0.0013 mm.

### 2. Long Life

More than 7.5 million metres of travel can be expected.

### 3. Low Drag Torque

An anti-backlash nut design which does not require high spring forces to maintain bi-directional anti-backlash characteristics gives very low nut to screw friction.

### 4. Low Maintenance

Self lubricating and wear compensating nuts eliminate the need for repeated lubrication or adjustment.

### 5. Wide Range

Diameters from 3.2 mm to 24 mm.

Leads from 0.30 mm to 92 mm.

Lengths up to 4 metre.

### 6. Custom Thread Design

Unique thread form designed specifically for leadscrews in anti-backlash applications.

### 7. Smooth Quiet Operation

No recirculating ball noise or metal to metal contact.

### 8. Lower Cost

Less than comparable ball screws or ground leadscrews, while still providing high accuracy and long life.

### 9. Modifications

Special leadscrew ends and other leads are available on the stainless steel leadscrew range in selected sizes. Please contact Reliance Technical Sales or refer to the leadscrews modification section of this brochure.



### ENGINEERING DATA

#### 1. Lead

The lead of the screw is the amount of linear movement of the nut for one revolution of the leadscrew.

#### 2. Drive Torque

The required motor torque to drive a leadscrew assembly is the sum of three components: inertial torque, static friction torque and torque to move the load. Additional torque associated with driving and supporting the leadscrew must also be considered.

Inertial torque:  $T = I\alpha$        $I = \text{Inertia of leadscrew (kgm}^2\text{)}$   
 $\alpha = \text{Angular acceleration (rads/s}^2\text{)}$

Static friction torque: Anti-backlash leadscrews are typically supplied with a static frictional torque of 0.007 - 0.05 Nm. Higher pre-load forces lead to higher frictional drag torques but better anti-backlash characteristics.

Torque to move load: The torque to move a certain load is a function of the lead and efficiency of the leadscrew assembly.

$$\text{Torque} = \frac{\text{Load} \times \text{Lead}}{2\pi \times \text{Efficiency}}$$

Torque = Newton metres  
 Load = Newtons  
 Lead = Metres

(Note - efficiency of 70% would require 0.7 in these equations)

#### 4. Backdriving

In general when the screw pitch is less than 1/3 its diameter and the screw is uncoated, backdriving will not occur. (Coated screws require to be 1/4 diameter). For higher leads where backdriving is likely, the torque required for holding a load is as follows:

$$\text{Backdrive torque} = \frac{\text{Load} \times \text{Lead} \times \text{Efficiency}}{2\pi}$$

Torque = Newton metres  
 Load = Newtons  
 Lead = Metres

Small vibrations in the system may break the static friction initiating backdriving, therefore, for small critical applications use smaller lead or an external locking device.

#### 5. Traverse Speed

The polyacetal nut materials provide long wear-life over a wide variety of conditions, but very high loads and/or high speeds will accelerate nut wear. We recommend the following maximum linear traversing speeds for optimum life:

| Lead           | Maximum traverse speed |
|----------------|------------------------|
| 2.5 mm - 12 mm | 100 mm/sec             |
| 12 mm - 25 mm  | 250 mm/sec             |
| 25 mm - 60 mm  | 760 mm/sec             |



## 6. Critical Speed

This is the rotational speed at which a leadscrew will experience vibration or other dynamic problems. See the critical speed chart below to determine if the application parameters result in speeds approaching critical.

To minimise critical speed problems use a longer lead, choose a larger diameter screw or increase the bearing mount support.

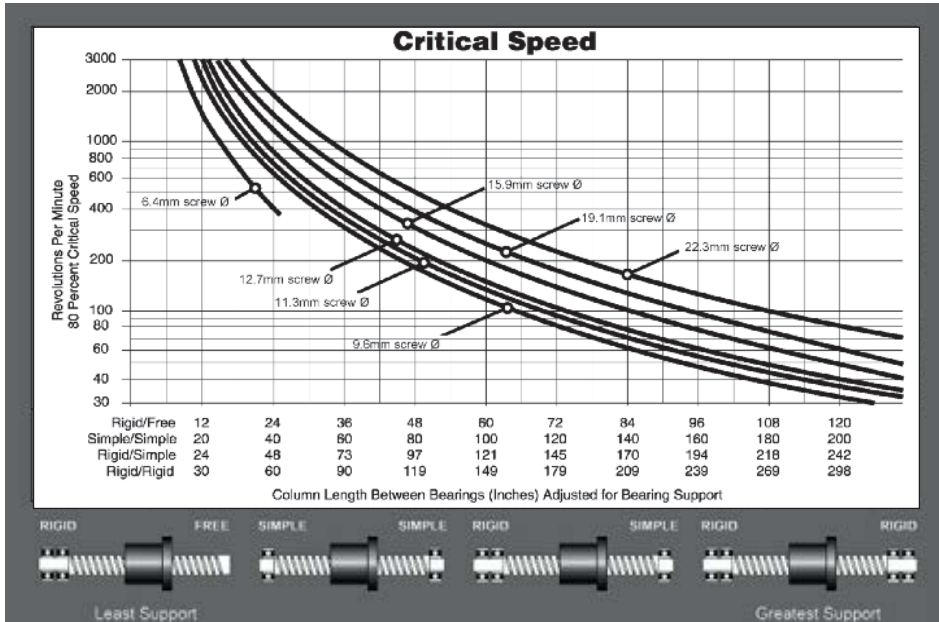

## 7. Maximum Load

Although the leadscrew assemblies are able to withstand relatively high loads without catastrophic failure, these units have been designed to operate with the loads shown on the product pages.

## 8. Efficiency

The efficiency of a leadscrew varies with the lead angle of the screw. The theoretical maximum efficiencies of all our leadscrews are given in the part number tables on the product pages. These have been calculated using the static coefficient of friction 0.08. For applications where the dynamic efficiency is critical please contact Reliance Technical Sales.

## 9. Leadscrew Inertia

Values of leadscrew inertia are given in the Typical Mechanical Properties chart on the next page.

## 10. Screw Straightness

Typical screw straightness is 0.25 mm/metre.

## 11. Leadscrew Interfacing

Examples of machined end options can be found on pages 7-27 to 7-35.



| Physical Properties        |                    |                                      |                                   |                       |   |
|----------------------------|--------------------|--------------------------------------|-----------------------------------|-----------------------|---|
| Leadscrew                  |                    | Nuts                                 |                                   | Assembly              |   |
| Material                   | Surface Finish     | Material                             | Tensile Strength                  | Operating Temp. Range | Coefficient of Friction Nut to Screw                                    |
| Stainless steel 303 series | Better than 0.4 µm | Polyacetal with lubricating additive | 67 N/mm <sup>2</sup><br>9,700 psi | 0 - 93°C              | Static = 0.08 0.08#<br>Dynamic = 0.15 0.09#<br><br># - with TFE coating |

| Typical Mechanical Properties                                       |  |  |  |  |
|---|--|--|--|--|
| Leadscrew Series  | Static Frictional Drag Torque (Nm)   | Screw Inertia<br>kg m <sup>2</sup> /m  | Anti-backlash Life +                     |  |
|   |  |  | Plain Screw                              | TFE Coated Screw                         |
| LPX6<br>LPX10<br>LPX11<br>LPX13<br>LPX16<br>LPX19<br>LPX22<br>LPX24 | Free wheeling  | 8.340x10 <sup>-7</sup><br>4.170x10 <sup>-6</sup><br>9.730x10 <sup>-6</sup><br>1.446x10 <sup>-5</sup><br>3.948x10 <sup>-5</sup><br>8.479x10 <sup>-5</sup><br>1.612x10 <sup>-4</sup><br>2.030x10 <sup>-4</sup> | N/A<br>Typical Backlash<br>0.076-0.25 mm | N/A<br>Typical Backlash<br>0.076-0.25 mm |
| LNTG6<br>LNTG8<br>LNTG10  | 0.004-0.01<br>0.01-0.02<br>0.01-0.02   | 8.340x10 <sup>-7</sup><br>1.390x10 <sup>-6</sup><br>4.170x10 <sup>-6</sup>   | 0.12 - 0.25 million metres               | 0.38 - 1.0 million metres                |
| LAB6<br>LAB10<br>LAB11<br>LAB13<br>LAB16<br>LAB19<br>LAB22<br>LAB24 | 0.004-0.01<br>0.01-0.02<br>0.015-0.03<br>0.015-0.03<br>0.02-0.05<br>0.03-0.063<br>0.03-0.063<br>0.03-0.063 | 8.340x10 <sup>-7</sup><br>4.170x10 <sup>-6</sup><br>9.730x10 <sup>-6</sup><br>1.446x10 <sup>-5</sup><br>3.948x10 <sup>-5</sup><br>8.479x10 <sup>-5</sup><br>1.612x10 <sup>-4</sup><br>2.030x10 <sup>-4</sup> | 0.12 - 0.25 million metres               | 0.38 - 1.0 million metres                |
| LAF6<br>LAF8<br>LAF10<br>LAF11<br>LAF13<br>LAF16                    | 0.004-0.02<br>0.01-0.03<br>0.01-0.03<br>0.015-0.04<br>0.02-0.05<br>0.03-0.055                              | 8.340x10 <sup>-7</sup><br>1.390x10 <sup>-6</sup><br>4.170x10 <sup>-6</sup><br>9.730x10 <sup>-6</sup><br>1.446x10 <sup>-5</sup><br>3.948x10 <sup>-5</sup>   | 1.0 - 1.5 million metres                 | 3.8 - 5.0 million metres                 |
| LAK8<br>LAK10   | 0.01-0.02<br>0.01-0.02   | 1.390x10 <sup>-6</sup><br>4.170x10 <sup>-6</sup>   | 2.0 - 2.5 million metres                 | 4.5 - 5.8 million metres                 |
| LWD6<br>LWD8<br>LWD10<br>LWD11<br>LWD13                             | 0.03 max<br>0.04 max<br>0.04 max<br>0.06 max<br>0.06 max   | 8.340x10 <sup>-7</sup><br>1.390x10 <sup>-6</sup><br>4.170x10 <sup>-6</sup><br>9.730x10 <sup>-6</sup><br>1.446x10 <sup>-5</sup>   | 2.5 - 3.15 million metres                | 5.0 - 6.35 million metres                |



### Typical Mechanical Properties (continued)

| Leadscrew Series | Static Frictional Drag Torque (Nm) | Screw Inertia<br>Kg m <sup>2</sup> /m | Anti-backlash Life +      |                           |
|------------------|------------------------------------|---------------------------------------|---------------------------|---------------------------|
|                  |                                    |                                       | Plain Screw               | TFE Coated Screw          |
| LNTB6            | 0.004-0.01                         | 8.340x10 <sup>-7</sup>                | 2.5 - 3.15 million metres | 5.0 - 6.35 million metres |
| LNTB8            | 0.01-0.02                          | 1.390x10 <sup>-6</sup>                |                           |                           |
| LNTB10           | 0.01-0.02                          | 4.170x10 <sup>-6</sup>                |                           |                           |
| LNTB11           | 0.01-0.02                          | 9.730x10 <sup>-6</sup>                |                           |                           |
| LNTB13           | 0.015-0.04                         | 1.446x10 <sup>-5</sup>                |                           |                           |
| LNTB16           | 0.015-0.04                         | 3.948x10 <sup>-5</sup>                |                           |                           |
| LNTB19           | 0.02-0.05                          | 8.479x10 <sup>-5</sup>                |                           |                           |
| LNTB22           | 0.03-0.06                          | 1.612x10 <sup>-4</sup>                |                           |                           |
| LNTB24           | 0.03-0.06                          | 2.030x10 <sup>-4</sup>                |                           |                           |
| LCM6             | 0.03                               | 8.340x10 <sup>-7</sup>                | 1.0 - 1.5 million metres  | 3.8 - 5.0 million metres  |
| LCM8             | 0.04                               | 1.390x10 <sup>-6</sup>                |                           |                           |
| LCM10            | 0.04                               | 4.170x10 <sup>-6</sup>                |                           |                           |
| LAX13            | 0.015-0.04                         | 1.446x10 <sup>-5</sup>                | 5.0 - 5.7 million metres  | 7.6 - 8.8 million metres  |
| LAX16            | 0.015-0.04                         | 3.948x10 <sup>-5</sup>                |                           |                           |

+ Life will vary with loading, operating environment and duty cycle.  
Longer screw leads generally give longer life.

#### TFE COATED LEADSCREW ASSEMBLIES

The TFE coating is designed to supply a more even distribution of lubricant than is normally achieved when using standard self lubricating plastics on steel. The entire screw surface is coated which gives an extremely even lubrication distribution and an expected increase in normal nut life of up to 300%. Lubrication to the screw/nut interface occurs by the nut picking up TFE particles from the coating as well as from migration of the internal lubricant from within the plastic nut.

Although care should be taken to ensure that chips and voids do not occur in the coating, small voids have been shown to have little effect on the system performance. The lubricant, although solid, has some of the "spreading" ability of fluid lubricants. When machining for bearing ends, soft fixtures are recommended.

TFE coated screws provide the maximum level of self-lubrication and should not be additionally lubricated or used in environments where oils or other lubricant contamination is possible.





## TORSIONAL STIFFNESS

This is the characteristic that describes the angular deflection when a torque is applied. High torsional stiffness contributes to increased accuracy and system response. It is essential for accurate feedback applications. Applications that are subject to shock loads may require a less stiff coupling to reduce the peak torques and avoid premature failure or slipping clamps.

Test samples are standard products with a nominal O.D of 20 mm

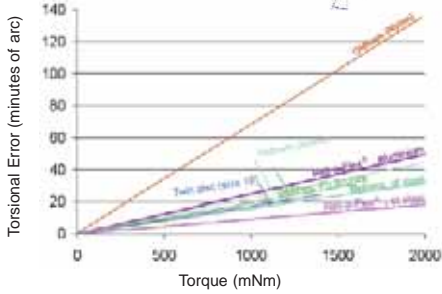

## RADIAL COMPLIANCE

This is the characteristic that describes the force the coupling applies on the support bearings when the shafts are misaligned. High radial compliance is essential to provide low bearing loads.

Test samples are standard products with a nominal O.D of 20 mm

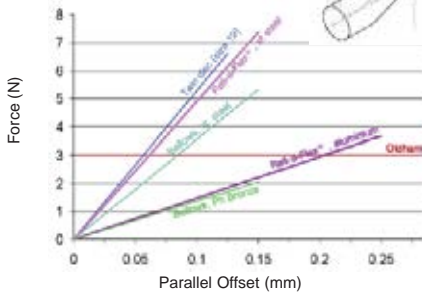

## TORQUE CAPACITY

In general, the rated torque figures are based on  $>10^6$  torque reversals and the peak torque should not be applied for more than 1% of the duty cycle.

## SHAFT MISALIGNMENT

The most common type of misalignment is a combination of angular, parallel and axial misalignment and occurs due to the build-up of tolerances as associated parts are assembled together. As these accumulate randomly, worst-case misalignment should be calculated and used to select the correct coupling to avoid premature failure.

### Angular



### Parallel



### Axial

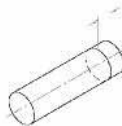

### Combined





## TRANSMISSION ERROR

Often referred to as kinematic error, this is the total error in the driven shaft position with regard to the driving shaft position. In a system the following factors must be individually considered to determine their overall effect.

- a. Backlash ..... internal clearance related
- b. Torsional wind up ..... torsional stiffness related
- c. Velocity error ..... coupling design related

### a. Backlash

Is the amount of free rotational movement inherent in the coupling under zero or near zero torsional loads. Only the Oldham coupling type in this catalogue is susceptible to slight backlash.

### b. Torsional Wind Up

In applications where the resistance is frictional, the driven shaft will experience a position lag, which will double with direction reversal, proportional to the torsional stiffness.

During operating mode, the inertia and the torque will cause a momentary lag but this will not be seen at standstill.

### c. Velocity Error

In general, couplings with double flexing elements (Reli-a-Flex®, Bellows and Twin disc couplings) will introduce negligible velocity errors.

Velocity errors occur with angular misalignment and are proportional to shaft angle. Only the Oldham coupling type in this catalogue is susceptible to this error.

## LUBRICATION

This is not required on any of the couplings in this catalogue.

## FLOATING SHAFTS

We do not recommend the use of couplings in this catalogue for floating shafts, where one or both ends of a shaft are supported by a coupling.

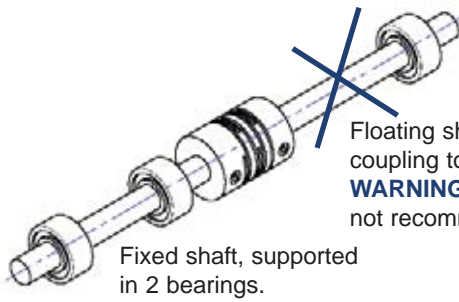



## TORSIONAL RESONANCE

The torsional natural frequencies of a system are dependent on the mass/elastic characteristics of the various inertias and connecting shafts. Torsional resonance can occur under certain conditions when the natural frequency of the system is close to the excitation frequency of the driving system. It is most likely to occur when the load is predominantly inertial and can occur in closed loop position or velocity control systems, leading to torsional vibrations which in severe circumstances can destroy the coupling.

Choosing a coupling that operates well above or well below the operating frequencies can help to avoid premature failure.

The resonant frequency of a system can be calculated from the following:

$$F_R = 1/2\pi \times \sqrt{(1/J_M + 1/J_L) \times 10.8/\pi \times C_T}$$

where

- $F_R$  = Resonant frequency (Hz)
- $J_M$  = Motor inertia (Kgm<sup>2</sup>)
- $J_L$  = Load inertia (Kgm<sup>2</sup>)
- $C_T$  = Coupling torsional stiffness (mNm/min)

## RELI-A-FLEX® INSTALLATION

Couplings are available with either clamp or set screw mounting. Clamp fastening, both Reli-a-Grip™ and traditional, allows repeated repositioning of the coupling on the shaft leaving the shaft unmarked. The effectiveness of the clamp is dependent on the diameter being a 'close' fit in the coupling bore. Use of Reliance components will ensure that the clamp works correctly.

Set screws provide an effective but non-adjustable means of connecting couplings and shafts. Ideally the shafts should have a small flat in the area of the screw, which allows the set screw to seat below the surface of the shaft.

## OLDHAM COUPLING, SOLID COUPLING AND COLLAR INSTALLATION

### Oldham Couplings

Ensure that the misalignment between shafts is within the coupling's ratings. Slide a hub onto each shaft to be joined with the drive tenons facing each other. Rotate the hubs on the shaft so the drive tenons are located 90° from each other. Place a torque disc so one groove fits over the drive tenons of a hub and centre the disc by hand.

Insert a shim with the thickness of the coupling's axial motion rating into the groove of the torque disc. Slide the tenons of the second hub into the mating groove in the disc until it touches the shim stock.

Fully tighten the screw(s) on each hub to their recommended seating torque. Remove the shim stock to leave a small gap between the top of the drive tenons and the torque disc to allow for axial movement.



## Solid Couplings

Align the coupling on the two shafts to be connected. Tighten the Nypatch® clamp screws in two stages. Starting with the inside screws, tighten to half of the recommended seating torque. Repeat for the outside screws, again tightening to half of the recommended seating torque (on two-piece collars be sure to maintain the gap between the two halves of the coupling during installation). Tighten screws to the full recommended seating torque following the same pattern, beginning with the inside screws.

## Collars

Use collars as they are received.

Wipe the bore clean and apply a thin coat of light oil to the shaft. Place collar in desired location on shaft and tighten the collar until a slight resistance is felt (on two-piece collars be sure to maintain the gap between the two halves of the collar during installation). Bring collar into final position and tighten screws to the full recommended seating torque.



## FEATURES

The Reliance range of precision slides includes both ball and crossed roller units. Load capacities from 1.5 to 12580 N are available. Ballslides are available in both stainless steel and aluminium. Crossed roller slides are available in aluminium only. These units offer the designer:

- Pre-assembled units allowing quick and simple assembly.
- Factory set preload to prevent side play and backlash and to control friction.
- Low particle production for use in clean/medical environments.
- Low inertia and light weight allowing low powered rapid traverse.
- High straight line accuracy of 0.0001 mm per mm travel.

### 1. Ballslides

Manufactured from aluminium, these slide units offer ultra low friction, high load capacity and long life. The base and slide are ready machined for mounting. Modifications may be made to suit special requirements. Complete special slides can also be supplied. Please contact us.

### 2. Crossed Roller Slides

When compared to ballslides these units offer equal size but higher load capacity and accuracy. They are also able to operate with high cycling rates and higher shock or cantilevered loads.

### 3. Rack Driven Ball Slides

The addition of a small high precision rack along the side of a ballslide offers the option either to drive, measure position, or both, at very high speeds and loads.

## ENGINEERING DATA

For the highest accuracy, the load should be centred over the table or bed, allowing enough additional length to avoid reaching the maximum stroke length. To achieve the expected accuracy and life, the mating surfaces used to mount the slide should be flat. In extreme circumstances 'potting' of the base may be required.

Please refer to the product dimensions when selecting the fixings to avoid contact between screws and moving slide sections.

### 1. Vertical Applications

When using ball or crossed roller type slides in vertical applications, the position and manner of the load, and the effects of gravity should be given extra consideration. Limiting the travel with positive stops also extends life instead of relying on the ball or roller retainer to act as a stop.

### 2. Service Life

The theoretical service life of a slide based on  $L_{10}$  life is as follows:

Ballslides

$$L_{10} = (C/P)^3 \times 50 \times 10^3$$

Crossed roller slides

$$L_{10} = (C/P)^{10/3} \times 50 \times 10^3$$

Where :

- $L_{10}$  = Life at 90% reliability (m)
- $C$  = Dynamic load rating (N)
- $P$  = Calculated load (N)



### 3. Lubrication

All types of slides can use similar lubricants but require them under different conditions.

#### Recommended Lubricants

#### General Application

- High quality turbine oil
- Lithium soap based grease (NLGI No. 2)

#### Clean Environments

- Kluber Isoflex Topas NCA 52

### 4. Temperature Limits

The maximum temperature is limited to 65°C (150°F) by the rolling element retainers. High temperature retainers can be supplied to operate up to 100°C (212°F) and although the slides can operate at higher temperatures this will reduce their life. Please contact us for further details.

## MINIATURE STROKE SLIDES

### 1. Rating Life Calculation and Short Stroke Factor Diagram

$$L = K_{st} \left( \frac{C_{100B}}{P} \right)^3 \cdot 10^5$$

$$L_h = \frac{L}{2 \cdot s \cdot n \cdot 60} = K_{st} \frac{L}{v_m} \cdot \left( \frac{C_{100B}}{P} \right)^3$$

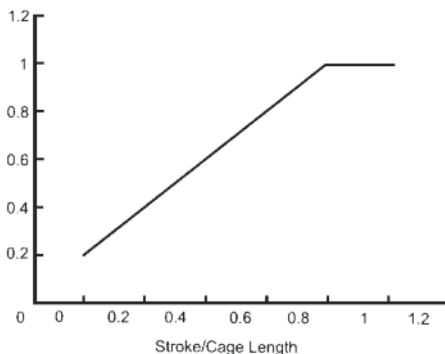

### 2. Rating Life L

The rating life of the RST miniature stroke slide series can be calculated by using the formulae above, in accordance with ISO 14728-1.

### 3. Lubrication

The lubrication of the RST miniature stroke slide series can be fulfilled by directly adding the lubricant onto the raceway of the rail.



### MINIATURE LINEAR GUIDES

#### 1. Rail Butt-Jointing

When a longer rail is required than the maximum standard length available, two or more rails can be butt-jointed to create the desired length. When ordering add a -J to the end of the part number.

To ensure that the rails are mounted in an accurate and consistent manner they will be marked up as a matching pair when manufactured. The marking system for a rail that has been ordered as a -J to be butt-jointed is shown below, where matching pairs have the same marking.

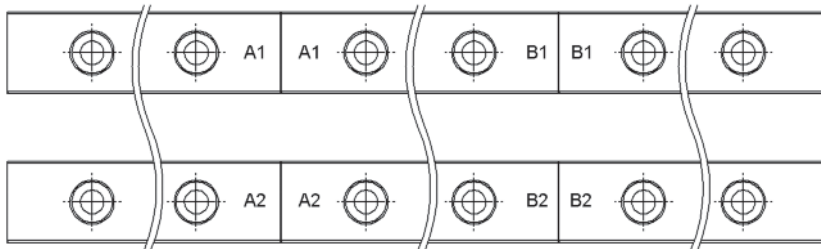

#### 2. Accuracy

Miniature Linear Guides are available in three accuracy grades P, H and N.

| Accuracy classes ( $\mu\text{m}$ )  |              | Precision P | High H   | Normal N |
|---|--------------|-------------|----------|----------|
| Tolerance of dimension height H   | H            | $\pm 10$    | $\pm 20$ | $\pm 40$ |
| Variation of height for different runner block on the same position of rail | $\Delta H$   | 7           | 15       | 25       |
| Tolerance of dimension width W  | $W_2$        | $\pm 15$    | $\pm 25$ | $\pm 40$ |
| Variation of width for different runner block on the same position of rail  | $\Delta W_2$ | 10          | 20       | 30       |

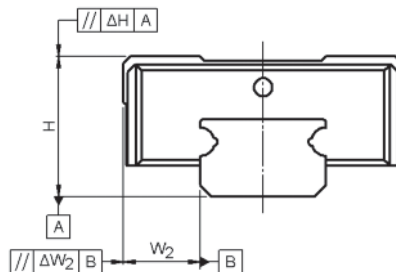



### 3. Speed

For the SS/ZZ variant:

Maximum speed:  $V_{max} = 3 \text{ m/s}$

Maximum acceleration:  $a_{max} = 250 \text{ m/s}^2$  (If preload V0, maximum acceleration is 40 m/s<sup>2</sup>)

For the EE/EU/UZ variant:

Maximum speed:  $V_{max} = >5 \text{ m/s}$

Maximum acceleration:  $a_{max} = 300 \text{ m/s}^2$  (If preload V0, maximum acceleration is 60 m/s<sup>2</sup>)

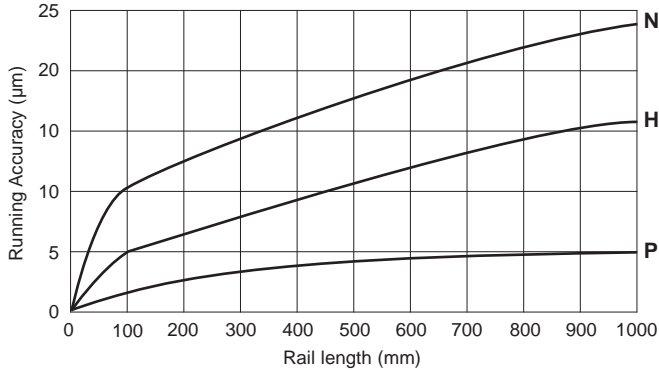

### 4. Pre-load

Miniature Linear Guides are available in three different grades of pre-load V0, VS and V1. The amount of pre-load can enhance stiffness, precision and torsional resistance but affects life and friction.

| Pre-load Type  | Model Code | Clearance (µm) |         |         |         |         |         | Application  |
|----------------|------------|----------------|---------|---------|---------|---------|---------|--|
|                |            | 3              | 5       | 7       | 9       | 12      | 15      |  |
| Clearance      | V0         | +3 to 0        | +3 to 0 | +4 to 0 | +4 to 0 | +5 to 0 | +6 to 0 | Very smooth  |
| Standard       | VS         | +1 to 0        | +1 to 0 | +2 to 0 | +2 to 0 | +2 to 0 | +3 to 0 | Smooth Precision   |
| Light Pre-load | V1         | 0 to -0.5      | 0 to -1 | 0 to -3 | 0 to -4 | 0 to -5 | 0 to -6 | High rigidity<br>Minimal vibration<br>High precision<br>Load balance |

### 5. Operating Temperature

Miniature Linear Guides can operate in temperatures ranging from -40°C to +80°C. Temperatures of 100°C can be reached for short term operation.





## INTRODUCTION

Timing belts are endless toothed belt systems available in 2.5 mm and 5 mm pitch; intended for applications requiring a level of power transmission.

## ENGINEERING DATA

### 1. Belt and Chain Length

Knowing the centre distance, the belt length can be calculated from the following:

For ratios = 1:1 
$$L_B = Z_1 \times t + 2a \quad [\text{mm}]$$

For ratios  $\neq$  1:1  
(approximate formula) 
$$L_B \approx \frac{t}{2}(Z_2 + Z_1) + 2a + \frac{1}{4a} \left[ \frac{(Z_2 - Z_1)t}{\pi} \right]^2 \quad [\text{mm}]$$

- |       |   |                             |       |   |                                    |
|-------|---|-----------------------------|-------|---|------------------------------------|
| a     | = | Centre distance             | t     | = | Belt pitch                         |
| $L_B$ | = | Belt length                 | $d_2$ | = | Pitch circle diameter large pulley |
| $d_1$ | = | Pitch diameter small pulley | $Z_2$ | = | No of teeth, large pulley          |
| $Z_1$ | = | No of teeth, small pulley   | $Z_e$ | = | No of teeth in mesh                |
| $Z_B$ | = | No of teeth in belt         |       |   |                                    |

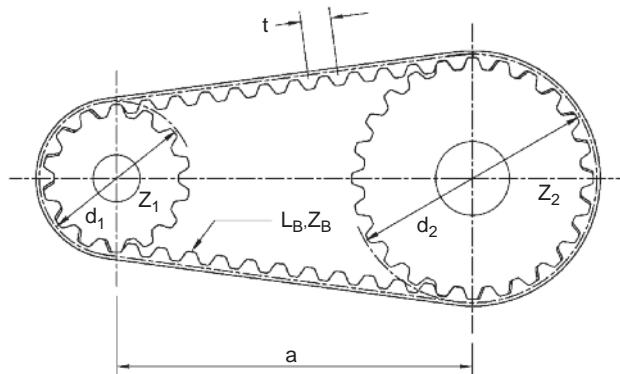

Technical  
Information



## 2. Centre Distance Calculation

Knowing the belt length, the centre distance can be calculated from the following;

For ratios = 1:1 
$$a = \frac{(Z_B - Z_1)t}{2} \quad [\text{mm}]$$

For ratios  $\neq$  1:1  
(approximate formula)

$$a \approx \frac{L_B - \frac{\pi}{2} \times (d_2 + d_1)}{4} + \sqrt{\left( \frac{L_B - \frac{\pi}{2} \times (d_2 + d_1)}{4} \right)^2 - \frac{(d_2 - d_1)^2}{8}} \quad [\text{mm}]$$

$$d_1 = \frac{Z_1 \times t}{\pi} \quad [\text{mm}] \quad d_2 = \frac{Z_2 \times t}{\pi} \quad [\text{mm}]$$

## 3. Design Guidelines

Timing belt efficiency ranges from 95 to 98%, better than flat vee belts which rely on friction to transmit power. The 2.5 mm and 5 mm pitch timing belts are manufactured in wear resistant polyurethane with high grade steel wire tension members, therefore any elongation due to load and pre-tension will follow Hookes' law. The manufacturing process for these timing belts produces the 'classical' trapezoidal tooth form to close tolerances. This ensures an even distribution of load during use and the transmission of high torques. These belts are suitable for indexing, positioning and conveying drives.

It is possible to design drives with fixed centres but generally the drive centres should be adjustable or have idler pulleys. This is particularly important in multi-shaft or high power drives. The idler pulleys should be fitted to the slack side of the drive and must not be spring loaded. Timing belt drives do not require as much tension as other belt drives which depend on friction to transmit load. The belt should be installed with a snug fit, neither taut nor loose. As a general guide the correct level of tension can be determined by measuring the force necessary to deflect the belt an amount equal to 1/64th of the span centres "a". Values for the measuring force recorded on a spring balance applied mid-span should be within 20% of the values shown below.

2.5 mm - 0.07kg      5 mm - 0.30kg

The belts must be rigidly mounted. Variation in centre distance can lead to premature wear. The belt and pulley system must be assembled loose to prevent over stretching. The belts are guided on the pulleys by flanges. One pulley should be flanged on both sides, or two alternative flanges provided, one on each pulley. For drives with vertical shafts, both pulleys should be flanged on both sides.

For a belt to transmit full power, a minimum of 6 teeth must be in mesh on each pulley. The number of teeth in mesh can be determined from the following formula:

$$Z_e = \frac{Z_1}{180} * \text{arc cos} \frac{(Z_2 - Z_1) \times t}{2 \pi a}$$

Number of teeth in mesh calculation is always based on the smallest pulley.

To minimise belt fatigue, pulleys with a minimum of 20 teeth are recommended. As a general guide larger pulleys reduce the amount of belt flexing and therefore improve belt life.



### SPECIFICATION

The first step in choosing the correct bearing for an application is to determine the forces which it will support in service. The forces will depend on the exact configuration of the system and will probably include some, or all, of the following:

- The weight of the shaft, including gears and other shaft attachments.
- Gear mesh reaction forces, due to torque transmission (see below).
- Gear separation due to anti-backlash forces.
- Forces due to belt or pulley tensions.
- Axial pre-load forces.

### GEAR MESH REACTIONS

In order to calculate the loads which will be applied to the bearings in the simply supported spur gear pass arrangement shown on the next page, it is first necessary to calculate the forces at the gear mesh.

The tangential force at the gear mesh can be calculated from the following equation:

$$W_t = T/r \quad \text{where } T = \text{Torque} \\ \text{and } r = \text{Radius}$$

and the separating force at the gear mesh can be calculated from:

$$W_r' = W_t \tan \phi_t \quad \text{where } \phi_t = \text{transverse pressure angle} \\ = \text{normal pressure angle for spur gears} \\ = 20^\circ \text{ for our standard gears}$$

$$W_r' = 0.364W_t \quad (\text{for } 20^\circ \text{ pressure angle spur gear})$$

If required, the total radial load at the gear mesh can be calculated from the final equation:

$$W_r = \sqrt{(W_t)^2 + (W_r')^2}$$

Bearing loads

| Position  | Forces At These Positions    |                               |   |
|-----------|------------------------------|-------------------------------|---|
|           | Tangential Force             | Separating Force              | Total Radial Load                         |
| Gear Mesh | $W_t$                        | $W_r'$                        | $W_r$                                     |
| Bearing A | $W_{t1} = \frac{W_t a}{a+b}$ | $W_{r2} = \frac{W_r' a}{a+b}$ | $W_{rA} = \sqrt{(W_{t1})^2 + (W_{r2})^2}$ |
| Bearing B | $W_{t3} = \frac{W_t b}{a+b}$ | $W_{r4} = \frac{W_r' b}{a+b}$ | $W_{rB} = \sqrt{(W_{t3})^2 + (W_{r4})^2}$ |
| Bearing C | $W_{t5} = \frac{W_t c}{c+d}$ | $W_{r6} = \frac{W_r' c}{c+d}$ | $W_{rC} = \sqrt{(W_{t5})^2 + (W_{r6})^2}$ |
| Bearing D | $W_{t7} = \frac{W_t d}{c+d}$ | $W_{r8} = \frac{W_r' d}{c+d}$ | $W_{rD} = \sqrt{(W_{t7})^2 + (W_{r8})^2}$ |



For bearing life calculations based on these radial loads see page T12-3.

Note - These equations can only be used for spur gear calculations, because they are not affected by self-generated axial forces.

Bearing loads and gear mesh forces diagram

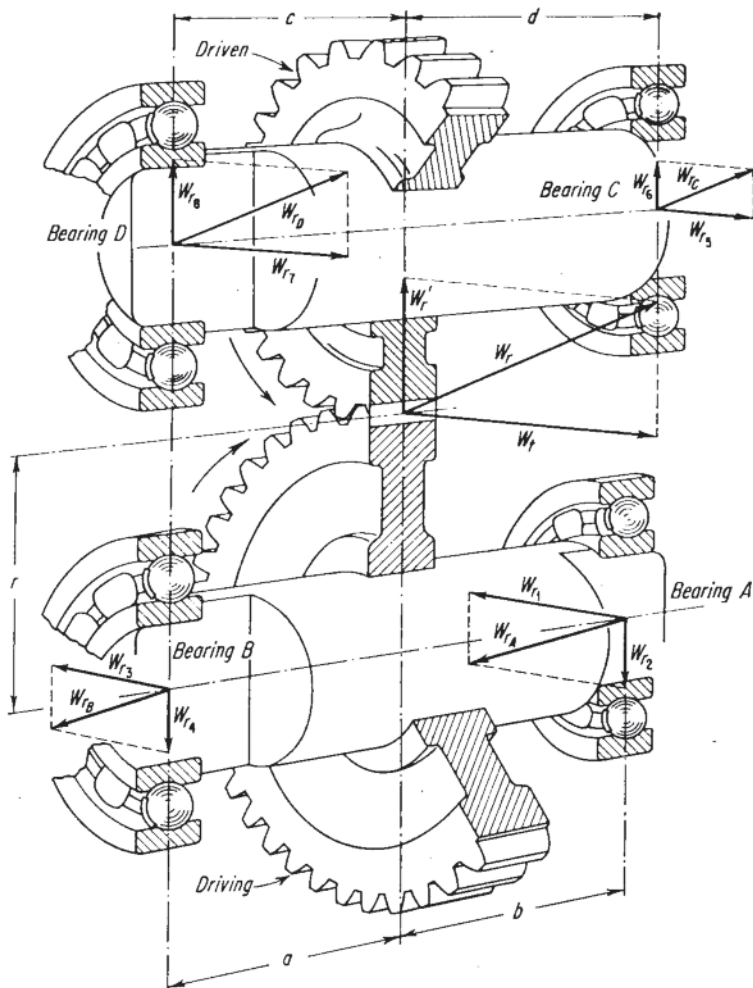



## FORCE SHARING

To determine how the forces are shared between a pair of bearings, use the equations below for these two most frequently occurring configurations:

### 1. Radial Shaft Load Between Two Bearings

Loads are in constant units

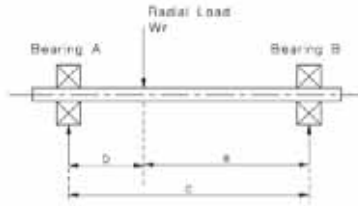

$$\text{Radial load on bearing A} = \frac{W_r * a}{c}$$

$$\text{Radial load on bearing B} = \frac{W_r * b}{c}$$

### 2. Overhung Radial Load

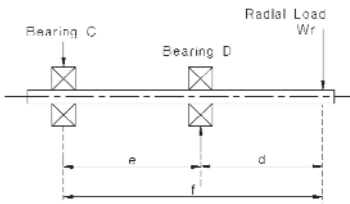

$$\text{Radial load on bearing C} = \frac{W_r * d}{e}$$

$$\text{Radial load on bearing D} = \frac{W_r * f}{e}$$

The individual bearing loads can then be used to predict the bearing life.

## BEARING LIFE

The life of a bearing is defined as the length of time a bearing will operate satisfactorily in the application at its operating speed under applied load. Life predictions depend on a careful definition of failure criteria and consideration of operating environment, mounting practice, lubrication, operating speed and loading. As a guide, the relationship between actual applied load and bearing fatigue life is given below:

$$L_H = \frac{16667}{N} \left( \frac{C}{P} \right)^3$$

$L_H$  = Rated life in hours

$N$  = Speed in rpm

$P$  = Bearing load (e.g. N)

$C$  = Bearing capacity (e.g. N)



## INSTALLATION AND HOUSING CONSIDERATIONS

The installation of a bearing will usually be determined by how it fits with its mating components. Interference or transition fits provide the most positive location of the bearing, however, they will require pressing during installation. Clearance fits allow the bearing to be assembled very easily, but could potentially lead to problems depending on the operating conditions. If a press fit is required, it is essential that no appreciable force is transferred through the rolling elements of the bearing during installation.

Special care must be taken when using bearings in aluminium housings, especially when wide temperature variations are expected. It is possible for the contraction of the housing to squash the bearing raceway and remove the radial clearance required for the bearing to operate.

Potential problems with clearance fits:

Fretting - Wearing away of the surface due to rubbing of the components.

Accuracy - Accuracy can be compromised due to unpredictable movement.

Potential problems with interference fits:

Assembly - Can be difficult or impossible without damaging the bearing.

Radial clearance - Can be reduced if the interference is too great.



## ISO METRIC SCREW THREADS: LIMITS AND TOLERANCES

| Thread | Pitch | Internal/<br>External<br>Tol. Class | Major Diameter |       |        | Pitch Diameter |       |       | Minor Diameter |       |       |
|--------|-------|-------------------------------------|----------------|-------|--------|----------------|-------|-------|----------------|-------|-------|
|        |       |                                     | max            | tol   | min    | max            | tol   | min   | max            | tol   | min   |
| M1.6   | 0.35  | 6g (screw)                          | 1.581          | 0.085 | 1.496  | 1.354          | 0.063 | 1.291 | -              | -     | 1.075 |
|        |       | 6H (nut)                            | -              | -     | 1.600  | 1.458          | 0.085 | 1.373 | 1.321          | 0.100 | 1.221 |
| M2     | 0.40  | 6g                                  | 1.981          | 0.095 | 1.886  | 1.721          | 0.067 | 1.654 | -              | -     | 1.408 |
|        |       | 6H                                  | -              | -     | 2.000  | 1.830          | 0.090 | 1.740 | 1.679          | 0.112 | 1.567 |
| M2.5   | 0.45  | 6g                                  | 2.480          | 0.100 | 2.380  | 2.188          | 0.071 | 2.117 | -              | -     | 1.839 |
|        |       | 6H                                  | -              | -     | 2.500  | 2.303          | 0.095 | 2.208 | 2.138          | 0.125 | 2.013 |
| M3     | 0.50  | 6g                                  | 2.980          | 0.106 | 2.874  | 2.655          | 0.075 | 2.580 | -              | -     | 2.272 |
|        |       | 6H                                  | -              | -     | 3.000  | 2.775          | 0.100 | 2.675 | 2.599          | 0.140 | 2.459 |
| M4     | 0.70  | 6g                                  | 3.978          | 0.140 | 3.838  | 3.523          | 0.090 | 3.433 | -              | -     | 3.002 |
|        |       | 6H                                  | -              | -     | 4.000  | 3.663          | 0.118 | 3.545 | 3.422          | 0.180 | 3.242 |
| M5     | 0.80  | 6g                                  | 4.976          | 0.150 | 4.826  | 4.456          | 0.095 | 4.361 | -              | -     | 3.868 |
|        |       | 6H                                  | -              | -     | 5.000  | 4.605          | 0.125 | 4.480 | 4.334          | 0.200 | 4.134 |
| M6     | 1.00  | 6g                                  | 5.974          | 0.180 | 5.794  | 5.324          | 0.112 | 5.212 | -              | -     | 4.597 |
|        |       | 6H                                  | -              | -     | 6.000  | 5.500          | 0.150 | 5.350 | 5.153          | 0.236 | 4.917 |
| M8     | 1.25  | 6g                                  | 7.972          | 0.212 | 7.760  | 7.160          | 0.118 | 7.042 | -              | -     | 6.272 |
|        |       | 6H                                  | -              | -     | 8.000  | 7.348          | 0.160 | 7.188 | 6.912          | 0.265 | 6.647 |
| M10    | 1.50  | 6g                                  | 9.968          | 0.236 | 9.732  | 8.994          | 0.132 | 8.862 | -              | -     | 7.938 |
|        |       | 6H                                  | -              | -     | 10.000 | 9.206          | 0.180 | 9.026 | 8.676          | 0.300 | 8.376 |

Reference: BS3643 Pt 2, 2007.

## TORQUE AND TENSION GUIDELINES

The usual method for specifying and measuring fastener installation is tightening torque, as this is relatively easy to measure with a torque wrench. Unfortunately, a torque wrench does not give an accurate indication of bolt tension because it does not take friction into account. The friction is dependent on the bolt, nut and washer materials, surface smoothness, machining accuracy, degree of lubrication (including uncured retaining products) and the number of times a fastener has been installed. The torque values provided for the screws in the table below are, therefore, to be used only as a guide, the friction factors mentioned should be considered for each application.

Aluminium structural components assumed, as this is typical of the applications for which the Reliance standard products range is designed for.



| Screw Size | Tightening Torque for 700 MPa Socket Head Cap Screw (Nm) | Tightening Torque for Stainless Steel Set Screws (Nm) |
|------------|--|---|
| M1.6       | 0.13   | 0.05  |
| M2         | 0.26   | 0.05  |
| M2.5       | 0.52   | 0.18  |
| M3         | 0.92   | 0.32  |
| M4         | 2.10   | 0.75  |
| M5         | 4.20   | 1.50  |



## RELIANCE STANDARD MATERIALS

Reliance Precision screws are manufactured from the materials listed below. Where the product material is specified, we reserve the right to change the actual material to an equivalent specification without notice depending on availability.

| Material Grade | Treatment             | Grain Structure | Tensile Strength MPa (min) | Corrosion Resistance |
|----------------|-----------------------|-----------------|----------------------------|----------------------|
| A2-70          | n/a                   | Austenitic      | 700                        | Excellent            |
| A4-70          | n/a                   | Austenitic      | 700                        | Excellent            |
| 303            | n/a                   | Austenitic      | 585                        | Excellent            |
| 416            | Hardened to 26/32 HRC | Martensitic     | 880                        | Good                 |

### General Properties of Austenitic Stainless Steels

- Excellent resistance to oxidation and corrosion.
- Essentially non-magnetic.
- Cannot be hardened by heat-treatment.
- Work hardened very easily.
- Relatively high coefficient of thermal expansion of 18 microns/metre/°C, close to that of aluminium.

### General Properties of Martensitic Stainless Steels

- Good resistance to oxidation and corrosion.
- Magnetic.
- Readily heat treatable to high strength condition.
- Potential for tensile strengths > 1200 MPa.
- Coefficient of thermal expansion of approximately 11 microns/metre/°C.







Reliance Precision Limited

Home Account Help Us 1800 63 1000

### Components and Assemblies

Precision Components & Online Store

### Precision Assemblies

Range Description

|  |   |   |
|--|---|---|
| <br>Precision Shafts<br>Buy     | <br>Precision Couplings<br>Buy | <br>Motorized Rack Actuators<br>Info |
| <br>Bearings & Springs<br>Buy   | <br>Screws & Hardware<br>Buy   | <br>Motors & Cables<br>Info          |
| <br>Shafts & Accessories<br>Buy | <br>Bolts & Nuts<br>Buy        | <br>Linear Actuators<br>Info         |

- Online Store
- Precision Shafts
- Precision Couplings
- Motorized Rack Actuators
- Bearing and Springs
- Screws and Fasteners
- Bolt and Nuts
- Quality and Accessories
- Catalogue
- Precision Shafts
- Precision Couplings
- Motorized Rack Actuators
- Bearing and Springs
- Screws and Fasteners
- Bolt and Nuts
- Quality and Accessories

# Section Contents

Location Map.....Page A-2

On-line Store .....Page A-4

Conditions of Sale .....Page A-5

International Sales Representatives.....Page A-6

Index by Part Number .....Page A-7

Index by Product .....Page A-10

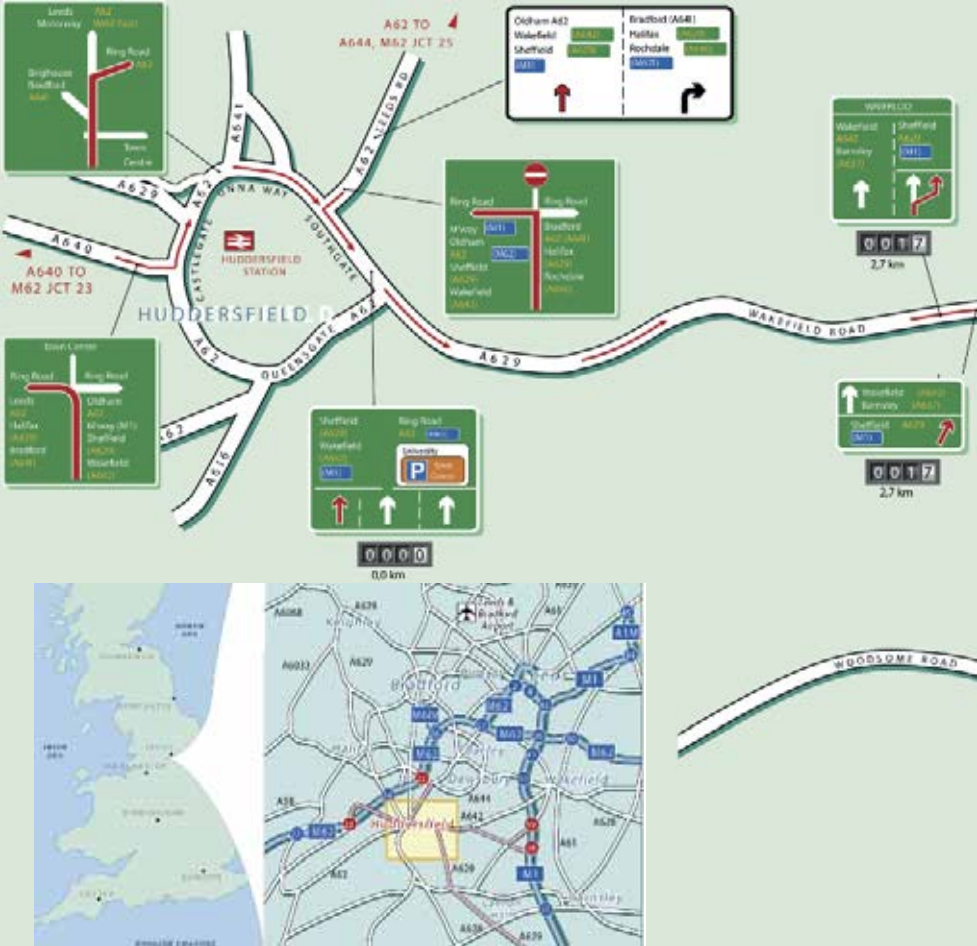

### NORTH & SOUTH APPROACHES

**From the North:** Junction 39 of M1 (Denby Dale turn off), follow the A636 for 3 miles and then turn right on to the A637 for 2 miles. At the next roundabout turn left on to the A642 to Huddersfield. After 1 mile on the A642 turn left through the village of Lepton, to join the A629. Turn left and Reliance is 100 yards on the left.

**From the South:** Junction 38 of the M1, follow the A637 for 4.5 miles passing Yorkshire Sculpture Park and straight across at the second roundabout on to the A642 to Huddersfield.

or

Junction 35A M1, follow the A616 for 3 miles, turn off onto the A629 towards Huddersfield. Follow this road for approximately 15 miles, passing through Thurgoland, Ingbirchworth and Shepley. Reliance is on the right.



## EAST & WEST APPROACHES

**From the East:** Junction 25 of M62, follow the A644 for 2 miles and turn right at the next roundabout on to the A62. Follow the A62 for 5 miles until it joins the Huddersfield ring road. Leave the ring road following the A629 for Sheffield (Sainburys supermarket on your left). Follow the A629 for 3.4 miles. Reliance is on the left.

**From the West:** Junction 23 of the M62 (or J25 and follow as above), follow the A640 for 3 miles to Huddersfield ring road. Turn right on to the ring road. Follow the ring road for approximately 3/4 miles ignoring the signs for Sheffield (A616) and Manchester (A62) until you pass the University. Turn right at the next roundabout onto the A629, sign posted to Sheffield and Wakefield. Follow the A629 for 3.4 miles. Reliance is on the left.

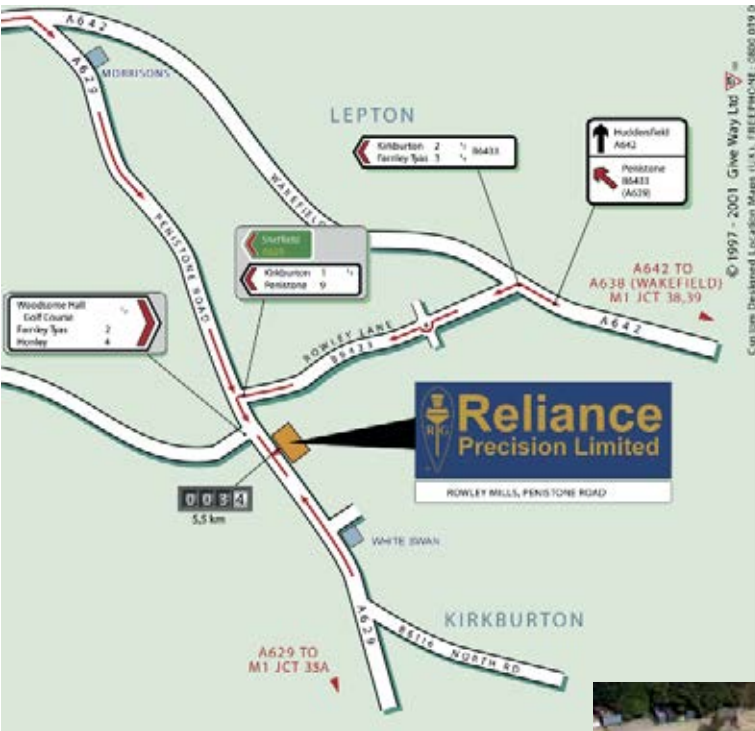

Appendices and Index

### Public Transport



#### Wakefield Station

25 minutes by taxi

#### Huddersfield Station

20 minutes by taxi



#### Manchester Airport

1 hour by road

#### Leeds/Bradford Airport

1 hour by road





## Making a purchase on-line

Information about Reliance's products and services are available on our website [www.reliance.co.uk/shop](http://www.reliance.co.uk/shop). Many of our catalogue components are available to purchase on-line including:

- Gears
- Couplings
- Bearings and spacers
- Screws and hardware
- Belts and pulleys
- Shafts and accessories



The on-line store is available to customers in the UK, Europe and the US and accepts payments in sterling, euro and dollars, using a secure checkout.

## Creating a custom gear on-line

The on-line custom gear builder gives simple, efficient access to a range of over 300,000 precision gears. Not only does it allow a customised gear to be purchased quickly but it also reduces the risk of the wrong gear being selected. At the end of the on-line selection process all the required technical and commercial information is provided appropriate to the gear specification, including a 3D image, drawing, part description and item number, together with the price and delivery lead time.



There are an extensive number of possible combinations offered, with a wide choice of gears and associated variables in specification - including choice of material, gear module, number of teeth, bore diameter and face width. The on-line gear builder uses a filtering process to seamlessly remove redundant options to enable a swift selection of the required gear. Selections can be amended at any point simply by navigating backwards and forwards through the various steps.

## 3D models available to download

A selection of 3D models is available to download directly from the on-line store, alternatively please contact us and our sales and applications engineering team will be happy to provide them. We are able to provide Step and IGES models.



# Conditions of Sale



In addition to these conditions of sale, our standard Conditions of Sale also apply. A copy of these is available on request and from our website [www.reliance.co.uk/en/help](http://www.reliance.co.uk/en/help)

**Minimum order charge** - Orders are subject to a minimum order charge of £250.00.

**Carriage and packing** - Additional charges are made for carriage and packing.

**Payment** - Payment terms are 30 days. New customers are requested to complete an application form for a credit account. Customers who do not have a credit account with Reliance are requested to supply cheque with order. In addition, orders may be paid for by Visa and Mastercard.

**Telephone orders** - An order number must be quoted by the customer. We reserve the right to supply parts against a telephone order. All telephone orders are accepted subject to these conditions of sale and those detailed on the acknowledgement of order. An acknowledgement will normally be sent by Reliance and goods will be supplied in accordance with the order acknowledgement.

**Certificates of Conformance** - Reliance's quality management system is certified to AS9100 and ISO 9001. A Certificate of Conformance can be supplied at an additional charge of £10.00 per delivery. Alternatively, a Certificate with full material traceability can be supplied at a charge of £20.00 per delivery.

**Confirmation** - All orders, other than telephone orders with a value of less than £500 and orders placed through our website, are subject to acceptance in writing by Reliance Precision Limited.

**Order amendments** - Order amendments are subject to our approval and a charge will be made for reasonable compensation for any costs incurred.

**Returns** - Unused items may, solely at our discretion, be accepted for credit within 90 days of delivery. Any parts so accepted will be subject to a 20% service charge for re-inspection and handling. No credit can be allowed after the above period, or for any used or modified part, or for parts manufactured to a customer's specification.

**Additional charges** - Reliance reserves the right to charge for all additional expenses and taxes incurred over and above published prices (including without limitation duty, VAT, exchange rate fluctuations etc.)

**Alterations** - As a result of continuous product development, Reliance reserves the right to alter prices and other details without prior notice and to change dimensions where this does not affect the function of the item.

## Contact details:

Telephone: +44(0)1484 601002

Email: [sales@reliance.co.uk](mailto:sales@reliance.co.uk)



# International Sales Representatives

## Benelux, Denmark, Austria, Germany, Switzerland

**Reliance Holland** Florijnstraat 20, 4879 AH Etten-Leur, The Netherlands.

Tel: +31 (0) 76 5040790 Fax: +31 (0) 76 5040791 e-mail: sales@reliance.co.uk website: www.relianceprecision.nl

## Sweden

**DJ Stork Drives AB** Vretenvägen 4, ltr, PO Box 1037, SE-172 21 Sundbyberg Sweden.

Tel: +46 (0) 8635 6000 Fax: +46 (0) 8635 6001 e-mail: info@storkdrives.se website: www.storkdrives.se

## Finland

**Wexon OY** Juhanilantie 4, 01740 Vantaa, Finland.

Tel: +358 (0) 9 290440 Fax: +358 (0) 9 29044100 e-mail: wexon@wexon.com website: www.wexon.com

## Slovenia

**PS Logatec d.o.o.** Kalce 38B, 1370 Logatec, Slovenia.

Tel: +386 175 08510 andrejz@ps-log.si website: www.ps-log.si

## Israel

**Medital Hi-tech (1992) Ltd** 7 Leshem Street, PO Box 7772, Petach Tikva 49170, Israel.

Tel: +972 (0) 3 9233323 Fax: +972 (0) 3 9228288 e-mail: hi-tech@medital.co.il website: www.medital.co.il

## South Africa

**Measuring Instruments Technology (MIT)** Rm111, Building 33, CSIR Campus, Meiring Naude Drive, Brammeria 0184, Pretoria,

South Africa. Tel: +27 12 349 5191 Fax: +27 12 348 0564 e-mail: sales@marmit.co.za website: www.marmit.co.za

## China

**EM Components Co Ltd** 665 ZhangJiang Road, Unit 902, ZhangJiang Hi-Tech Park, Shanghai Pudong, PR China 201210

Tel: +86 21 5895 0126 Fax: +86 21 5895 1160 e-mail: sales@emcomponents.com

## Singapore

**Elshin International PTE Ltd** No.1 Kaki Bukit Avenue 3 (KB-1), #06-12 Singapore 416087.

Tel: +65 6286 7707 Fax: +65 6748 2618 e-mail: elshin@singnet.com.sg

## Malaysia

**CMS SUPPLIES Sdn Bhd 46,** (1st Floor) Persiaran Mahsuri 1/2, Sunway Tunas Bayan Baru, 11900 Bayan Lepas Penang, Malaysia

Tel: +604 6446028 Fax: +604 6446082 e-mail: ycng@cmssupplies.com.my

## Korea

**DAIN SEMICOM Inc.** Suite #401, Dooyang Bldg., 273-2, Yatap-dong, Bundang-gu, Seongnam-si, Gyeonggi-do, Korea. (zip. 463-836)

Tel: +82 31 706 8912 Fax: +82 31 706 8916 e-mail: info@dainsemi.co.kr

## Japan

**Isel Co Ltd** 1-2-16 Atobe-kitano-cho, Yao-city, Osaka 581-0068, Japan.

Tel: +81 (0) 7 2991 0450 Fax: +81 (0) 7 2994 7593 e-mail: t\_watanabe@isel.co.jp

## Canada

**Myostat Motion Control Inc** 17817 Leslie Street, Unit 43, Newmarket, Ontario L3Y 8C6, Canada.

Tel: +1 905 836 4441 Fax: +1 905 836 1214 e-mail: chris@coolmuscle.com website: www.myostat.ca

## USA

**The Precision Alliance** 4215 Pleasant Road, Fort Mill, SC 29708 USA.

Tel: +1 (803) 396 5544 Fax: +1 (803) 396 7810 e-mail: info@tpa-us.com website: www.tpa-us.com

## Australia

**Reliance Australia** 65 Macaulay Street, Coorparoo, Brisbane 4151, Queensland, Australia.

Tel: +61 (0) 439 780187 Fax: +61 (0) 738 478670 e-mail: grant@relianceprecision.com.au website: www.relianceprecision.com.au





| Basic Part Number  | Page         | Basic Part Number | Page         |
|--------------------|--------------|-------------------|--------------|
| <b>A</b>           |              | <b>E</b>          |              |
| AC                 | 4-12 to 4-34 | EA                | 9-14 to 9-15 |
| AH                 | 6-11         | EPL               | 12-5         |
| AP                 | 4-13 to 4-35 | ETW               | 13-17        |
| AR                 | 4-7 to 4-11  |                   |              |
| <b>B</b>           |              | <b>F</b>          |              |
| B1                 | 12-2         | F                 | 4-52 to 4-55 |
| B1SU               | 5-13         |                   |              |
| B2                 | 12-2         |                   |              |
| B50B               | 5-14         | G1A               | 5-5          |
| B80B               | 5-14         | G50B              | 5-3          |
| B80SU              | 5-13         | G80A              | 5-4          |
| BBM1               | 12-3         |                   |              |
| BBM2               | 12-3         |                   |              |
| BE                 | 3-22 to 3-23 | HN                | 13-16        |
| BM8                | 12-4         | HY                | 3-16         |
| BM9                | 12-4         |                   |              |
| BS                 | 3-17 to 3-18 |                   |              |
| BSB                | 3-19         | IS50B             | 5-15         |
| BSH                | 3-20 to 3-21 |                   |              |
| BW                 | 13-15        |                   |              |
| <b>C</b>           |              | <b>K</b>          |              |
| C (Clamp hub gear) | 4-36 to 4-50 | K                 | 13-8         |
| C (Machine screws) | 13-10        |                   |              |
| CA                 | 9-14 to 9-15 |                   |              |
| CGAM               | 11-5         |                   |              |
| CGM1               | 11-4         |                   |              |
| CHMD               | 11-7         |                   |              |
| CHM1               | 11-7         |                   |              |
| CSM                | 11-3         |                   |              |
| <b>D</b>           |              | <b>L</b>          |              |
| D (Dowel Pin)      | 13-19        | LAB               | 7-17         |
| D1300              | 13-21        | LABY              | 7-17         |
| D1400              | 13-20        | LAF               | 7-21         |
| DA                 | 9-14 to 9-15 | LAFY              | 7-21         |
|                    |              | LAK               | 7-22         |
|                    |              | LAKY              | 7-22         |
|                    |              | LAX               | 7-25         |
|                    |              | LAXY              | 7-25         |
|                    |              | LBB               | 7-12         |
|                    |              | LBF               | 7-12         |
|                    |              | LBY               | 7-12         |
|                    |              | LCM               | 7-24         |
|                    |              | LCMY              | 7-24         |
|                    |              | LNTBF             | 7-18 & 7-19  |

Appendices and Index

See Pages A-10 to A-16 for Product Index



| Basic Part Number | Page        |
|-------------------|-------------|
| LNTBY             | 7-18 & 7-20 |
| LNTGF             | 7-15 & 7-16 |
| LNTGY             | 7-15 & 7-16 |
| LPX               | 7-13        |
| LPXY              | 7-14        |
| LPXZ              | 7-13        |
| LWD               | 7-23        |
| LWDY              | 7-23        |

**M**

|                     |              |
|---------------------|--------------|
| M04N                | 5-8          |
| M05N                | 5-9          |
| M08N                | 5-10         |
| M1B                 | 5-14         |
| M1SU                | 5-12         |
| M50B                | 5-14         |
| M80B                | 5-14         |
| M80SU               | 5-12         |
| MA                  | 9-14 to 9-15 |
| MCL                 | 8-53         |
| MCLX                | 8-51         |
| MEM                 | 3-26 to 3-27 |
| ML1SU               | 5-11         |
| ML1.5SU             | 5-11         |
| ML80SU              | 5-11         |
| MOCT                | 8-30 to 8-31 |
| MOST                | 8-30 to 8-31 |
| MSC                 | 8-55         |
| MSP (Clamp collars) | 8-53         |
| MSP (Coiled pins)   | 13-18        |
| MSPX                | 8-51         |
| MSS2                | 13-6 to 13-7 |
| MTCL                | 8-54         |
| MWCL                | 8-52         |
| MWSP                | 8-52         |

**N**

|      |              |
|------|--------------|
| NA   | 9-14 to 9-15 |
| NMSS | 13-13        |

| Basic Part Number      | Page         |
|------------------------|--------------|
| ORK                    | 6-7          |
| <b>O</b>               |              |
| <b>P</b>               |              |
| P (Pin hub gear)       | 4-37 to 4-51 |
| P (Hardened spur gear) | 4-56 to 4-59 |
| P (Machine screws)     | 13-9         |
| PHM1                   | 11-6         |
| PHMD                   | 11-6         |
| PW                     | 13-17        |

**R**

|        |              |
|--------|--------------|
| R9     | 6-3          |
| RBKBS  | 8-18         |
| RBKNK  | 8-23         |
| RBKNS  | 8-22         |
| RBKXX  | 8-20 to 8-21 |
| RBKXS  | 8-18 to 8-19 |
| RCL    | 8-8 to 8-15  |
| RCM1   | 2-4 to 2-11  |
| RCMRAK | 2-15 to 2-17 |
| RCMS17 | 2-20 to 2-21 |
| RCMS23 | 2-22 to 2-23 |
| RCS    | 8-8 to 8-15  |
| RDA    | 9-16 to 9-17 |
| REA    | 9-16 to 9-17 |
| RFSKK  | 8-32 to 8-35 |
| RFSXK  | 8-26 to 8-29 |
| RFSXS  | 8-24 to 8-25 |
| RGLS   | 7-38 to 7-39 |
| RGP40  | 3-6 to 3-9   |
| RGP60  | 3-10 to 3-11 |
| RGPN70 | 3-12 to 3-13 |
| RGR    | 9-6          |
| RK     | 6-8 to 6-9   |
| RKKAK  | 8-37         |
| RKKAS  | 8-36         |
| RLRW04 | 2-27         |
| RMR    | 9-8 to 9-11  |

See Pages A-10 to A-16 for Product Index



| Basic Part Number      | Page         | Basic Part Number | Page         |
|------------------------|--------------|-------------------|--------------|
| RMRU                   | 9-8 to 9-11  | SS3               | 12-7         |
| RNA                    | 9-16 to 9-17 |                   |              |
| RR12                   | 6-4          | <b>T</b>          |              |
| RRA                    | 2-15 to 2-16 | TPMP25            | 10-3         |
| RRAK                   | 2-17         | TPMP50            | 10-5         |
| RRKSK                  | 8-47         | TXM25             | 10-2         |
| RRKSS                  | 8-48         | TXM50             | 10-4         |
| RRKTK                  | 8-49         |                   |              |
| RRKTS                  | 8-50         | <b>W</b>          |              |
| RRS                    | 6-5          | W1SU              | 5-5          |
| RRT                    | 6-6          | W50SU             | 5-3          |
| RSA2                   | 9-16 to 9-17 | W80SU             | 5-4          |
| RSKSS                  | 8-46         | WFB               | 5-7          |
| RSM                    | 2-12 to 2-14 | WFS               | 5-7          |
| RSRA                   | 7-40 to 7-41 | WGB               | 5-6          |
| RSRZ                   | 7-42 to 7-43 | WGS               | 5-6          |
| RST12M                 | 9-12 to 9-13 |                   |              |
| RST7M                  | 9-12 to 9-13 | <b>X</b>          |              |
| RST9M                  | 9-12 to 9-13 | XDA               | 9-14 to 9-15 |
| RWKAK                  | 8-42 to 8-43 | XEA               | 9-14 to 9-15 |
| RWKAS                  | 8-38 to 8-41 | XNA               | 9-14 to 9-15 |
| RWKXX                  | 8-45         | XSA1              | 9-14 to 9-15 |
| RWKXS                  | 8-44         | XSA2              | 9-14 to 9-15 |
|                        |              | XSA3              | 9-14 to 9-15 |
| <b>S</b>               |              |                   |              |
| S (Brass gears)        | 4-71 to 4-81 |                   |              |
| S (Socket head screws) | 13-2 to 13-5 |                   |              |
| SA1                    | 9-14 to 9-15 |                   |              |
| SA2                    | 9-14 to 9-15 |                   |              |
| SA3                    | 9-14 to 9-15 |                   |              |
| SG                     | 4-61 to 4-69 |                   |              |
| SGSS                   | 13-12        |                   |              |
| SH                     | 6-10         |                   |              |
| SM1                    | 11-2         |                   |              |
| SM2                    | 11-2         |                   |              |
| SRSS                   | 9-5          |                   |              |
| SQM                    | 13-14        |                   |              |
| SS                     | 13-11        |                   |              |
| SS1                    | 12-6         |                   |              |

See Pages A-10 to A-16 for Product Index



| Product                                      | Page              |
|--|-------------------|
| <b>A</b>                                     |                   |
| Actuator - Anti-backlash ScrewRail® assembly | 7-42 to 7-43      |
| Actuator - Bespoke motorised                 | 2-18              |
| Actuator - Cool Muscle Stage                 | 2-19 to 2-23      |
| Actuator - Hybrid linear                     | 2-24 to 2-25      |
| Actuator - Leadscrew linear slide            | 7-38 to 7-39      |
| Actuator - Linear rail                       | 2-26 to 2-27      |
| Actuator - Motorised leadscrew linear slide  | 2-28 to 2-29      |
| Actuator - ScrewRail® assembly               | 7-40 to 7-41      |
| Actuator - Solid round rack                  | 2-16 to 2-17      |
| Actuator - Tubular rack                      | 2-15              |
| Anti-backlash clamp hub gears                | 4-22 to 4-34      |
| Anti-backlash clamp hub pinions              | 4-12 to 4-20      |
| Anti-backlash gears                          | 4-22 to 4-35      |
| Anti-backlash leadscrews                     | 7-4               |
| Anti-backlash pin hub gears                  | 4-23 to 4-35      |
| Anti-backlash pin hub pinions                | 4-13 to 4-21      |
| Anti-backlash pinions                        | 4-12 to 4-21      |
| Anti-backlash pinions - miniature            | 4-7 to 4-11       |
| Anti-backlash rack pinions                   | 6-11              |
| Anti-backlash ScrewRail® actuator assembly   | 7-42 to 7-43      |
| <b>B</b>                                     |                   |
| Ball & crossed roller slides                 | 9-14 to 9-15      |
| Ball bearings - P4                           | 12-2              |
| Ballslides - Rack driven                     | 9-16 to 9-17      |
| Bearings - Ball                              | 12-2              |
| Bearings - Bronze                            | 12-3              |
| Bearings - Moulded                           | 12-4              |
| Bearings - Pre-loaded washers                | 12-5              |
| Bearings - Spacers                           | 12-6 to 12-7      |
| Bellows couplings                            | 8-18 to 8-23      |
| Belts - Timing                               | 10-2, 10-4        |
| Bevel gearboxes                              | 3-14 to 3-23      |
| Bevel gears                                  | 5-8 to 5-10, 5-13 |
| Bronze bearings                              | 12-3              |
| <b>C</b>                                     |                   |
| Captive screws                               | 13-4              |
| Cheese head machine screws                   | 13-10             |
| Circlips - External                          | 13-20             |
| Circlips - Internal                          | 13-21             |
| Clamp cleats                                 | 13-14             |
| Clamp collars                                | 8-53              |
| Clamp collars - Double width                 | 8-52              |

See Pages A-7 to A-9 for Part Number Index



| Product                                   | Page         |
|---|--------------|
| Clamp collars - One piece set screw       | 8-55         |
| Clamp collars - One piece threaded        | 8-54         |
| Clamps - Gear                             | 11-4 to 11-5 |
| Coiled pins                               | 13-18        |
| Countersunk machine screws                | 13-8         |
| Couplings - Bellows                       | 8-18 to 8-23 |
| Couplings - Curved jaw                    | 8-36 to 8-37 |
| Couplings - Flexible disc spring          | 8-24 to 8-29 |
| Couplings - Friction clutches             | 8-47 to 8-50 |
| Couplings - Membrane                      | 8-32 to 8-35 |
| Couplings - Oldham                        | 8-30 to 8-31 |
| Couplings - Radial tooth                  | 8-46         |
| Couplings - Reli-a-Flex® custom designs   | 8-16         |
| Couplings - Reli-a-Flex® micro            | 8-8 to 8-9   |
| Couplings - Reli-a-Flex® precision        | 8-10 to 8-17 |
| Couplings - Selection guide               | 8-2 to 8-5   |
| Couplings - Solid                         | 8-51         |
| Couplings - Spiral beam                   | 8-38 to 8-45 |
| Couplings - Spiral beam micro             | 8-38         |
| Couplings - Spiral beam stainless steel   | 8-44         |
| Couplings - Technical information         | T8-1 to T8-4 |
| Cup point set screws                      | 13-11        |
| Curved jaw couplings                      | 8-36 to 8-37 |
| <b>D</b>                                  |              |
| Disc springs                              | 13-15        |
| Dowel pins                                | 13-19        |
| <b>E</b>                                  |              |
| External circlips                         | 13-20        |
| Epicyclic gearbox modules                 | 3-24 to 3-27 |
| <b>F</b>                                  |              |
| Flexible disc spring couplings            | 8-24 to 8-29 |
| Friction clutches                         | 8-47 to 8-50 |
| <b>G</b>                                  |              |
| Gear clamps                               | 11-4 to 11-5 |
| Gear clamp hubs                           | 11-7         |
| Gear pin hubs                             | 11-6         |
| Gearboxes - Bevel                         | 3-14 to 3-23 |
| Gearboxes - Custom                        | 3-28 to 3-31 |
| Gearboxes - Hypoid                        | 3-16         |
| Gearboxes - Epicyclic modules             | 3-24 to 3-27 |
| Gearboxes - Planetary                     | 3-3 to 3-13  |
| Gears - Anti-backlash (pin and clamp hub) | 4-22 to 4-35 |

See Pages A-7 to A-9 for Part Number Index



| Product                                   | Page              |
|---|-------------------|
| Gears - Bevel                             | 5-8 to 5-10, 5-13 |
| Gears - Brass bevel                       | 5-14              |
| Gears - Brass hubless                     | 4-78 to 4-81      |
| Gears - Brass spur                        | 4-70 to 4-77      |
| Gears - Clamp hub spur                    | 4-36 to 4-50      |
| Gears - Ground spur                       | 4-60 to 4-69      |
| Gears - Hardened spur                     | 4-56 to 4-59      |
| Gears - Hubless spur                      | 4-52 to 4-55      |
| Gears - Internal (brass spur)             | 5-15              |
| Gears - Keys and keyways for ground gears | 4-69              |
| Gears - Mitre bevel                       | 5-11 to 5-12      |
| Gears - Part numbering                    | 4-6               |
| Gears - Pin hub spur                      | 4-37 to 4-51      |
| Gears - Pinions (miniature)               | 4-7 to 4-11       |
| Gears - Plain (pin and clamp hub)         | 4-36 to 4-51      |
| Gears - Technical information             | T4-1 to T4-18     |
| Gears - Worms and wheels                  | 5-2 to 5-7        |
| Guides - Miniature linear                 | 9-7 to 9-11       |
| <b>H</b>                                  |                   |
| Hubless spur gear                         | 4-52 to 4-55      |
| Hypoid gearboxes                          | 3-16              |
| <b>I</b>                                  |                   |
| Internal circlips                         | 13-21             |
| <b>L</b>                                  |                   |
| Leadscrew linear slide                    | 7-38 to 7-39      |
| Leadscrew linear slide - Motorised        | 2-28 to 2-29      |
| Leadscrews - Anti-backlash nuts           | 7-16 7-25         |
| Leadscrews - Available sizes              | 7-7 to 7-11       |
| Leadscrews - Custom nut configurations    | 7-26              |
| Leadscrews - End modifications            | 7-27 to 7-35      |
| Leadscrews - Miniature anti-backlash nuts | 7-15              |
| Leadscrews - Miniature plain nuts         | 7-12              |
| Leadscrews - Nut comparison chart         | 7-5               |
| Leadscrews - Nut styles                   | 7-4               |
| Leadscrews - Plain nuts, general purpose  | 7-13 to 7-14      |
| Leadscrews - Technical information        | T7-1 to T7-5      |
| Linear actuator - Hybrid/Can-Stack        | 2-24 to 2-25      |
| Linear guides                             | 9-7 to 9-11       |
| Linear rail actuator                      | 2-26 to 2-27      |
| Linear rails                              | 9-6               |
| Linear slide - Leadscrew                  | 7-38 to 7-39      |
| Linear slide - Motorised                  | 2-19 to 2-23      |

See Pages A-7 to A-9 for Part Number Index



| Product   |  | Page         |
|---|--|--------------|
| <b>M</b>  |  |              |
| Machine screws - Cheese head                        |  | 13-10        |
| Machine screws - Countersunk head                   |  | 13-8         |
| Machine screws - Pan head                           |  | 13-9         |
| Membrane couplings                                  |  | 8-32 to 8-35 |
| Miniature linear guides                             |  | 9-7 to 9-11  |
| Miniature stroke slides                             |  | 9-12 to 9-13 |
| Motor - Reliance Cool Muscle                        |  | 2-2 to 2-13  |
| Motorised actuators                                 |  | 2-14 to 2-29 |
| Moulded bearings                                    |  | 12-4         |
| <b>N</b>  |  |              |
| Nut styles - Leadscrews                             |  | 7-4          |
| Nuts  |  | 13-16        |
| Nylon tip set screws                                |  | 13-13        |
| <b>O</b>  |  |              |
| Oldham couplings                                    |  | 8-30 to 8-31 |
| <b>P</b>  |  |              |
| Pan head machine screws                             |  | 13-9         |
| Part numbering reference for gears                  |  | 4-6          |
| Part numbering reference for leadscrews             |  | 7-3          |
| Pinions - Anti-backlash                             |  | 4-12 to 4-21 |
| Pinions - Anti-backlash miniature                   |  | 4-7 to 4-11  |
| Pins - Coiled                                       |  | 13-18        |
| Pins - Dowel  |  | 13-19        |
| Planetary gearboxes                                 |  | 3-3 to 3-13  |
| Plain socket head screws                            |  | 13-2         |
| Precision couplings                                 |  | 8-10 to 8-17 |
| Pre-loaded washers                                  |  | 12-5         |
| Product overview - Bespoke motorised actuators      |  | 2-18         |
| Product overview - Bevel gearboxes                  |  | 3-14         |
| Product overview - Brass gears                      |  | 4-70         |
| Product overview - Couplings and collars            |  | 8-2 to 8-7   |
| Product overview - Custom gearboxes                 |  | 3-28         |
| Product overview - Epicyclic gearboxes              |  | 3-24         |
| Product overview - Ground spur gears                |  | 4-60         |
| Product overview - Hybrid linear actuators          |  | 2-24         |
| Product overview - Leadscrew and nut assemblies     |  | 7-2 to 7-6   |
| Product overview - Leadscrew assemblies             |  | 7-36         |
| Product overview - Linear guides and slides         |  | 9-2          |
| Product overview - Linear rail actuator             |  | 2-26         |
| Product overview - Motorised leadscrew linear slide |  | 2-28         |
| Product overview - Planetary gearboxes              |  | 3-3          |
| Product overview - Precision gears                  |  | 4-2 to 4-5   |

**See Pages A-7 to A-9 for Part Number Index**



| Product                                       | Page       |
|---|------------|
| Product overview - Racks and pinions          | 6-2        |
| Product overview - Reliance cool muscle       | 2-2        |
| Product overview - Reliance cool muscle stage | 2-19       |
| Product overview - Rack actuators             | 2-14       |
| Product overview - Worms and wheels           | 5-2        |
| Pulleys - Timing                              | 10-3, 10-5 |

## R

|   |              |
|---|--------------|
| Rack - Brass                                    | 6-9          |
| Rack - Hardened round                           | 6-4          |
| Rack - Rectangular                              | 6-3, 6-8     |
| Rack - Round                                    | 6-4 to 6-7   |
| Rack - Tubular                                  | 6-6          |
| Rack driven actuator                            | 2-14 to 2-17 |
| Rack driven ball slides                         | 9-16 to 9-17 |
| Rack pinions                                    | 6-10 to 6-11 |
| Racktuator™ - Solid round rack                  | 2-16 to 2-17 |
| Racktuator™ - Tubular rack                      | 2-15         |
| Radial tooth couplings                          | 8-46         |
| Reli-a-Flex® couplings                          | 8-6 to 8-17  |
| Reli-a-Grip™ clamp - Couplings                  | 8-14 to 8-15 |
| Reliance Cool Muscle stage - Leadscrew actuator | 2-19 to 2-23 |
| Reliance Cool Muscle motor                      | 2-2 to 2-13  |
| Reliance Cool Muscle motor cables               | 2-10 to 2-11 |

## S

|  |              |
|--|--------------|
| ScrewRail® actuator assembly                 | 7-40 to 7-41 |
| ScrewRail® actuator assembly - Anti-backlash | 7-42 to 7-43 |
| Screws - Captive                             | 13-4         |
| Screws - Cheese head machine                 | 13-10        |
| Screws - Countersunk head machine            | 13-8         |
| Screws - Pan head machine                    | 13-9         |
| Screws - Plain socket                        | 13-2         |
| Screws - Shoulder                            | 13-6 to 13-7 |
| Screws - Ventilation                         | 13-5         |
| Screws - Wire locking                        | 13-3         |
| Servo system - Reliance cool muscle          | 2-2 to 2-13  |
| Set screws - Cup point                       | 13-11        |
| Set screws - Nylon tip                       | 13-13        |
| Set screws - Solder tip                      | 13-12        |
| Shaft end modifications                      | 7-27 to 7-35 |
| Shafts - Ground stock                        | 11-2         |
| Shafts - Retaining collars                   | 11-3         |
| Shoulder screws                              | 13-6 to 13-7 |
| Slides - Ball                                | 9-14 to 9-15 |
| Slides - Crossed roller                      | 9-14 to 9-15 |
| Slides - Miniature stroke                    | 9-12 to 9-13 |

See Pages A-7 to A-9 for Part Number Index





| Product                       | Page         |
|-------------------------------|--------------|
| Slides - Rack driven          | 9-16 to 9-17 |
| Solder tip set screws         | 13-12        |
| Solid couplings               | 8-51         |
| Spacers - Bearings            | 12-6 to 12-7 |
| Spiral beam couplings         | 8-38 to 8-45 |
| Spiral beam couplings - Micro | 8-38         |
| Spline shafts                 | 9-4 to 9-5   |

## T

|  |                |
|--|----------------|
| Technical information                                      | T0 to T13-2    |
| Technical information - Bearing force sharing              | T12-3          |
| Technical information - Bearing gear mesh reactions        | T12-1          |
| Technical information - Bearing installation               | T12-4          |
| Technical information - Bearing life                       | T12-3          |
| Technical information - Bearing specification              | T12-1          |
| Technical information - Belts and pulley engineering data  | T10-1 to T10-2 |
| Technical information - Belts and pulleys                  | T10-1 to T10-2 |
| Technical information - Belts and pulleys introduction     | T10-1          |
| Technical information - Conversion factors                 | T-2            |
| Technical information - Coupling installation              | T8-3           |
| Technical information - Coupling transmission error        | T8-2           |
| Technical information - Couplings                          | T8-1 to T8-4   |
| Technical information - Epicyclic gearbox modules          | T3-4 to T3-6   |
| Technical information - Gear backlash                      | T4-17          |
| Technical information - Gear engineering data              | T4-9 to T4-16  |
| Technical information - Gear geometry                      | T4-5           |
| Technical information - Gear materials and specifications  | T4-4           |
| Technical information - Gear terminology                   | T4-6 to T4-7   |
| Technical information - Gear tolerances                    | T4-1           |
| Technical information - Gears with small number of teeth   | T4-8           |
| Technical information - Hardware ISO metric screw threads  | T13-1          |
| Technical information - Hardware torque and tension guides | T13-1          |
| Technical information - Leadscrew engineering data         | T7-2 to T7-5   |
| Technical information - Leadscrew features                 | T7-1           |
| Technical information - Leadscrew TFE coated assemblies    | T7-5           |
| Technical information - Leadscrews                         | T7-1 to T7-5   |
| Technical information - Linear slides                      | T9-1 to T9-4   |
| Technical information - Linear slide engineering data      | T9-1           |
| Technical information - Linear slide features              | T9-1           |
| Technical information - Miniature linear guides            | T9-3           |
| Technical information - Miniature stroke slides            | T9-2           |
| Technical information - Planetary gearboxes                | T3-1 to T3-3   |
| Technical information - Rack applications                  | T6-6           |
| Technical information - Rack engineering data              | T6-2 to T6-4   |
| Technical information - Rack installation                  | T6-4 to T6-6   |
| Technical information - Rack manufacture                   | T6-1           |
| Technical information - Rack standards and tolerances      | T6-1           |

See Pages A-7 to A-9 for Part Number Index



|  |          |              |
|--|----------|--------------|
| Technical information - Racks and pinions                      |          | T6-1 to T6-6 |
| Technical information - Ractuato <sup>TM</sup>                 |          | T2-9         |
| Technical information - Racktuato <sup>TM</sup> stepper motors |          | T2-10        |
| Technical information - Racktuato <sup>TM</sup> installation   |          | T2-9         |
| Technical information - Reliance Cool Muscle                   |          | T2-1 to T2-8 |
| Technical information - Worms and wheels formulae              |          | T4-19        |
| Timing belts   |          | 10-2, 10-4   |
| Timing pulleys   |          | 10-3, 10-5   |
| Tubular rack actuator  |          | 2-15         |
|  | <b>V</b> |              |
| Ventilation screws   |          | 13-5         |
|  | <b>W</b> |              |
| Washers  |          | 13-17        |
| Washers - Bearing pre-loaded                                   |          | 12-5         |
| Wire locking screws  |          | 13-3         |
| Worms and wheels   |          | 5-2 to 5-7   |

See Pages A-7 to A-9 for Part Number Index

|   |   |           |
|---|---|-----------|
|   | <i>Introduction to Reliance</i>                       | <i>i</i>  |
|   | <i>Systems Overview</i>                               | <i>1</i>  |
|    | <b>Intelligent Motors and Motorised Actuators</b>     | <b>2</b>  |
|    | <b>Planetary and Right Angle Gearboxes</b>            | <b>3</b>  |
|    | <b>Brass, Ground and Precision Spur Gears</b>         | <b>4</b>  |
|    | <b>Worms and Wheels, Bevels and Internal Gears</b>    | <b>5</b>  |
|    | <b>Round and Rectangular Racks and Pinions</b>        | <b>6</b>  |
|    | <b>Leadscrews and Leadscrew Assemblies</b>            | <b>7</b>  |
|    | <b>Flexible Shaft Couplings, Clutches and Collars</b> | <b>8</b>  |
|    | <b>Linear Guides and Slides</b>                       | <b>9</b>  |
|   | <b>Belts and Pulleys</b>                              | <b>10</b> |
|  | <b>Gear Clamps and Accessories</b>                    | <b>11</b> |
|  | <b>Bearings and Spacers</b>                           | <b>12</b> |
|  | <b>Machine Screws, Dowel Pins and Hardware</b>        | <b>13</b> |
|   | <i>Technical Information</i>                          | <i>14</i> |
|   | <i>Appendices and Index</i>                           | <i>15</i> |

|  |    |
|--|----|
| Systems Overview                               | 1  |
| Intelligent Motors and Motorised Actuators     | 2  |
| Planetary and Right Angle Gearboxes            | 3  |
| Brass, Ground and Precision Spur Gears         | 4  |
| Worms and Wheels, Bevels and Internal Gears    | 5  |
| Round and Rectangular Racks and Pinions        | 6  |
| Leadscrews and Leadscrew Assemblies            | 7  |
| Flexible Shaft Couplings, Clutches and Collars | 8  |
| Linear Guides and Slides                       | 9  |
| Belts and Pulleys                              | 10 |
| Gear Clamps and Accessories                    | 11 |
| Bearings and Spacers                           | 12 |
| Machine Screws, Dowel Pins and Hardware        | 13 |
| Technical Information                          | 14 |



Rowley Mills, Penistone Road, Lepton  
Huddersfield, HD8 0LE, England

+44 (0) 1484 601002

[www.reliance.co.uk](http://www.reliance.co.uk)

[sales@reliance.co.uk](mailto:sales@reliance.co.uk)

RG36 Issue A2