

Z- θ Actuator

Operating Instruction

 **KSS** **co.,LTD.**
www.kss-superdrive.co.jp

本社

〒146-0093 東京都大田区矢口1-22-14
TEL.03-3756-3921 FAX.03-3756-3232

小千谷出張所

〒947-0043 新潟県小千谷市大字山谷字新保4-14
TEL.0258-89-6257 FAX.0258-81-1339

Head Office

1-22-14 Yaguchi, Ohta-ku, Tokyo 146-0093, Japan
Tel :+81-3-3756-3921 Fax :+81-3-3756-3232

Contents

§1 Actuator Installation	3
§2 Regarding Shaft free-fall.....	5
§3 Procedure of home position	6
§4 Connection Diagram	7
§5 Operating Precautions	9
§6 Safety Precautions, Operating Environment	10

1 Actuator Installation

There are 2 ways to install Z-θ Actuator to the device. Please refer to the illustration below to suit its mounting position for your device.

【Direct-Drive】

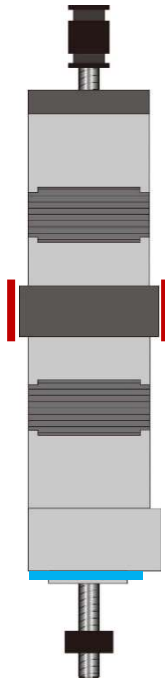

【Hybrid-Drive】

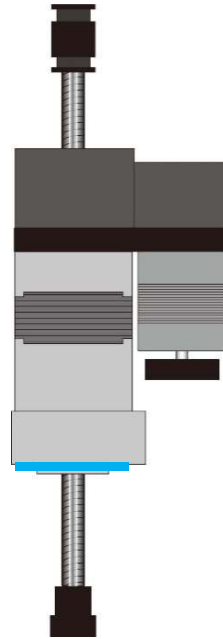

【Belt-Drive】

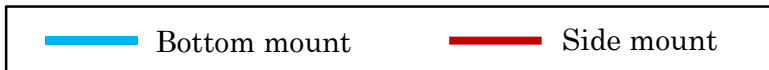
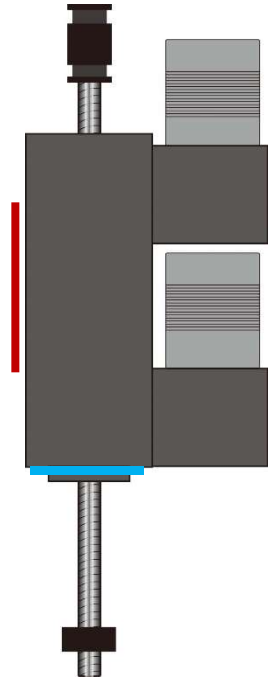

【Bottom mount】

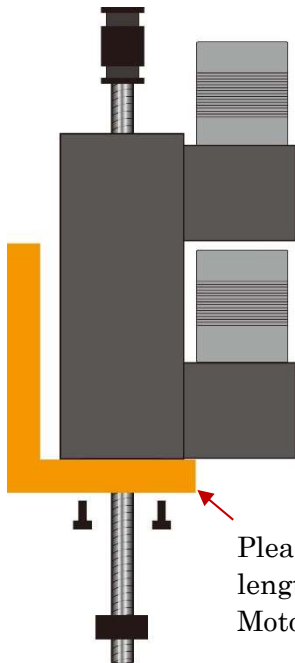

Please be aware of losing travel length due to the thickness of the Motor mounting plate.

【Side mount】

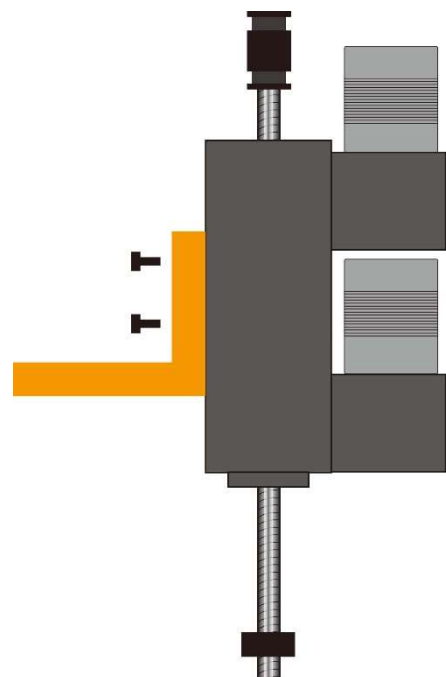

【Actuator mounting posture】

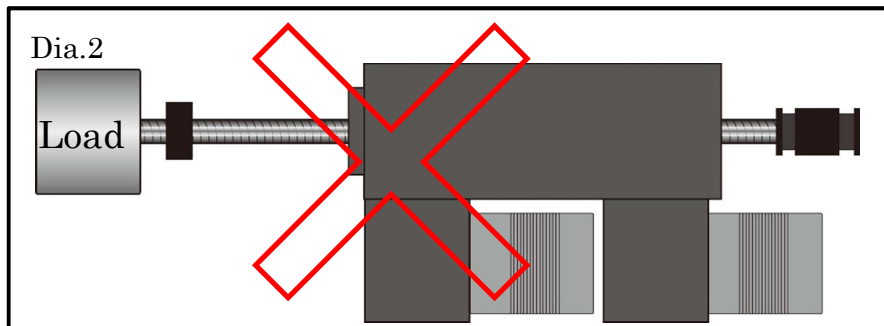
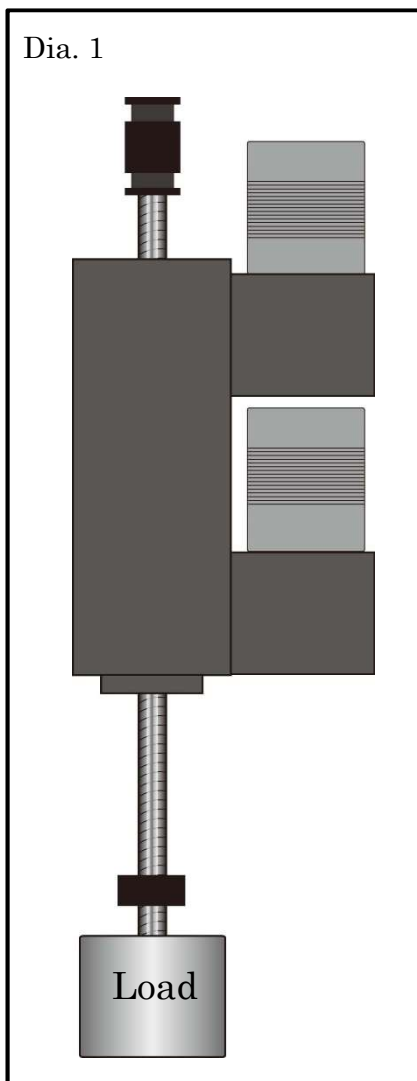

- Radial load cannot be applied on Z- θ Actuator. Please use it in vertical position, as illustrated on [Dia. 1] above.
- Do not apply load as [Dia. 2]. Radial load will directly apply to Ball Screw and may damage recirculation part of Ball Screw mechanism.

*Illustration used Belt-Drive type as example. Please refer to the example and use the same posture as for Direct-Drive type and Hybrid-Drive type.

2 Regarding Shaft free-fall

Z-θ Actuator does not equip with anti-free-fall device. Therefore, if free falling is not allowed at power off, external anti-free fall device should be set up on your own.

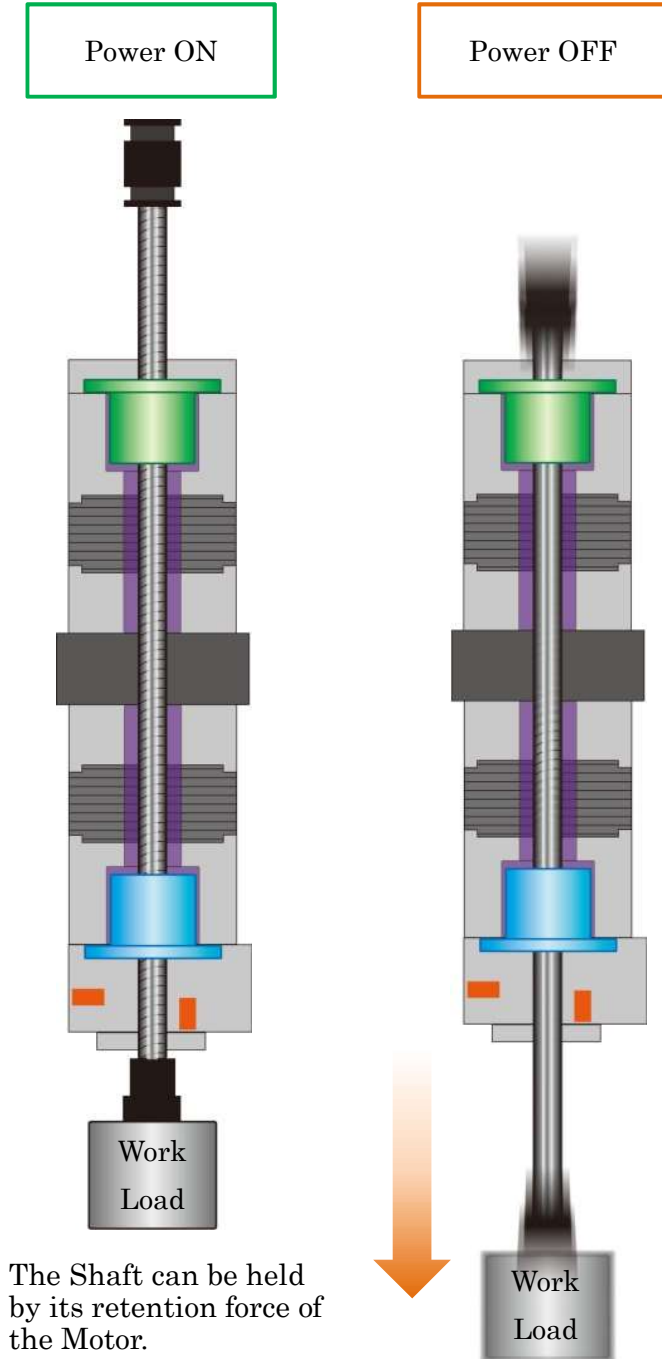

The Shaft can be held by its retention force of the Motor.

The Shaft will free fall at the power off, by the loss of retention force from the Motor.

For your reference, below tables shows the free fall load for each type of Actuator.

		Free-Falling Load
Direct Drive	□28	7N (Lead 6mm)
		2N (Lead 10mm)
	□42	18N (Lead 5mm)
		5N (Lead 10mm)
Hybrid Drive	—	3N
Belt Drive (※1)	04	18N
	06	17N
	08	16N

Caution: Values are not guaranteed. Please take them as reference value.

※1) Please ask KSS if pulley ratio is other than 1:2.

3 Procedure of home positioning

In order to apply home positioning, we recommend that θ -axis should be the first, then followed by Z-axis. If Z-axis home positioning is first, then zero position may move after θ -axis home positioning.

[Recommended procedure of home positioning]

$\theta \Rightarrow Z$ axis

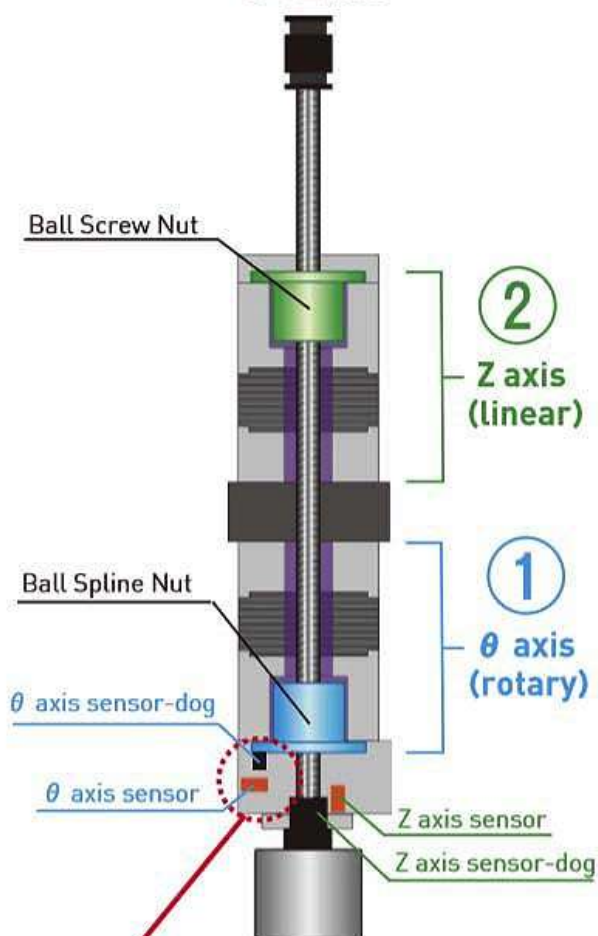

θ -axis home positioning has been done in zero position. In this situation, Z-axis home positioning should be applied. θ -axis will never move because Ball Spline Nut only plays a role of guide for linear motion.

[In case of home positioning]

Z \Rightarrow θ axis

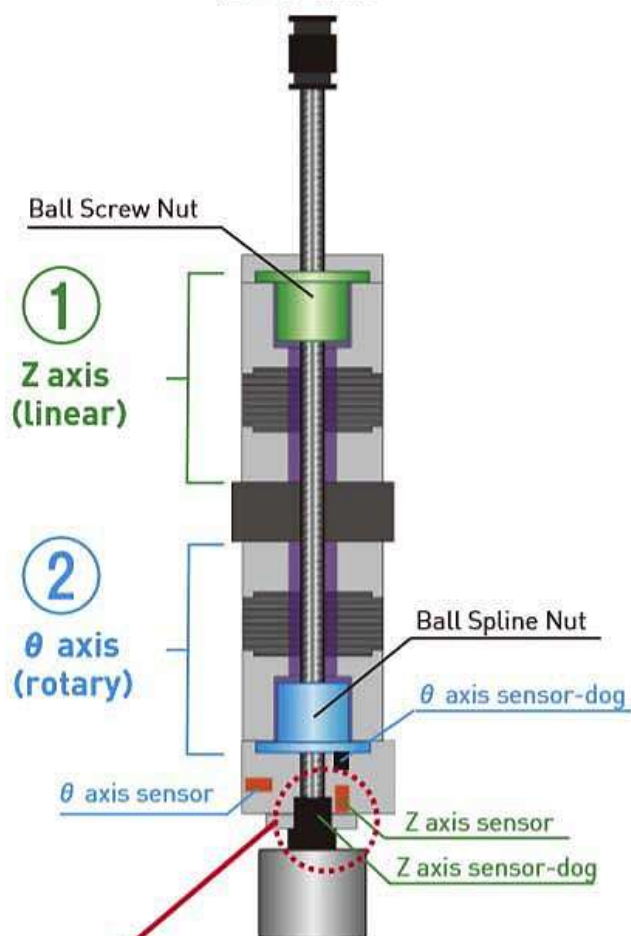

Z-axis home positioning has been done in zero position. In this situation, if θ -axis home positioning is applied, BSSP Shaft (Ball Screw with Ball Spline) will move up or down with rotary movement at the same time of CW/CCW home positioning.

*Illustration used Belt-Drive type as example. Please refer to the example and use the same procedure as for Direct-Drive type and Hybrid-Drive type.

4 Connection Diagram

【□28ダイレクトドライブ型 / □28 Direct Drive type】

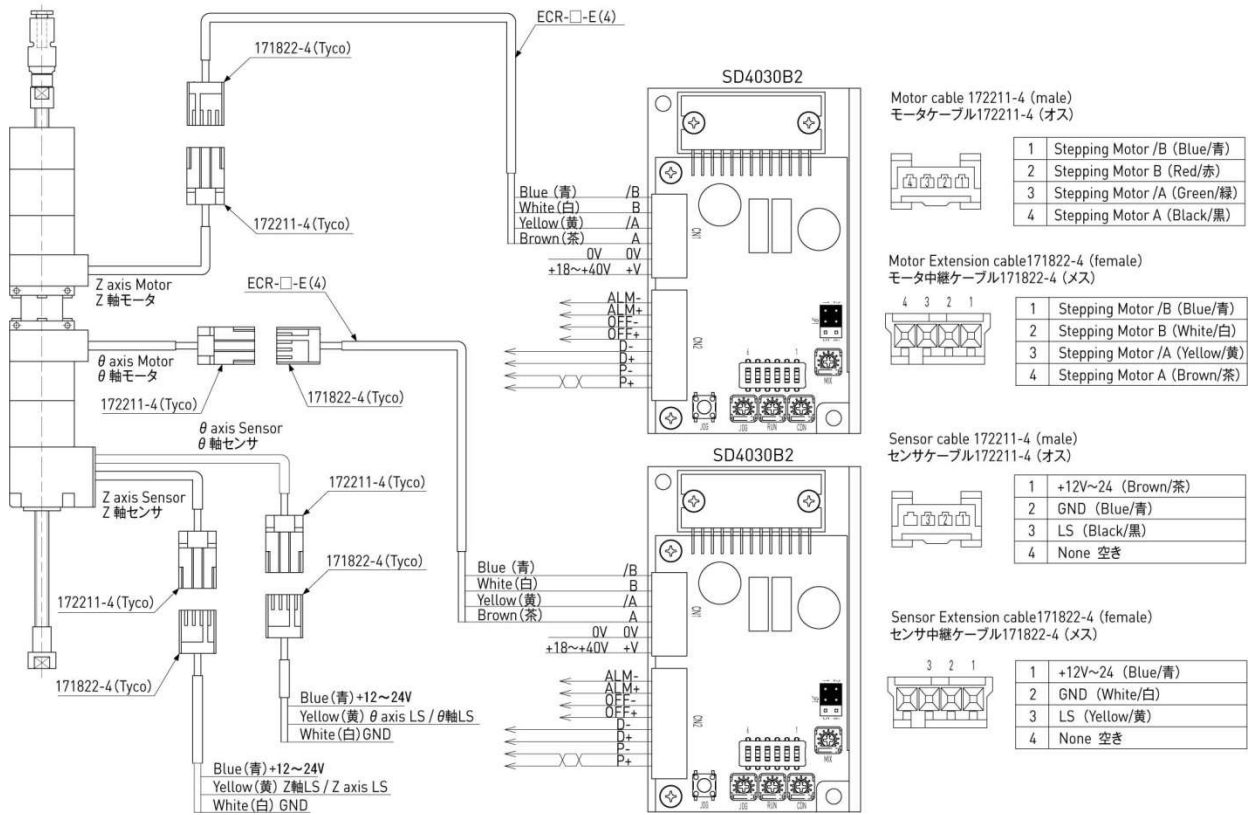

【□42ダイレクトドライブ型 / □42 Direct Drive type】

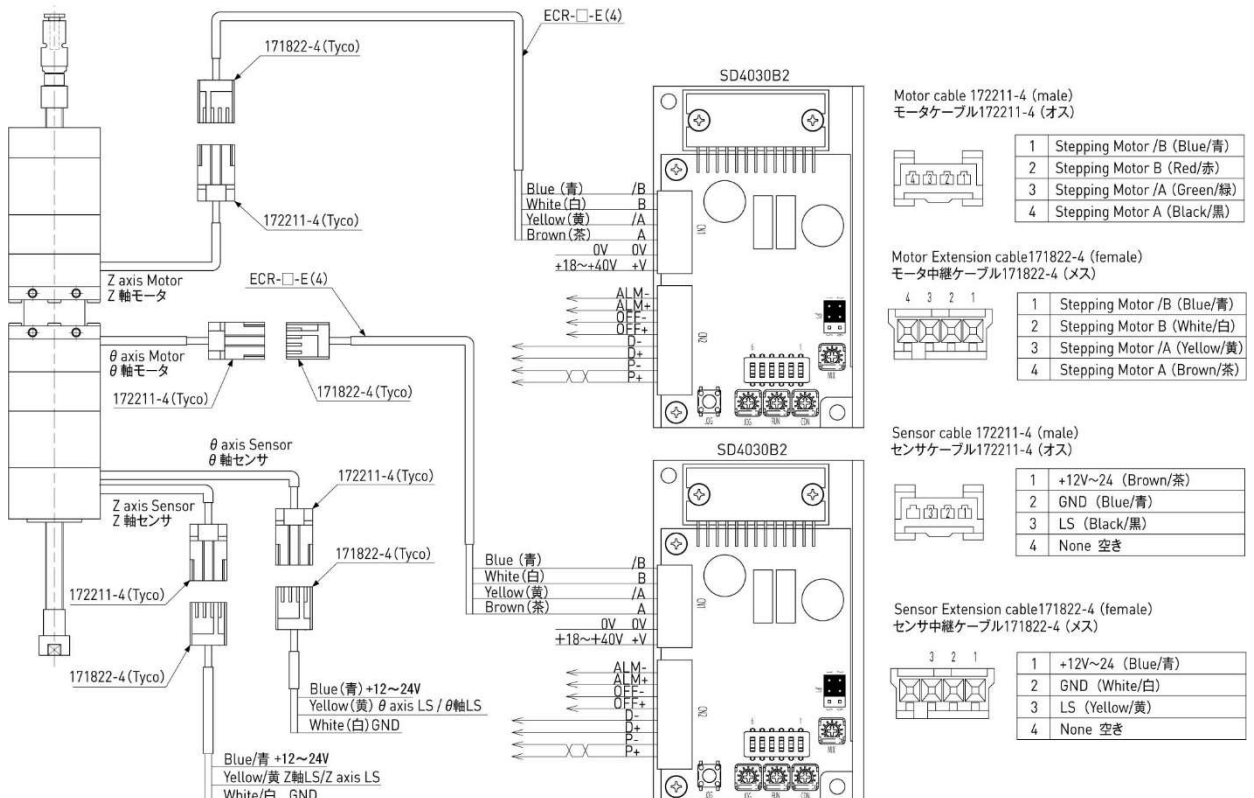

【ハイブリッドドライブ型 / Hybrid Drive type】

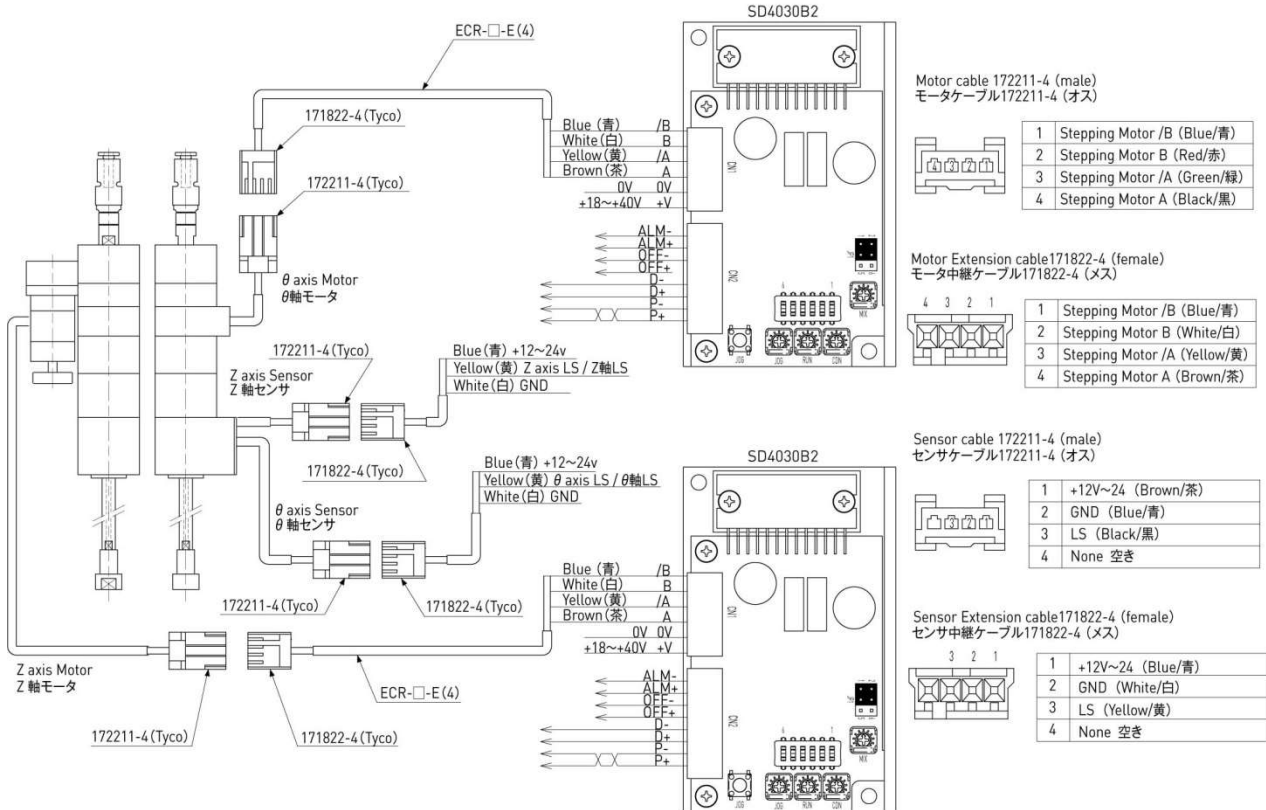

【ベルトドライブ型 / Belt Drive type】

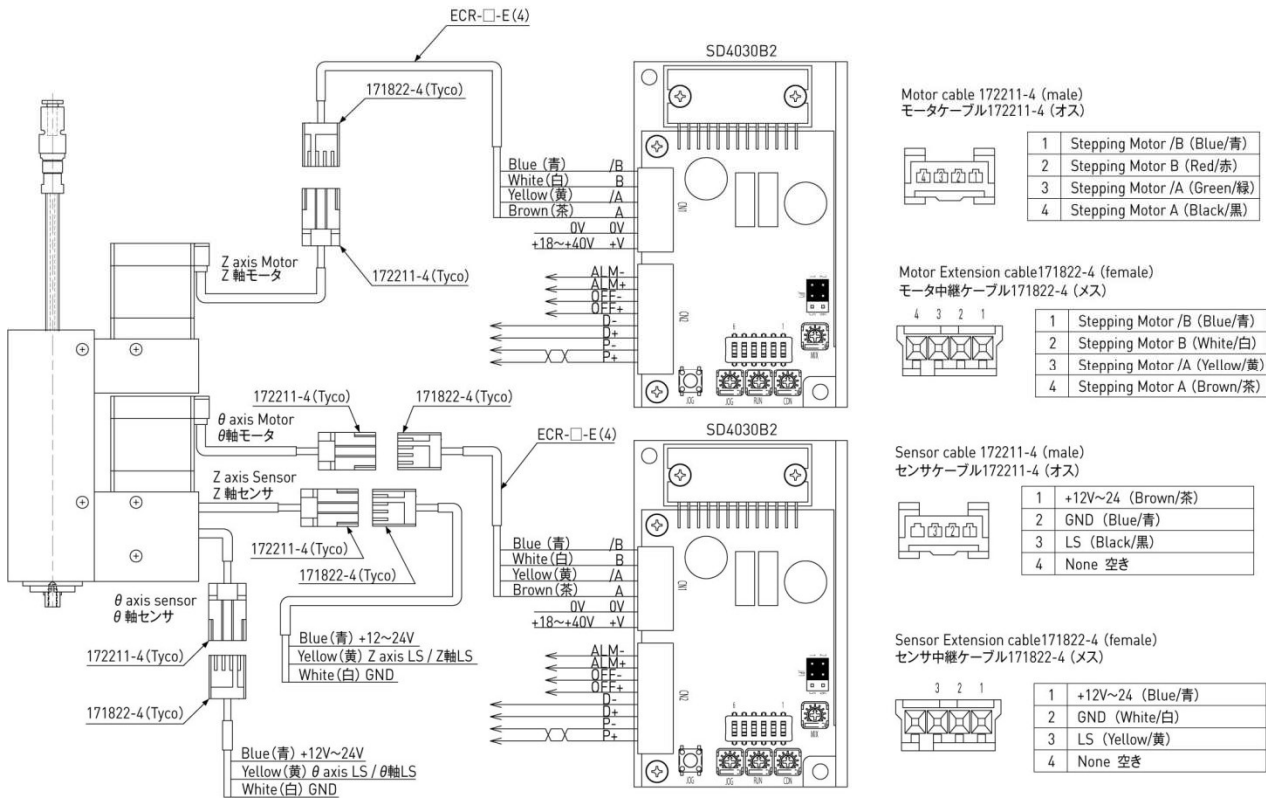

5 Operating Precautions

- 1) Before using these products, please read instruction manuals and follow the precautions below.
- 2) Do not hit or drop the Shaft, do not apply Radial or Axial load exceeding specifications, it may cause malfunction.
- 3) Before using, please check that the product has no defect, and product is the same as your order.
- 4) Do not disassemble the component, dust may get inside the product. It may deteriorate accuracy.
- 5) Please prevent from contamination such as dust or swarf. Dust or swarf may cause damage to Ball Screw, which lead to deteriorating the function.
- 6) Motor is not designed to resist water or oil. It cannot be used in direct exposure of water or oil, or environment such as oil bath.
- 7) Lubrication is required under the Ball Screw operation at any time.
Lubrication condition should be checked in every 2 to 3 months with regular basis. If Grease is contaminated, remove old Grease and replace with new one.
- 8) Do not use the Actuator exceeding our specification in Load or Speed.
- 9) Care must be taken not to apply Radial load or Moment load directly on Ball Screw. This will lead to shorten the Ball Screw life remarkably. In addition, misalignment between Ball Screw and other components will lead to deterioration of function, such as accuracy, life and so on.
- 10) Allowing Ball Screw Nut to over-run may result in malfunctioning due to Ball escaping, damage to recirculation parts, and dents on the raceways. Continued use in this state will lead to rapid wear and damage to recirculation parts. Therefore Ball Screw Nut must never be allowed to over-run. If over-run occurs, contact KSS for an inspection with charge.
- 11) Do not hold Motor wires. Motor lead wire is for fixation, do not use the Motor lead wire as movable part.
- 12) Keep away from Magnetic memory device.
- 13) The Motor has a resonant point within the specifications. Please avoid the resonant point when in use.

6 Safety Precautions

- 1) If abnormal odor, noise, smoke, overheating or vibration occurs, stop operation immediately and turn the power off.
- 2) Check and confirm the polarity of the power supply in prior to activate the Motor.
- 3) The Motor may overheat depending on the load condition or Driver used. Make sure that the Motor surface temperature does not exceed 80 degrees (Celsius) when in use.
- 4) Check the wire connection type, Drive systems and phase sequence. Inappropriate connection leads to malfunction.
- 5) A ground connection must be used.
- 6) Do not bend, pull or pinch the Motor lead wire.
- 7) Do not touch moving parts during operation.
- 8) Please switch off the Driver, when inspection or maintenance.

Operating Environment

- 1) Operating environment should be 0~40 degrees (Celsius) in temperature and 20~80%RH in humidity. Do not use the Actuator under dew condensation, corrosive gas or inflammable gas environment.
- 2) Do not use the Actuator under strong electric field and strong magnetic field.
- 3) Please prevent from swarf, oil mist, cutting fluid, water / moisture, salt spray, organic solvent and other contamination.
- 4) The Actuator cannot be used under the vibration, impact, vacuum and other special environment.